

VIVOIL

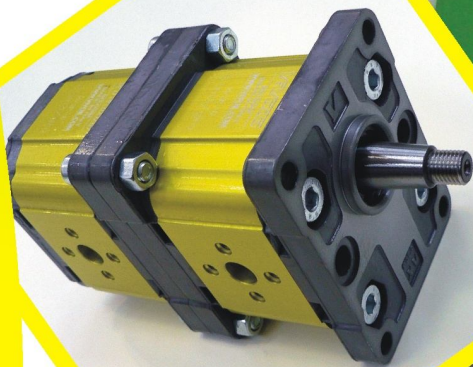

ENGLISH

Multiple Pumps

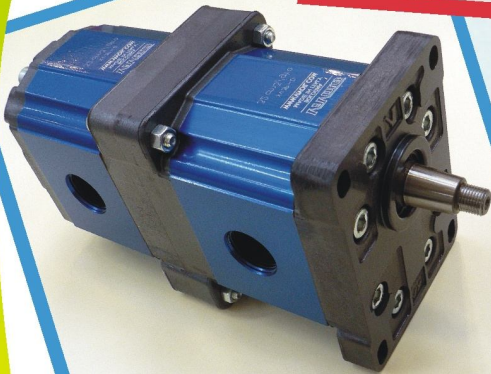
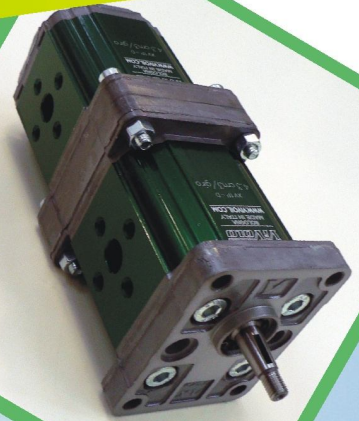
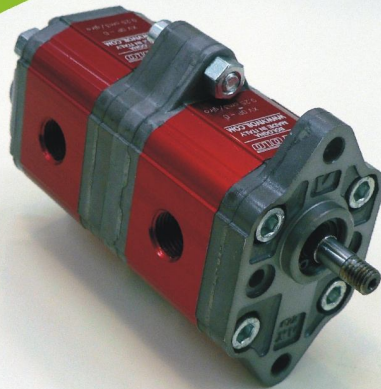
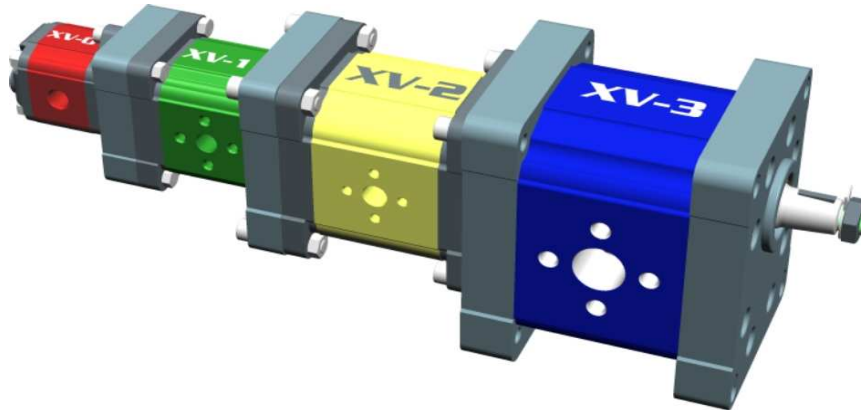

XV-0P	Unidirectional Pump	
XV-1P	Left Rotation	Right Rotation
XV-2P		
XV-3P		

XV-0U	Unidirectional Motor	
XV-1U	Left Rotation	Right Rotation
XV-2U		
XV-3U		

XV-0R	Reversible Pump	
XV-1R	External drainage	Internal drainage
XV-2R		
XV-3R		

XV-0M	Reversible Motor	
XV-1M	External drainage	Internal drainage
XV-2M		
XV-3M		

XV-0T	XV-1T	XV-2T	XV-3T	Primary element of multiple pump
XV-0I	XV-1I	XV-2I	XV-3I	Intermediate element of multiple pump
XV-0F	XV-1F	XV-2F	XV-3F	Final element of multiple pump

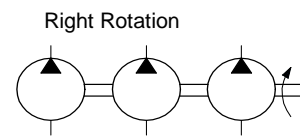
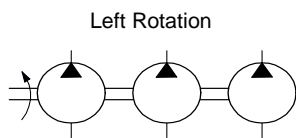

KV-DF	Flow divider
--------------	---------------------

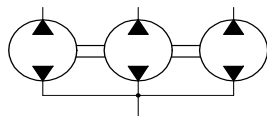

KV-DFV	Flow divided with valves
---------------	---------------------------------

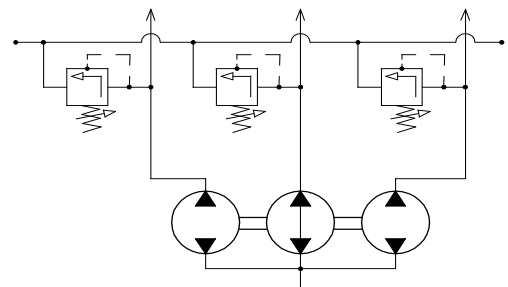

KV-DF+M	Flow divider with motor
----------------	--------------------------------

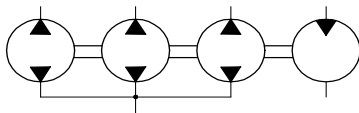

MULTIPLE PUMPS – SINGLE ELEMENTS

MULTIPLE PUMPS CATALOGUE - Introduction

The catalogue is mainly composed in two sections, reflecting the possible supply manners:

- Single elements
Dimensions, characteristics and codification of the single elements composing the multiple pumps
- Assembled pumps
Dimensions, characteristics and codes of assembled pumps

The variety of variants allows a high number of possible alternatives. Both the sections try to give an instrument to consult easily to create the ideal solution.

ASSEMBLED PUMPS

In the following section it's represented how to compose the assembled multiple pumps. For each driving pump, identified by the connection flange, two or more pages are prepared as showed in the image below. In particular you may find:

1. Three-dimensional representation of the assembled pump typology
2. Different coupling solutions
3. Special solutions
4. Dimensional and features summary table.
5. Product Code structure and corresponding **purchasing code** starting from the specific features that can be chosen from the possible solution
6. Displacement for the primary pump.

POMPA MULTIPLA XV-1
BASE ø 30

1

2

3

TIPO	Cilindrata	A	A1	B	B1	C	C1	P1	P2	Regime Max	Regime Max
	cm ³ /giro	mm	mm	mm	mm	mm	mm	bar	bar	g/min	g/min
XV1/1.0	0.91	74.5	37.5	74.5	37.5	75	37.5	240	200	700	5000
XV1/1.5	1.37	75.5	37.5	75.5	37.5	75	37.5	250	200	700	5000
XV1/2.0	1.86	77	38.5	77	38.5	80.5	38.5	250	200	700	5000
XV1/2.5	2.36	79	39.5	79	39.5	81.5	39.5	250	200	700	5000
XV1/3.0	2.86	81	40.5	81	40.5	82.5	40.5	250	200	700	5000
XV1/3.5	3.37	83	41.5	83	41.5	83	41.5	250	200	700	5000
XV1/4.0	3.88	85	42.5	85	42.5	84.5	42.5	250	200	700	5000
XV1/4.5	4.39	87	43.5	87	43.5	85.5	43.5	250	200	700	5000
XV1/5.0	4.91	89	44.5	89	44.5	86.5	44.5	250	200	700	5000
XV1/5.5	5.43	91	45.5	91	45.5	87.5	45.5	250	200	700	5000
XV1/6.0	5.95	93	46.5	93	46.5	88.5	46.5	250	200	700	5000
XV1/6.5	6.47	95	47.5	95	47.5	89.5	47.5	250	200	700	5000
XV1/7.0	7.00	97	48.5	97	48.5	90.5	48.5	250	200	700	5000
XV1/7.5	7.53	99	49.5	99	49.5	91.5	49.5	250	200	700	5000
XV1/8.0	8.06	101	50.5	101	50.5	92.5	50.5	250	200	700	5000
XV1/8.5	8.60	103	51.5	103	51.5	93.5	51.5	250	200	700	5000
XV1/9.0	9.14	105	52.5	105	52.5	94.5	52.5	250	200	700	5000
XV1/9.5	9.68	107	53.5	107	53.5	95.5	53.5	250	200	700	4900

TIPO	Cilindrata	D	D1	E	E1	F	G	G1	P1	P2	Regime Max	Regime Max	
	cm ³ /giro	mm	mm	mm	mm	mm	mm	mm	bar	bar	g/min	g/min	
XV1/1.1	0.16	12.3	46.5	13.8	46.5	15.4	26.5	12.3	26.5	220	210	700	6000
XV1/1.2	0.24	12.3	46.5	16.4	46.5	18.0	26.5	12.3	26.5	220	210	700	6000
XV1/1.3	0.45	14.5	47.5	17.8	47.5	19.4	27.5	14.5	27.5	220	210	700	6000
XV1/1.5	0.56	15.5	47.5	17.8	47.5	19.4	27.5	15.5	27.5	220	210	700	6000
XV1/1.7	0.75	17.7	48.5	19.5	48.5	21.0	28.5	17.7	28.5	220	210	700	6000
XV1/1.9	0.94	18.6	48.5	19.4	48.5	20.9	28.5	18.6	28.5	220	210	700	6000
XV1/2.1	1.13	19.6	49.5	21.0	49.5	22.5	29.5	19.6	29.5	220	210	700	6000
XV1/2.3	1.32	20.6	49.5	21.0	49.5	22.5	29.5	20.6	29.5	220	210	700	6000
XV1/2.5	1.48	21.6	49.5	21.0	49.5	22.5	29.5	21.6	29.5	220	210	700	6000
XV1/2.7	1.67	22.6	49.5	21.0	49.5	22.5	29.5	22.6	29.5	220	210	700	6000

Vinci OleodinamicaVinci s.r.l. - Società a Sede Unica - via Lancia Giordano 2-4 40054Busto (BO) Italy Tel: +39051 899689 Fax: +39051 899981
www.vincicosp.com - SpA

POMPA MULTIPLA XV-1
BASE ø 32 Sagomata - TIPO "BH"

5

6

9 M 3 42 D G A 25 25 25

NUMERO DI ELEMENTI

CILINDRATA

16	XV-PP6.0	81	XV-PP6.17
17	XV-PP1.2	82	XV-PP6.25
18	XV-PP1.7	84	XV-PP6.45
20	XV-PP2.1	85	XV-PP6.67
21	XV-PP2.5	86	XV-PP6.78
23	XV-PP3.2	87	XV-PP6.88
25	XV-PP3.5	88	XV-PP1.27
27	XV-PP4.5	89	XV-PP1.52
29	XV-PP4.8	90	XV-PP1.52
31	XV-PP5.5	91	XV-PP1.52
32	XV-PP6.5	92	XV-PP1.52
34	XV-PP7.8	93	XV-PP1.52
36	XV-PP8.5	94	XV-PP1.52

COPEROCHIO

CORPO

C

G

M

A

UNF

CILINDRATA

16 XV-PP6.0 | 81 | XV-PP6.17 |

17 XV-PP1.2 | 82 | XV-PP6.25 |

18 XV-PP1.7 | 84 | XV-PP6.45 |

20 XV-PP2.1 | 85 | XV-PP6.67 |

21 XV-PP2.5 | 86 | XV-PP6.78 |

23 XV-PP3.2 | 87 | XV-PP6.88 |

25 XV-PP3.5 | 88 | XV-PP1.27 |

27 XV-PP4.5 | 89 | XV-PP1.52 |

29 XV-PP4.8 | 90 | XV-PP1.52 |

31 XV-PP5.5 | 91 | XV-PP1.52 |

32 XV-PP6.5 | 92 | XV-PP1.52 |

34 XV-PP7.8 | 93 | XV-PP1.52 |

36 XV-PP8.5 | 94 | XV-PP1.52 |

Vinci OleodinamicaVinci s.r.l. - Società a Sede Unica - via Lancia Giordano 2-4 40054Busto (BO) Italy Tel: +39051 899689 Fax: +39051 899981
www.vincicosp.com - SpA

MULTIPLE PUMPS – SINGLE ELEMENTS

DIMENSIONAL CHECK

The correct dimensioning of a multiple pump requires an opportune verification on the mechanical resistance considering the specific working conditions. Therefore **IT IS RECOMMENDED** to do a dimensional check during the engineering phase in order to have a coherent choice with the real system capabilities.

The required data for the verification are mainly the **displacements** and **the working pressures** of each element. Starting from these basic data it is possible to find out the torque that is created on each driving shaft, both analytically than graphically.

ANALYTICAL PROCEDURE

To calculate analytically the transmitted torque, we assume that

- v_i = element displacement expressed in cc/rev.
- Δp = pressure difference between inlet and outlet expressed in bar
- η_m = mechanical efficiency that we can assume as 0.9

The transmitted torque is obtained by this simple equation.

$$T_{elem} = \frac{v_i \times \Delta p}{20 \times \pi \times \eta_m}$$

GRAPHICAL PROCEDURE

The identification of the torque transmitted by each single element can be obtained graphically starting from the below tables. When the Pressure/Torque table corresponding to the dimensional group is identified, choose the line on the graphic regarding the element displacement. Starting from the outlet pressure, get the corresponding torque.

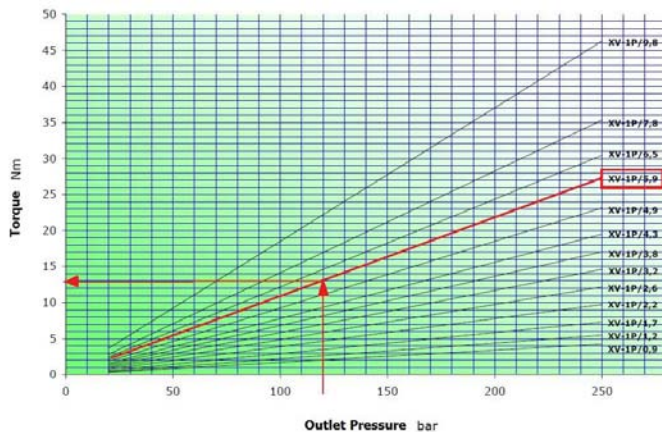

The verification require to compare the obtained torque value with the one recommended for each typology of connection or connecting shaft.

To each element, starting from the final one, the torque coming from the previous ones must be added, using the following scheme:

FINAL ELEMENT VERIFICATION	$T_{elem_fin} \leq T_{fin}$
INTERMEDIATE ELEMENT VERIFICATION	$T_{elem_int} + T_{elem_int_preced} + T_{elem_fin} \leq T_{int}$
DRIVING ELEMENT VERIFICATION	$T_{elem_prim} + \dots + T_{elem_int} + \dots + T_{elem_fin} \leq T_{prim}$

MULTIPLE PUMPS – SINGLE ELEMENTS

The recommended values are summarized in the following tables:

TORQUES ALLOWED ON DRIVING PUMP SHAFT:

	SHAFT [IDENTIFIER] - CODE - DESCRIPTION	T Max [Nm]
XV-0P	[A] - CI001 - Parallel \varnothing 7 - M 7x1 - key thk sp.2	2.1
	[B] - CF001 - Milled shank \varnothing 7 - sp. 5	9,2
	[F] - CF005 - Milled shank \varnothing 7 - sp.4,5 L = 9	8.4
XV-1P	[A] - CI001 - Parallel \varnothing 12 - M10x1 - key thk. 3	25,8
	[B] - CI002 - Parallel \varnothing 12.7 - key thk. 3.2 (SAE)	32,8
	[C] - CF001 - Milled shank \varnothing 10 - thk.5 ("BH" Standard German)	13,8
	[D] - CF002 - Milled shank \varnothing 10 - thk.5	13,8
	[E] - CF003 - Milled shank \varnothing 11 - thk.6.63 (SAE)	25,8
	[F] - CO001 - Tapered 1:8 - \varnothing 10 - M7x1 - key thk.2.4	43.1
	[G] - CO002 - Tapered 1:8 - \varnothing 14 - M10x1 - key thk.3	119,8
	[I] - CO004 - Tapered 1:8 - \varnothing 12.7 - 5/16" 24UNF-2A - key thk.3.2 (SAE)	90,4
	[J] - SCF04 - Splined \varnothing 11.7 - z=6, H=17.5, m=1.6, DIN 5482 12x9	22,6
	[K] - SCF05 - Splined \varnothing 12.344, z=9, H=19, SAE J498 9T 20/40DB	32,2
	[L] - SCF02 - Splined \varnothing 11.9, z=15, H=17.5, m=0.75	42,8
	[O] - CO002+HK - Tapered 1:8 - \varnothing 14 - M10x1, HK 14-12, key thk.3	119,8
	[P] - CI001+HK - Parallel \varnothing 12 - M10x1 with bearing HK 14-12 - key thk.3	25,8
	[Q] - SCF01 - Splined \varnothing 11.9, z=15, H=9, m=0.75	42,8
	[R] - SCF03 - Splined \varnothing 11.9, z=15, H=9, m=0.75	42,8
	XV-2P	[A] - CI001 - Parallel \varnothing 15 - M6x1 - key thk.4
[B] - CI002 - Parallel \varnothing 15.875 – 1/4"28-UNF key thk.4 (SAE A)		67.5
[C] - CF001 - Miled shank \varnothing 15 - thk.8 ("BH" Standard German)		60.5
[E] - CO001 - Tapered 1:8 - \varnothing 17,4 - M12x1,5 - key thk.4		233.2
[F] - CO002 - Tapered 1:5 - \varnothing 17,4 - M12x1,5 - key thk.3		233.2
[G] - SCF02 - Splined \varnothing 16,5 - z=9, H=13, m=1.6 DIN 5482 17x14		86.1
[H] - SCF03 - Splined \varnothing 16.5 - z=9, H=18,8, m=1,6 DIN 5482 17x14		86.1
[I] - SCF04 - Splined \varnothing 15.456 z=9, H=22.5, SAE J498 9T 16/32DP		67.1
[K] - SCF05 - Splined \varnothing 16.5 z=9 H=8,1 m=1.6 DIN 5482 17x14		86.2
[L] - SCF01- Splined \varnothing 16.5 z=9 H=9,2 m=1.6 DIN 5482 17x14		86.2
[M] - CO001 - Tapered 1:8 - \varnothing 17,4 - M12x1,5 - key thk.3,2		233.2
XV-3P	[A] - CO001 - Tapered 1:8 - \varnothing 22 - M14x1.5 - key thk.4	482
	[B] - CI001 - Parallel \varnothing 20 - M8 - key thk.5	181
	[C] - SCF03 - Splined \varnothing 21.5, z=13, H=25, m=1,6	223
	[H] - CI004 - Parallel \varnothing 22.225– 1/4"28-UNF key thk.6.35 (SAE B)	180
	[I] - SCF04 - Splined \varnothing 21.8059, z=13, H=25, SAE J498 9T 16/32DP	264

MULTIPLE PUMPS – SINGLE ELEMENTS

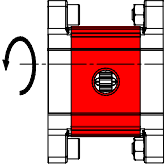
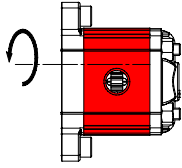
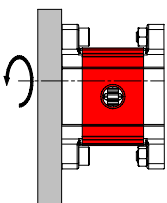
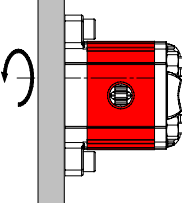
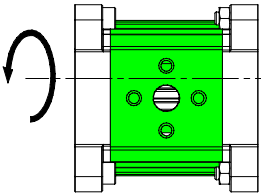
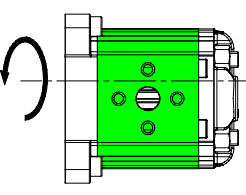
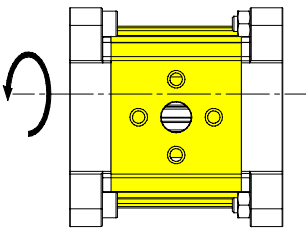
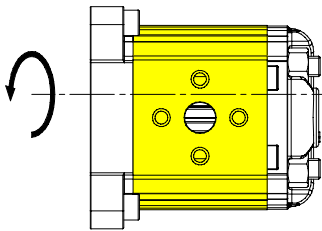
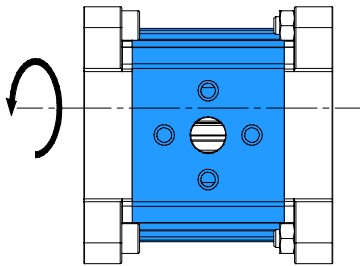
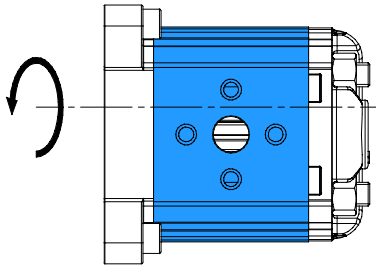

TORQUES ALLOWED ON FINAL AND INTERMEDIATE PUMP SHAFT:

Composition	Intermediate Pump Couple T_{int}	Final Pump Couple T_{fin}
0P + 0P	 3,7 Nm	 3,7 Nm
1P + 0P 2P + 0P 3P + 0P	 2,1 Nm	 2,1 Nm
1P + 1P 2P + 1P 3P + 1P	 42,8 Nm	 42,8 Nm
2P + 2P 3P + 3P	 86,2 Nm	 86,2 Nm
3P + 3P	 332 Nm	 332 Nm

MULTIPLE PUMPS – SINGLE ELEMENTS

Example of quadruple pump verification with primary taper shaft COP02:

Element typology	Displacement	Working Pressure
Driving	22 cc	150 bar
Intermediate 1	5.9 cc	120 bar
Intermediate 2	5.9 cc	100 bar
Final	1.2 cc	100 bar

Consequently through the calculation or graphical analysis

Motive Torque
58.39 Nm
12.53 Nm
10.44 Nm
2.12 Nm

The verification therefore is, starting from the final element:

Final element

$$T_{elem_fin} \leq T_{fin} \quad 2.12 \text{ Nm} < \quad \text{OK}$$

Intermediate Element 2

$$T_{elem_int} + T_{elem_int_preced} + T_{elem_fin} \leq T_{int} \quad 2.12 + 10.44 \text{ Nm} = 12.56 \text{ Nm} < \quad \text{OK}$$

Intermediate Element 1

$$T_{elem_int} + T_{elem_int_preced} + T_{elem_fin} \leq T_{int} \quad 12.56 + 12.53 \text{ Nm} = 25.09 \text{ Nm} < \quad \text{OK}$$

Driving Element

$$T_{elem_prim} + \dots + T_{elem_int} + \dots + T_{elem_fin} \leq T_{prim} \quad 25.09 + 58.39 \text{ Nm} = 83.48 \text{ Nm} < 233.2 \text{ Nm} \quad \text{OK}$$

General Notes:

For assemblies with a coupling, you should choose one as balanced as possible in order to reduce the vibrations and dynamic stresses to which the pump shaft may be subject.

Always make sure that the torque applied is less than or equal to the admissible torque of the shaft.

Do not apply a direct axial or radial load on the pump shaft; if necessary, use suitable supports.

Always use well-filtered oils containing no water or other emulsifying substance.

Never run the pump with oil and air solutions.

For pumps with outlets on the flange, it is recommended not to exceed a flow rate of

4 l/min	XV-0P
20 l/min.	XV-1P
35 l/min	XV-2P

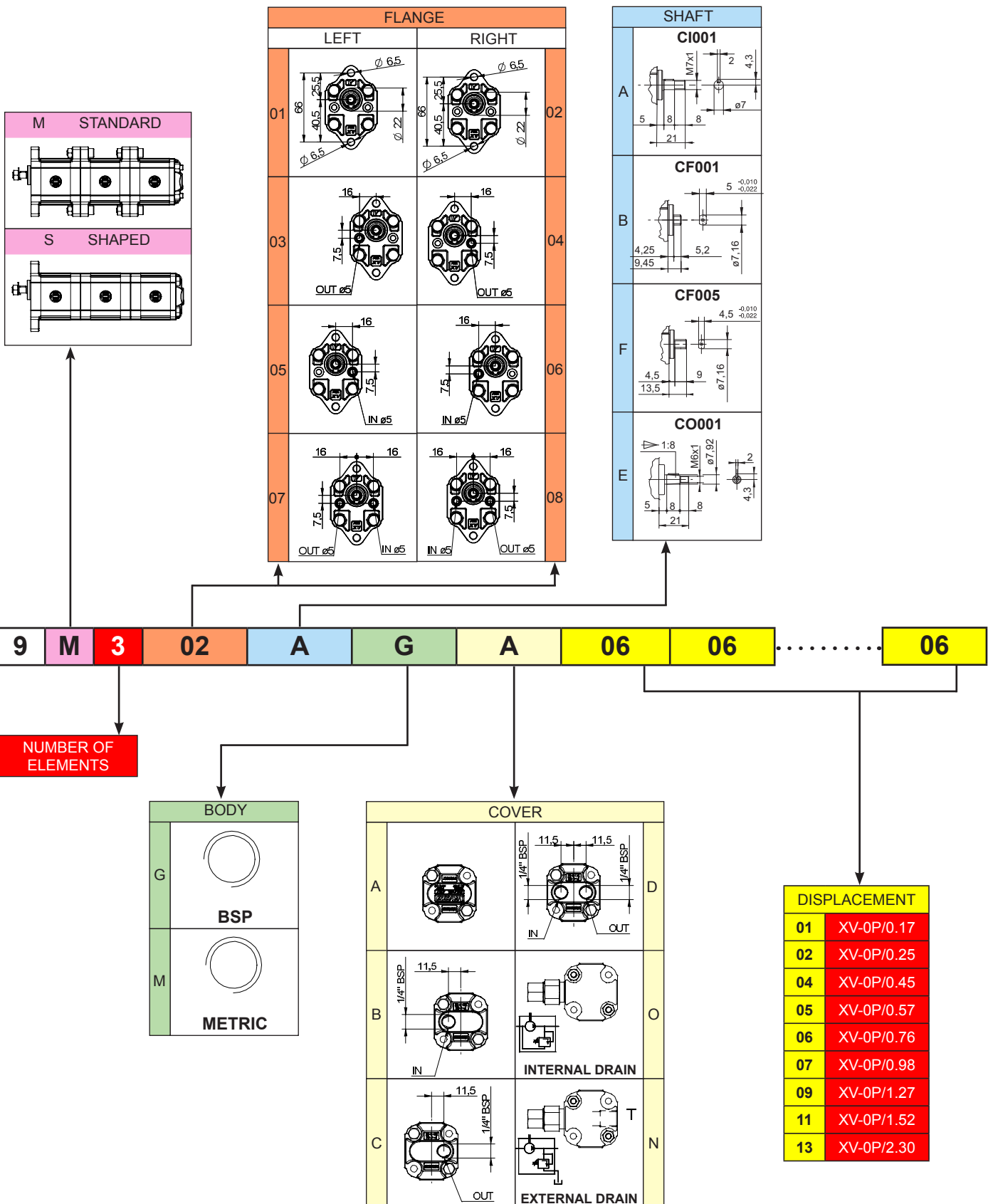

MULTIPLE PUMP XV-0

Ø 22 FLANGE

XV-0

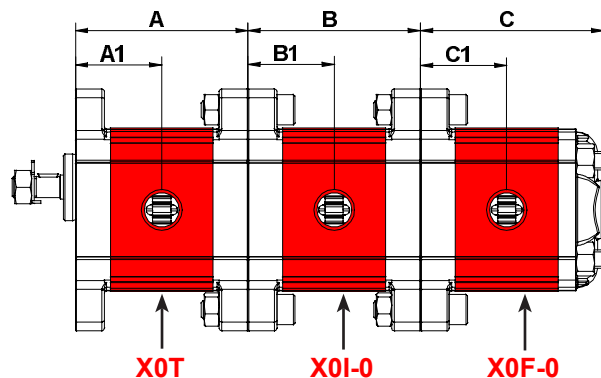
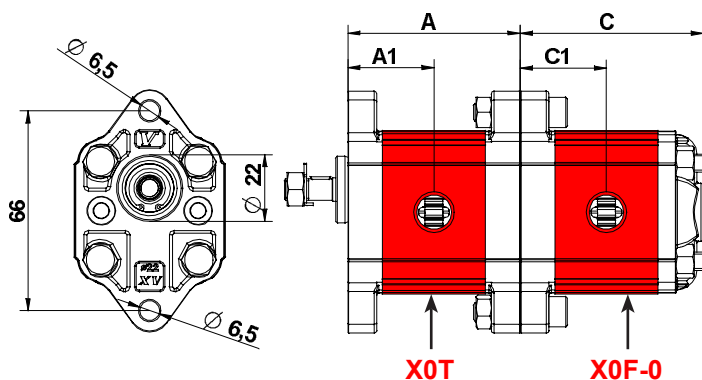
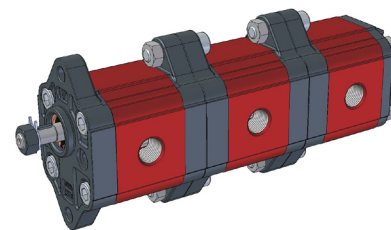

TYPE	Displacem	A	A1	B	B1	C	C1	P1	P3	Min speed	Max speed
	cc/rev	mm	mm	mm	mm	mm	mm	bar	bar	rpm	rpm
XV-0 / 0,17	0,16	52,3	26,2	52,3	26,2	55,8	26,2	220	260	700	9000
XV-0 / 0,25	0,24	52,9	26,5	52,9	26,5	56,4	26,5	220	260	700	9000
XV-0 / 0,45	0,45	54,5	27,3	54,5	27,3	58	27,3	220	280	700	9000
XV-0 / 0,57	0,56	55,5	27,8	55,5	27,8	59	27,8	220	280	700	9000
XV-0 / 0,76	0,75	57	28,5	57	28,5	60,5	28,5	220	280	700	9000
XV-0 / 0,98	0,92	58,5	29,3	58,5	29,3	62	29,3	220	280	700	6000
XV-0 / 1,27	1,26	61	30,5	61	30,5	64,5	30,5	220	280	700	6000
XV-0 / 1,52	1,48	63	31,5	63	31,5	66,5	31,5	220	280	700	6000
XV-0 / 2,30	2,28	69	34,5	69	34,5	72,5	34,5	220	210	700	5000

MULTIPLE PUMP XV-0

ø 22 "BH" Body-Shaped FLANGE

XV-0

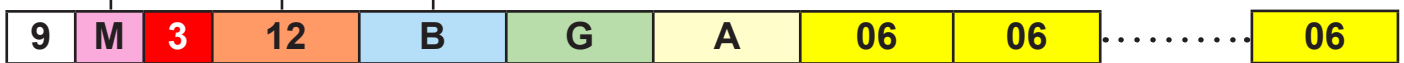
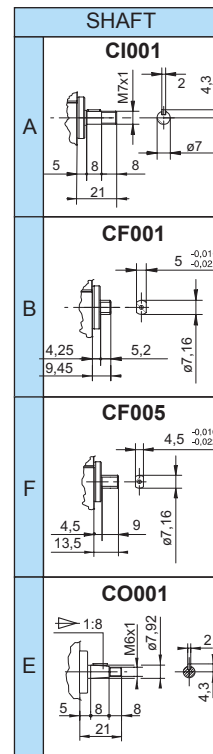
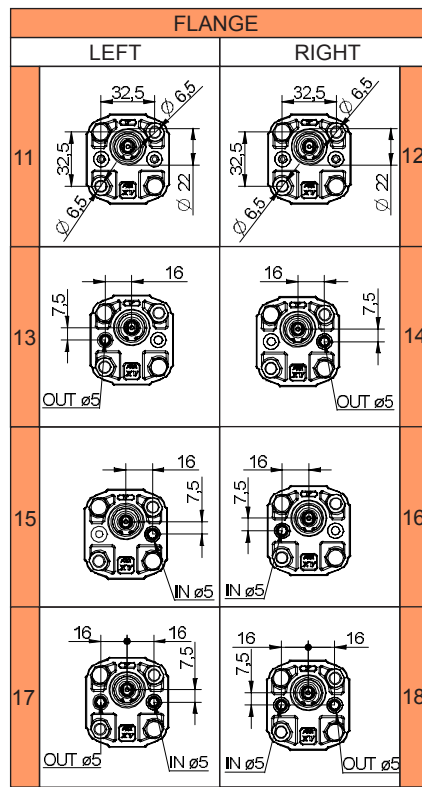
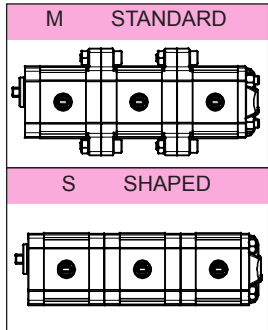

NUMBER OF ELEMENTS

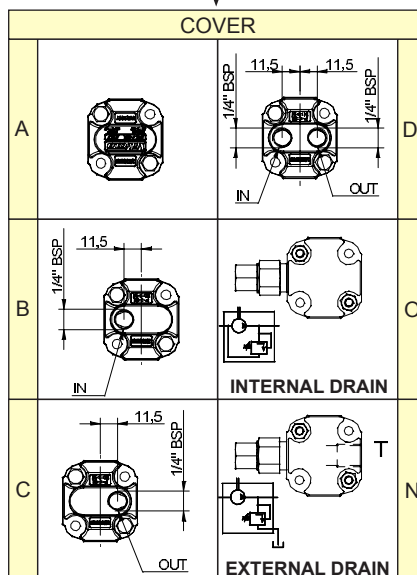
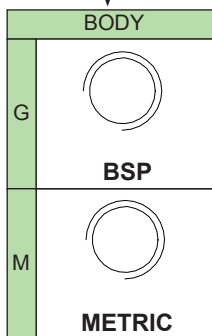

DISPLACEMENT	
01	XV-0P/0.17
02	XV-0P/0.25
04	XV-0P/0.45
05	XV-0P/0.57
06	XV-0P/0.76
07	XV-0P/0.98
09	XV-0P/1.27
11	XV-0P/1.52
13	XV-0P/2.30

MULTIPLE PUMP XV-0

Ø 22 "BH" Body-Shaped FLANGE

XV-0

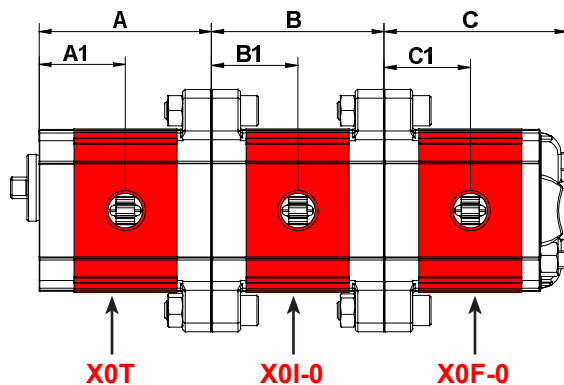
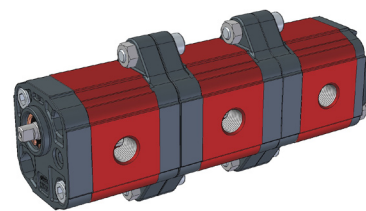
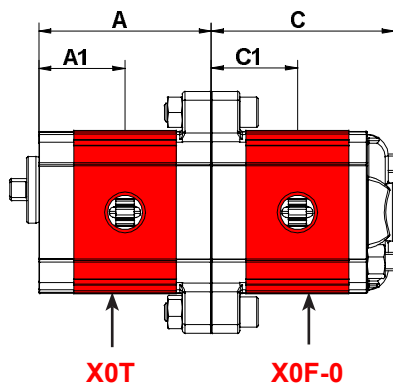
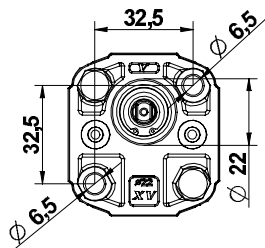

TYPE	Displacem.	A	A1	B	B1	C	C1	P1	P3	Min speed	Max speed
	cc/rev	mm	mm	mm	mm	mm	mm	bar	bar	rpm	rpm
XV-0 / 0,17	0,16	52,3	26,2	52,3	26,2	55,8	26,2	220	260	700	9000
XV-0 / 0,25	0,24	52,9	26,5	52,9	26,5	56,4	26,5	220	260	700	9000
XV-0 / 0,45	0,45	54,5	27,3	54,5	27,3	58	27,3	220	280	700	9000
XV-0 / 0,57	0,56	55,5	27,8	55,5	27,8	59	27,8	220	280	700	9000
XV-0 / 0,76	0,75	57	28,5	57	28,5	60,5	28,5	220	280	700	9000
XV-0 / 0,98	0,92	58,5	29,3	58,5	29,3	62	29,3	220	280	700	6000
XV-0 / 1,27	1,26	61	30,5	61	30,5	64,5	30,5	220	280	700	6000
XV-0 / 1,52	1,48	63	31,5	63	31,5	66,5	31,5	220	280	700	6000
XV-0 / 2,30	2,28	69	34,5	69	34,5	72,5	34,5	220	210	700	5000

MULTIPLE PUMP XV-0

ø 22 "HY" Body-Shaped FLANGE

XV-0

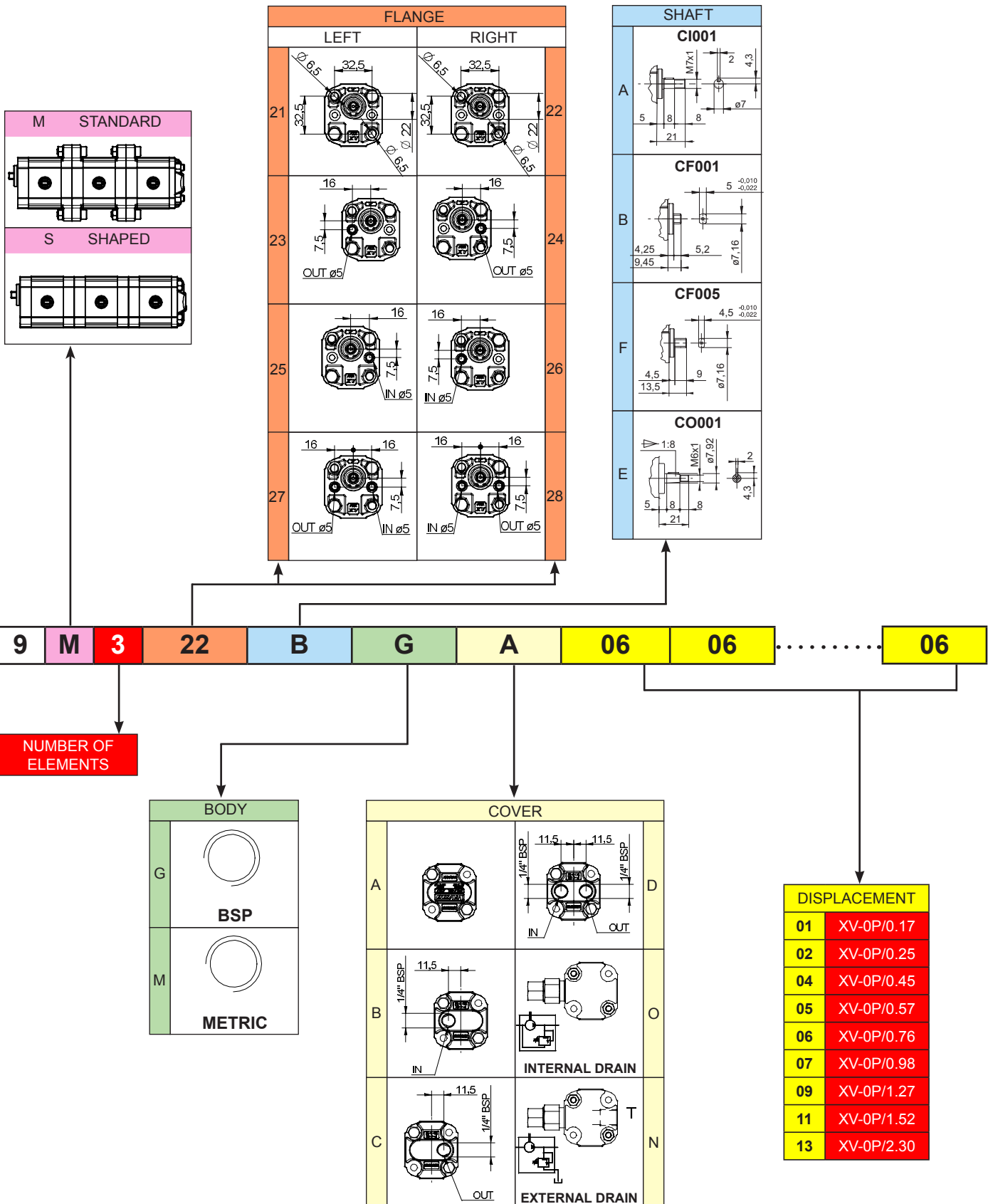

MULTIPLE PUMP XV-1

Ø 22 "HY" Body-Shaped FLANGE

XV-0

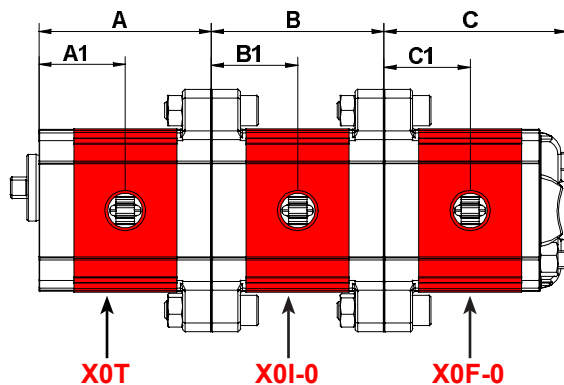
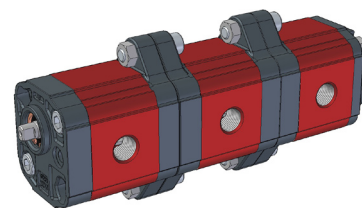
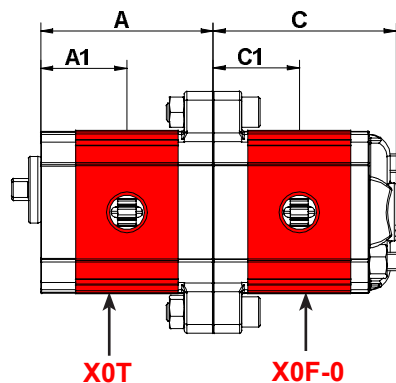
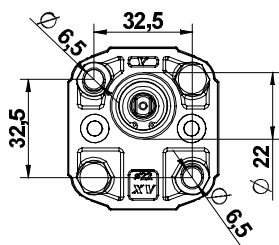

TYPE	Displacem.	A	A1	B	B1	C	C1	P1	P3	Min speed	Max speed
	cc/rev	mm	mm	mm	mm	mm	mm	bar	bar	rpm	rpm
XV-0 / 0,17	0,16	52,3	26,2	52,3	26,2	55,8	26,2	220	260	700	9000
XV-0 / 0,25	0,24	52,9	26,5	52,9	26,5	56,4	26,5	220	260	700	9000
XV-0 / 0,45	0,45	54,5	27,3	54,5	27,3	58	27,3	220	280	700	9000
XV-0 / 0,57	0,56	55,5	27,8	55,5	27,8	59	27,8	220	280	700	9000
XV-0 / 0,76	0,75	57	28,5	57	28,5	60,5	28,5	220	280	700	9000
XV-0 / 0,98	0,92	58,5	29,3	58,5	29,3	62	29,3	220	280	700	6000
XV-0 / 1,27	1,26	61	30,5	61	30,5	64,5	30,5	220	280	700	6000
XV-0 / 1,52	1,48	63	31,5	63	31,5	66,5	31,5	220	280	700	6000
XV-0 / 2,30	2,28	69	34,5	69	34,5	72,5	34,5	220	210	700	5000

MULTIPLE PUMP XV-1

ø 25,4 FLANGE

XV-1

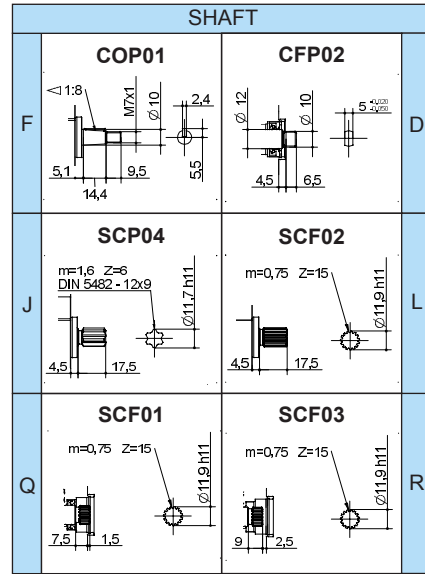
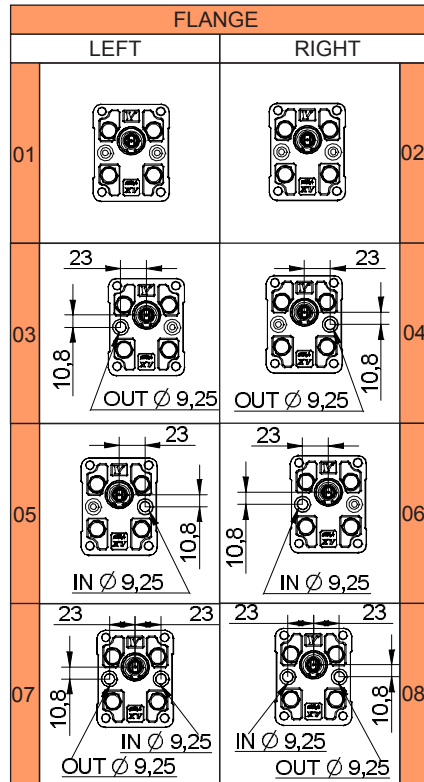
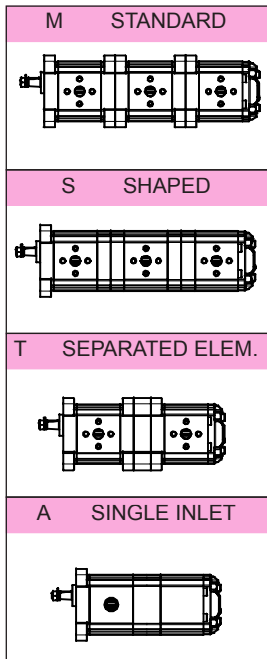

9 **M** **3** **02** **F** **C** **A** **25** **25** **25**

NUMBER OF ELEMENTS

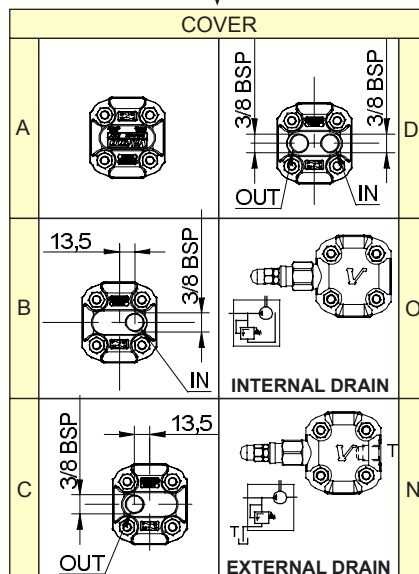
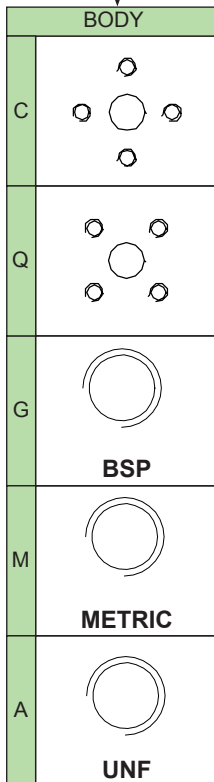

DISPLACEMENT	
16	XV-1P/0.9
17	XV-1P/1.2
18	XV-1P/1.7
20	XV-1P/2.2
21	XV-1P/2.6
23	XV-1P/3.2
25	XV-1P/3.8
27	XV-1P/4.3
29	XV-1P/4.9
31	XV-1P/5.9
32	XV-1P/6.5
34	XV-1P/7.8
36	XV-1P/9.8

DISPLACEMENT	
01	XV-0P/0.17
02	XV-0P/0.25
04	XV-0P/0.45
05	XV-0P/0.57
06	XV-0P/0.76
07	XV-0P/0.98
09	XV-0P/1.27
11	XV-0P/1.52
13	XV-0P/2.30

MULTIPLE PUMP XV-1

Ø 25,4 FLANGE

XV-1

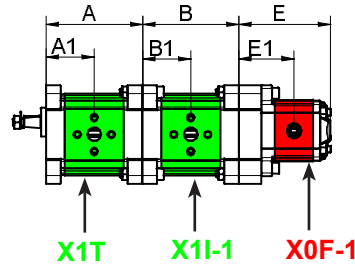
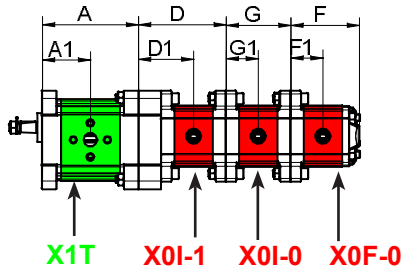
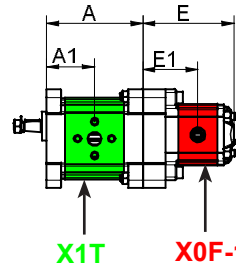
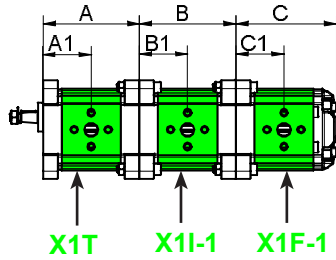
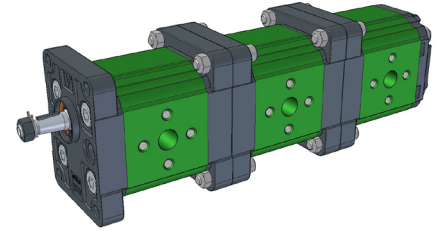
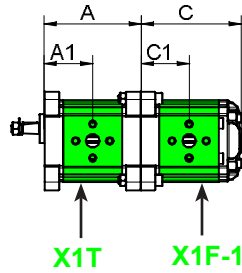
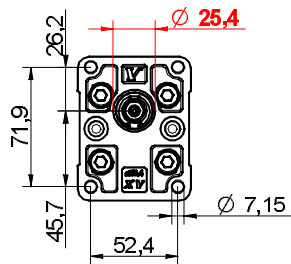

SEPARATED STAGES

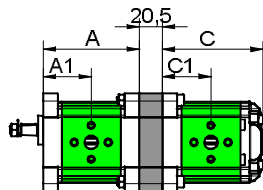

SINGLE INLET

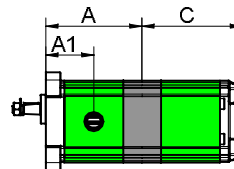

* = SPECIAL ELEMENT, please contact our customer service for details.

TYPE	Displacement cc/rev	A mm	A1 mm	B mm	B1 mm	C mm	C1 mm	P1 bar	P3 bar	Min speed rpm	Max speed rpm
XV-1 / 0,9	0,91	74,5	37,3	74,5	37,3	78	37,3	240	280	700	6000
XV-1 / 1,2	1,17	75,5	37,8	75,5	37,8	79	37,8	250	290	700	6000
XV-1 / 1,7	1,56	77	38,5	77	38,5	80,5	38,5	250	290	700	6000
XV-1 / 2,2	2,08	79	39,5	79	39,5	82,5	39,5	250	290	700	6000
XV-1 / 2,6	2,60	81	40,5	81	40,5	84,5	40,5	250	300	700	6000
XV-1 / 3,2	3,12	83	41,5	83	41,5	86	41,5	250	300	700	6000
XV-1 / 3,8	3,64	85	42,5	85	42,5	88,5	42,5	250	300	700	6000
XV-1 / 4,3	4,26	87	43,5	87	43,5	90,5	43,5	250	300	700	6000
XV-1 / 4,9	4,94	90	45	90	45	93,5	45	250	300	700	6000
XV-1 / 5,9	5,85	93,5	46,8	93,5	46,8	97	46,8	250	300	700	5000
XV-1 / 6,5	6,50	96	48	96	48	99,5	48	250	300	700	5000
XV-1 / 7,8	7,54	100	50	100	50	103,5	50	220	260	700	5000
XV-1 / 9,8	9,88	109	54,5	109	54,5	112,5	54,5	190	230	700	4000

TYPE	Displacem. cc/rev	D mm	D1 mm	E mm	E1 mm	F mm	F1 mm	G mm	G1 mm	P1 bar	P3 bar	Min speed rpm	Max speed rpm
XV-0 / 0,17	0,16	72,3	46,2	75,8	46,2	55,8	26,2	52,3	26,2	220	260	700	9000
XV-0 / 0,25	0,24	72,9	46,5	76,4	46,5	56,4	26,5	52,9	26,5	220	260	700	9000
XV-0 / 0,45	0,45	74,5	47,3	78	47,3	58	27,3	54,5	27,3	220	280	700	9000
XV-0 / 0,57	0,56	75,5	47,8	79	47,8	59	27,8	55,5	27,8	220	280	700	9000
XV-0 / 0,76	0,75	77	48,5	80,5	48,5	60,5	28,5	57	28,5	220	280	700	9000
XV-0 / 0,98	0,92	78,5	49,3	82	49,3	62	29,3	58,5	29,3	220	280	700	6000
XV-0 / 1,27	1,26	81	50,5	84,5	50,5	64,5	30,5	61	30,5	220	280	700	6000
XV-0 / 1,52	1,48	83	51,5	86,5	51,5	66,5	31,5	63	31,5	220	280	700	6000
XV-0 / 2,30	2,28	89	54,5	92,5	54,5	72,5	34,5	69	34,5	220	210	700	5000

MULTIPLE PUMP XV-1

Ø 30 FLANGE

XV-1

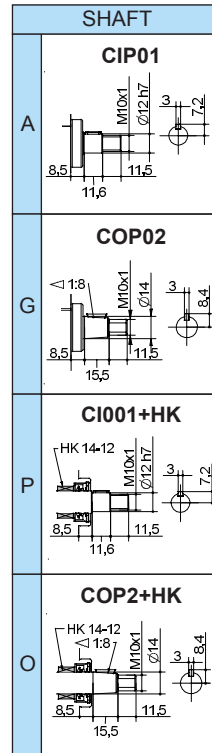
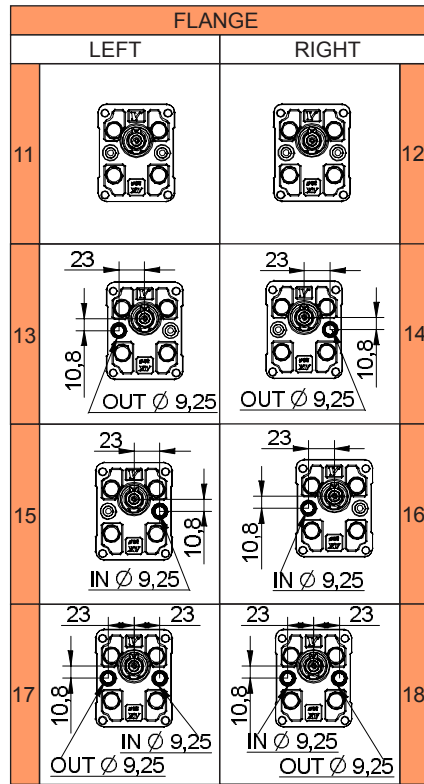
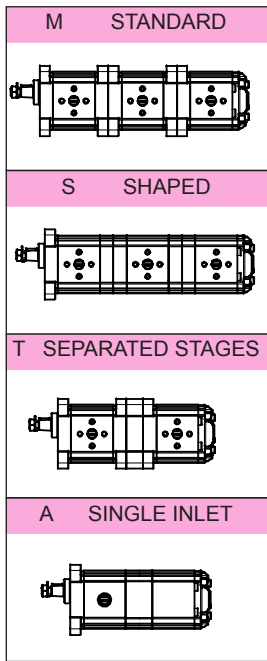

9 M 3 12 G C A 25 25 25

NUMBER OF ELEMENTS

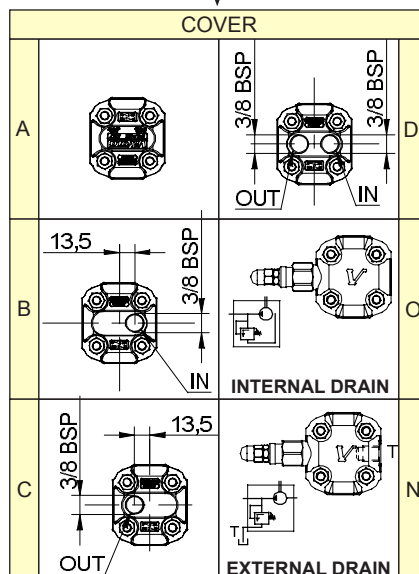
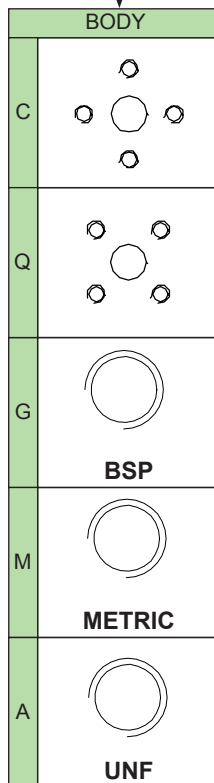

DISPLACEMENT	
16	XV-1P/0.9
17	XV-1P/1.2
18	XV-1P/1.7
20	XV-1P/2.2
21	XV-1P/2.6
23	XV-1P/3.2
25	XV-1P/3.8
27	XV-1P/4.3
29	XV-1P/4.9
31	XV-1P/5.9
32	XV-1P/6.5
34	XV-1P/7.8
36	XV-1P/9.8

DISPLACEMENT	
01	XV-0P/0.17
02	XV-0P/0.25
04	XV-0P/0.45
05	XV-0P/0.57
06	XV-0P/0.76
07	XV-0P/0.98
09	XV-0P/1.27
11	XV-0P/1.52
13	XV-0P/2.30

MULTIPLE PUMP XV-1

Ø 30 FLANGE

XV-1

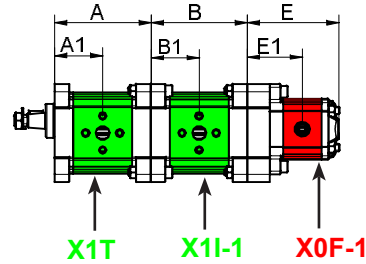
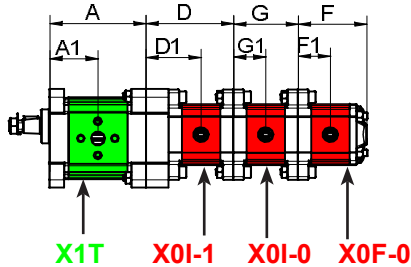
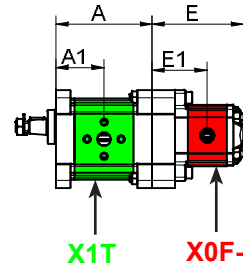
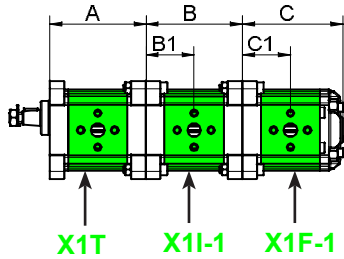
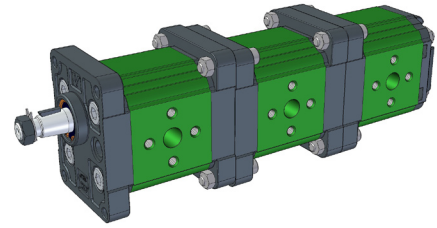
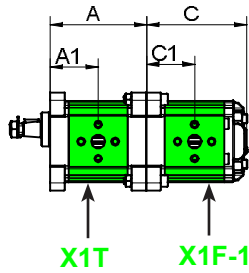
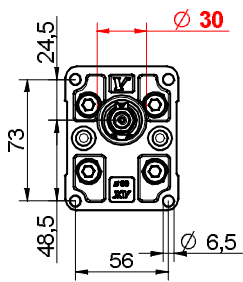

SEPARATED STAGES

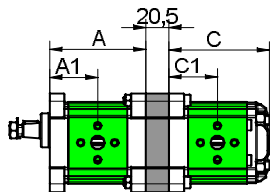

SINGLE INLET

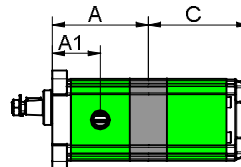

* = SPECIAL ELEMENT, please contact our customer service for details.

TYPE	Displacement cc/rev	A mm	A1 mm	B mm	B1 mm	C mm	C1 mm	P1 bar	P3 bar	Min speed rpm	Max speed rpm
XV-1 / 0,9	0,91	74,5	37,3	74,5	37,3	78	37,3	240	280	700	6000
XV-1 / 1,2	1,17	75,5	37,8	75,5	37,8	79	37,8	250	290	700	6000
XV-1 / 1,7	1,56	77	38,5	77	38,5	80,5	38,5	250	290	700	6000
XV-1 / 2,2	2,08	79	39,5	79	39,5	82,5	39,5	250	290	700	6000
XV-1 / 2,6	2,60	81	40,5	81	40,5	84,5	40,5	250	300	700	6000
XV-1 / 3,2	3,12	83	41,5	83	41,5	86	41,5	250	300	700	6000
XV-1 / 3,8	3,64	85	42,5	85	42,5	88,5	42,5	250	300	700	6000
XV-1 / 4,3	4,26	87	43,5	87	43,5	90,5	43,5	250	300	700	6000
XV-1 / 4,9	4,94	90	45	90	45	93,5	45	250	300	700	6000
XV-1 / 5,9	5,85	93,5	46,8	93,5	46,8	97	46,8	250	300	700	5000
XV-1 / 6,5	6,50	96	48	96	48	99,5	48	250	300	700	5000
XV-1 / 7,8	7,54	100	50	100	50	103,5	50	220	260	700	5000
XV-1 / 9,8	9,88	109	54,5	109	54,5	112,5	54,5	190	230	700	4000

TYPE	Displacement cc/rev	D mm	D1 mm	E mm	E1 mm	F mm	F1 mm	G mm	G1 mm	P1 bar	P3 bar	Min speed rpm	Max speed rpm
XV-0 / 0,17	0,16	72,3	46,2	75,8	46,2	55,8	26,2	52,3	26,2	220	260	700	9000
XV-0 / 0,25	0,24	72,9	46,5	76,4	46,5	56,4	26,5	52,9	26,5	220	260	700	9000
XV-0 / 0,45	0,45	74,5	47,3	78	47,3	58	27,3	54,5	27,3	220	280	700	9000
XV-0 / 0,57	0,56	75,5	47,8	79	47,8	59	27,8	55,5	27,8	220	280	700	9000
XV-0 / 0,76	0,75	77	48,5	80,5	48,5	60,5	28,5	57	28,5	220	280	700	9000
XV-0 / 0,98	0,92	78,5	49,3	82	49,3	62	29,3	58,5	29,3	220	280	700	6000
XV-0 / 1,27	1,26	81	50,5	84,5	50,5	64,5	30,5	61	30,5	220	280	700	6000
XV-0 / 1,52	1,48	83	51,5	86,5	51,5	66,5	31,5	63	31,5	220	280	700	6000
XV-0 / 2,30	2,28	89	54,5	92,5	54,5	72,5	34,5	69	34,5	220	210	700	5000

MULTIPLE PUMP XV-1

ø 32 "BH" Body-Shaped FLANGE

XV-1

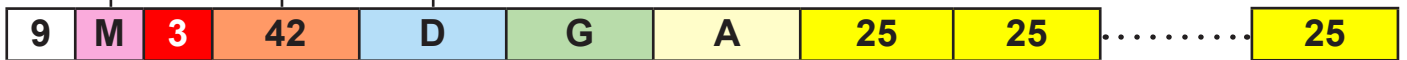
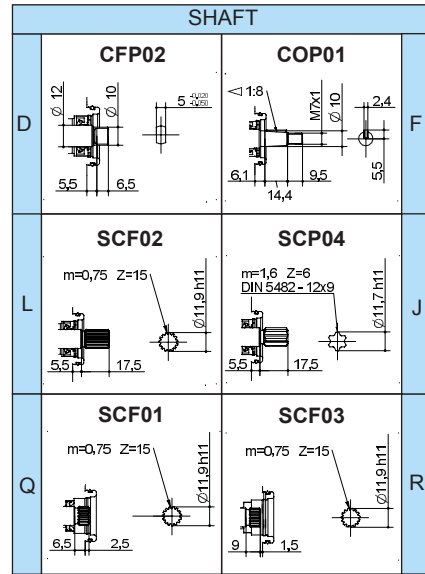
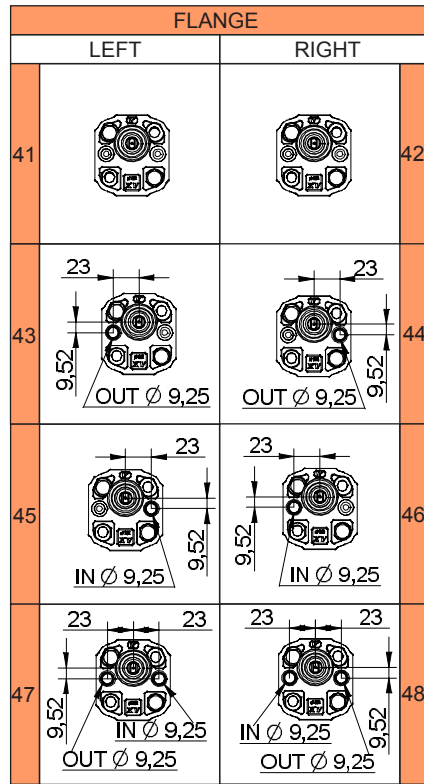
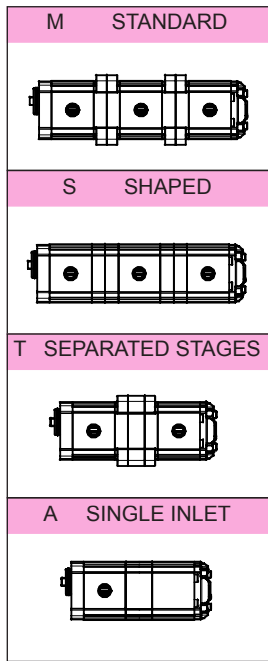

NUMBER OF ELEMENTS

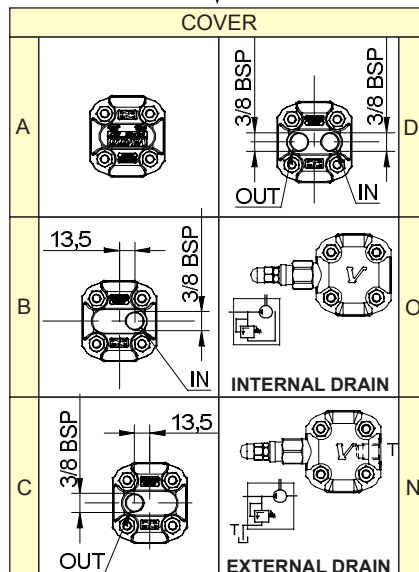
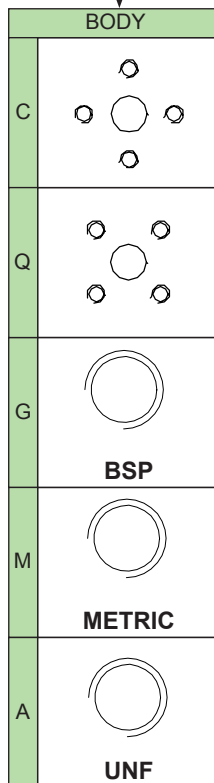

DISPLACEMENT	
16	XV-1P/0.9
17	XV-1P/1.2
18	XV-1P/1.7
20	XV-1P/2.2
21	XV-1P/2.6
23	XV-1P/3.2
25	XV-1P/3.8
27	XV-1P/4.3
29	XV-1P/4.9
31	XV-1P/5.9
32	XV-1P/6.5
34	XV-1P/7.8
36	XV-1P/9.8

DISPLACEMENT	
01	XV-0P/0.17
02	XV-0P/0.25
04	XV-0P/0.45
05	XV-0P/0.57
06	XV-0P/0.76
07	XV-0P/0.98
09	XV-0P/1.27
11	XV-0P/1.52
13	XV-0P/2.30

MULTIPLE PUMP XV-1

ø 32 "BH" Body-Shaped FLANGE

XV-1

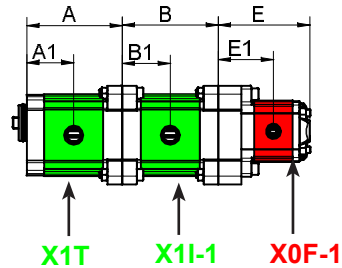
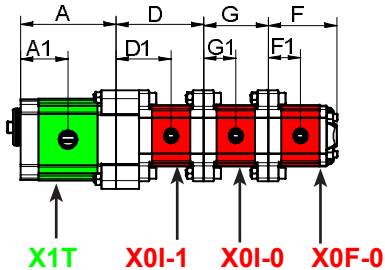
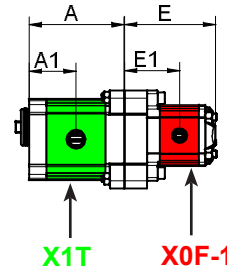
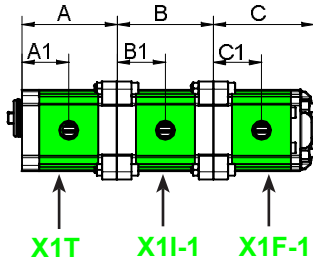
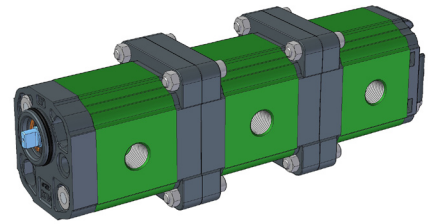
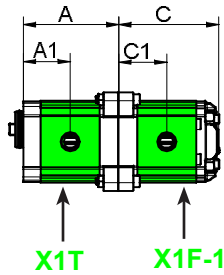
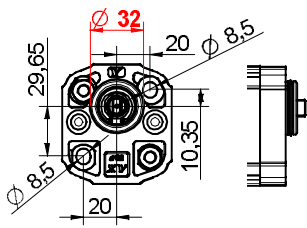

SEPARATED STAGES

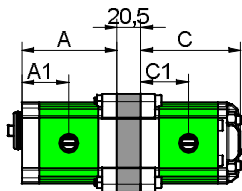

SINGLE INLET

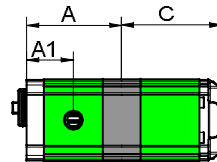

* = SPECIAL ELEMENT, please contact our customer service for details.

TYPE	Displacement cc/rev	A mm	A1 mm	B mm	B1 mm	C mm	C1 mm	P1 bar	P3 bar	Min speed rpm	Max speed rpm
XV-1 / 0,9	0,91	73,5	36,3	74,5	37,3	78	37,3	240	280	700	6000
XV-1 / 1,2	1,17	74,5	36,8	75,5	37,8	79	37,8	250	290	700	6000
XV-1 / 1,7	1,56	76	37,5	77	38,5	80,5	38,5	250	290	700	6000
XV-1 / 2,2	2,08	78	38,5	79	39,5	82,5	39,5	250	290	700	6000
XV-1 / 2,6	2,60	80	39,5	81	40,5	84,5	40,5	250	300	700	6000
XV-1 / 3,2	3,12	82	40,5	83	41,5	86	41,5	250	300	700	6000
XV-1 / 3,8	3,64	84	41,5	85	42,5	88,5	42,5	250	300	700	6000
XV-1 / 4,3	4,26	86	42,5	87	43,5	90,5	43,5	250	300	700	6000
XV-1 / 4,9	4,94	89	44	90	45	93,5	45	250	300	700	6000
XV-1 / 5,9	5,85	92,5	45,8	93,5	46,8	97	46,8	250	300	700	5000
XV-1 / 6,5	6,50	95	47	96	48	99,5	48	250	300	700	5000
XV-1 / 7,8	7,54	99	49	100	50	103,5	50	220	260	700	5000
XV-1 / 9,8	9,88	108	53,5	109	54,5	112,5	54,5	190	230	700	4000

TYPE	Displacement cc/rev	D mm	D1 mm	E mm	E1 mm	F mm	F1 mm	G mm	G1 mm	P1 bar	P3 bar	Min speed rpm	Max speed rpm
XV-0 / 0,17	0,16	72,3	46,2	75,8	46,2	55,8	26,2	52,3	26,2	220	260	700	9000
XV-0 / 0,25	0,24	72,9	46,5	76,4	46,5	56,4	26,5	52,9	26,5	220	260	700	9000
XV-0 / 0,45	0,45	74,5	47,3	78	47,3	58	27,3	54,5	27,3	220	280	700	9000
XV-0 / 0,57	0,56	75,5	47,8	79	47,8	59	27,8	55,5	27,8	220	280	700	9000
XV-0 / 0,76	0,75	77	48,5	80,5	48,5	60,5	28,5	57	28,5	220	280	700	9000
XV-0 / 0,98	0,92	78,5	49,3	82	49,3	62	29,3	58,5	29,3	220	280	700	6000
XV-0 / 1,27	1,26	81	50,5	84,5	50,5	64,5	30,5	61	30,5	220	280	700	6000
XV-0 / 1,52	1,48	83	51,5	86,5	51,5	66,5	31,5	63	31,5	220	280	700	6000
XV-0 / 2,30	2,28	89	54,5	92,5	54,5	72,5	34,5	69	34,5	220	210	700	5000

MULTIPLE PUMP XV-1

32 "HY" Body-Shaped FLANGE

XV-1

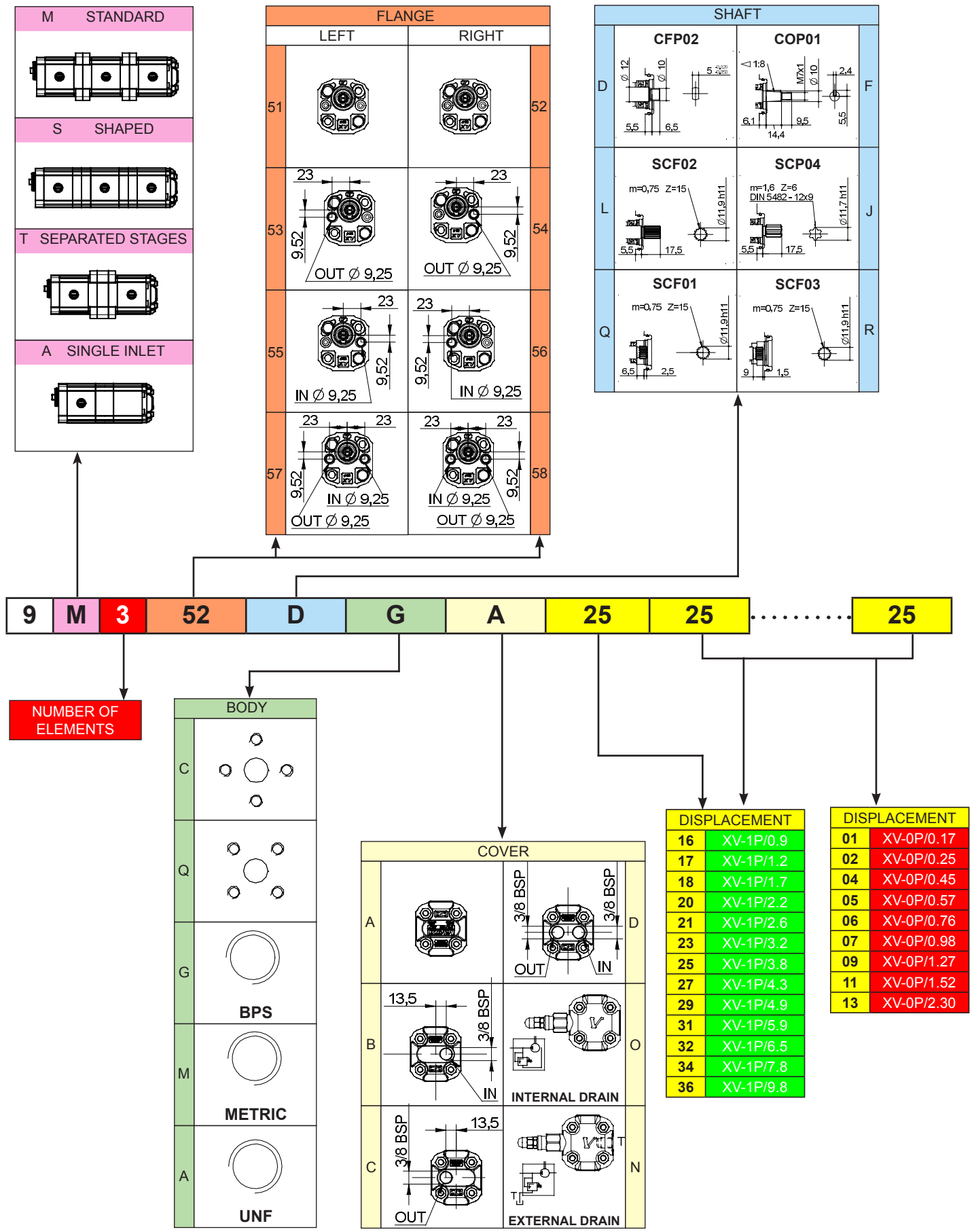

MULTIPLE PUMP XV-1

32 "HY" Body-Shaped FLANGE

XV-1

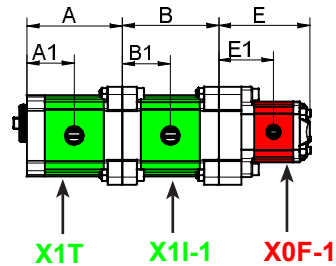
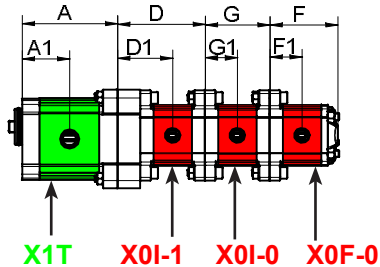
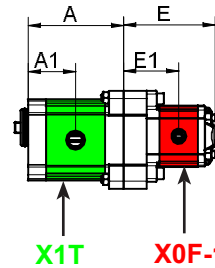
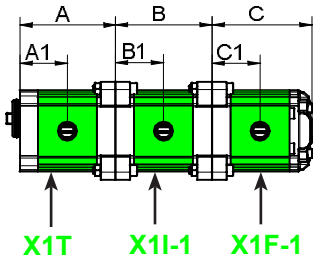
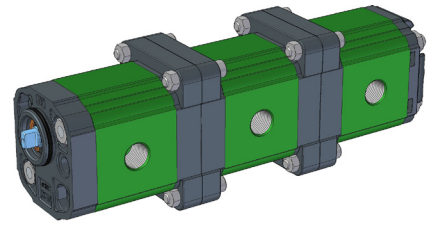
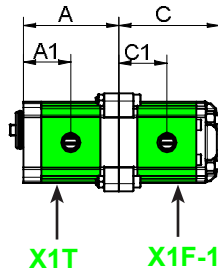
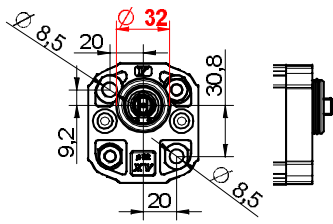

SEPARATED STAGES

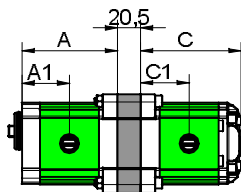

SINGLE INLET

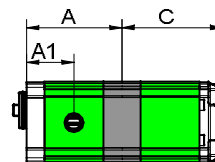

* = SPECIAL ELEMENT, please contact our customer service for details.

TYPE	Displacement cc/rev	A mm	A1 mm	B mm	B1 mm	C mm	C1 mm	P1 bar	P3 bar	Min speed rpm	Max speed rpm
XV-1 / 0,9	0,91	73,5	36,3	74,5	37,3	78	37,3	240	280	700	6000
XV-1 / 1,2	1,17	74,5	36,8	75,5	37,8	79	37,8	250	290	700	6000
XV-1 / 1,7	1,56	76	37,5	77	38,5	80,5	38,5	250	290	700	6000
XV-1 / 2,2	2,08	78	38,5	79	39,5	82,5	39,5	250	290	700	6000
XV-1 / 2,6	2,60	80	39,5	81	40,5	84,5	40,5	250	300	700	6000
XV-1 / 3,2	3,12	82	40,5	83	41,5	86	41,5	250	300	700	6000
XV-1 / 3,8	3,64	84	41,5	85	42,5	88,5	42,5	250	300	700	6000
XV-1 / 4,3	4,26	86	42,5	87	43,5	90,5	43,5	250	300	700	6000
XV-1 / 4,9	4,94	89	44	90	45	93,5	45	250	300	700	6000
XV-1 / 5,9	5,85	92,5	45,8	93,5	46,8	97	46,8	250	300	700	5000
XV-1 / 6,5	6,50	95	47	96	48	99,5	48	250	300	700	5000
XV-1 / 7,8	7,54	99	49	100	50	103,5	50	220	260	700	5000
XV-1 / 9,8	9,88	108	53,5	109	54,5	112,5	54,5	190	230	700	4000

TYPE	Displacement cc/rev	D mm	D1 mm	E mm	E1 mm	F mm	F1 mm	G mm	G1 mm	P1 bar	P3 bar	Min speed rpm	Max speed rpm
XV-0 / 0,17	0,16	72,3	46,2	75,8	46,2	55,8	26,2	52,3	26,2	220	260	700	9000
XV-0 / 0,25	0,24	72,9	46,5	76,4	46,5	56,4	26,5	52,9	26,5	220	260	700	9000
XV-0 / 0,45	0,45	74,5	47,3	78	47,3	58	27,3	54,5	27,3	220	280	700	9000
XV-0 / 0,57	0,56	75,5	47,8	79	47,8	59	27,8	55,5	27,8	220	280	700	9000
XV-0 / 0,76	0,75	77	48,5	80,5	48,5	60,5	28,5	57	28,5	220	280	700	9000
XV-0 / 0,98	0,92	78,5	49,3	82	49,3	62	29,3	58,5	29,3	220	280	700	6000
XV-0 / 1,27	1,26	81	50,5	84,5	50,5	64,5	30,5	61	30,5	220	280	700	6000
XV-0 / 1,52	1,48	83	51,5	86,5	51,5	66,5	31,5	63	31,5	220	280	700	6000
XV-0 / 2,30	2,28	89	54,5	92,5	54,5	72,5	34,5	69	34,5	220	210	700	5000

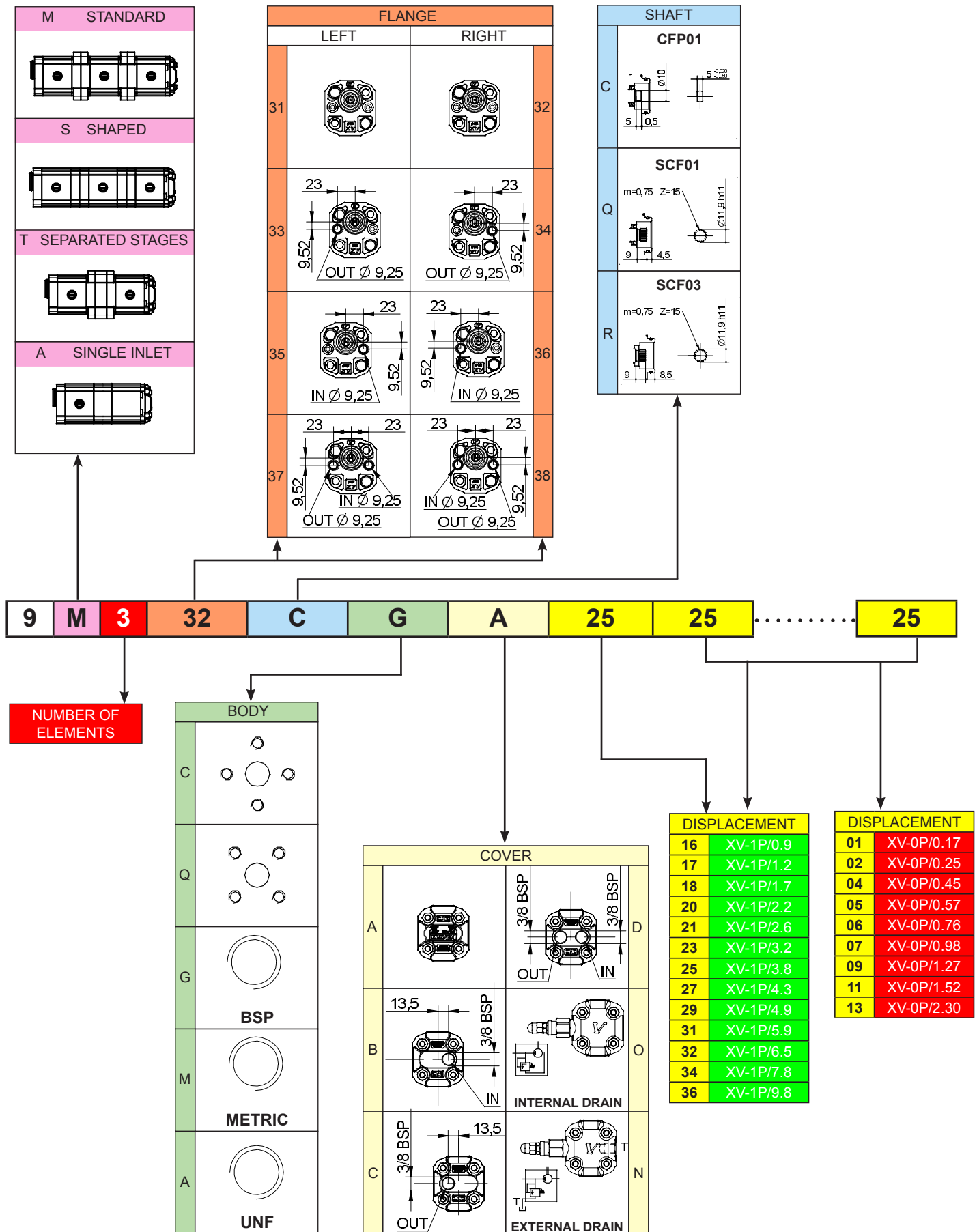

MULTIPLE PUMP XV-1

32 "BH" Body-Shaped FLANGE GERMAN STANDARD

XV-1

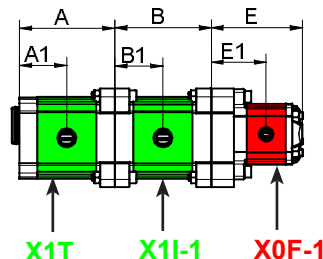
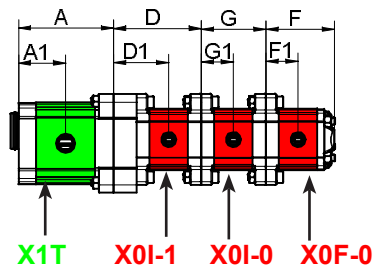
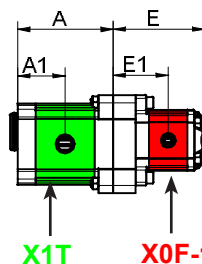
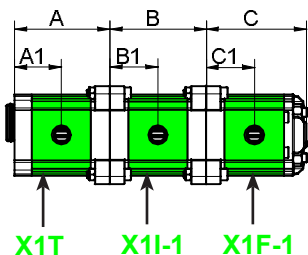
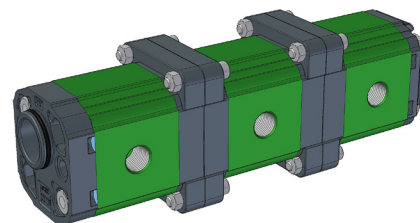
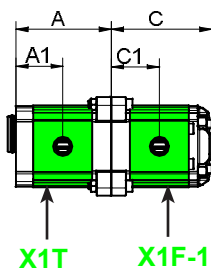
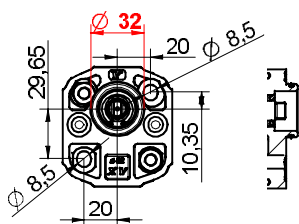

SEPARATED STAGES

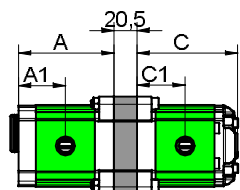

SINGLE INLET

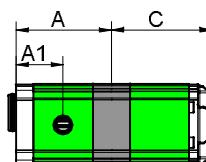

* = SPECIAL ELEMENT, please contact our customer service for details.

TYPE	Displacement cc/rev	A mm	A1 mm	B mm	B1 mm	C mm	C1 mm	P1 bar	P3 bar	Min speed rpm	Max speed rpm
XV-1 / 0,9	0,91	73,5	36,3	74,5	37,3	78	37,3	240	280	700	6000
XV-1 / 1,2	1,17	74,5	36,8	75,5	37,8	79	37,8	250	290	700	6000
XV-1 / 1,7	1,56	76	37,5	77	38,5	80,5	38,5	250	290	700	6000
XV-1 / 2,2	2,08	78	38,5	79	39,5	82,5	39,5	250	290	700	6000
XV-1 / 2,6	2,60	80	39,5	81	40,5	84,5	40,5	250	300	700	6000
XV-1 / 3,2	3,12	82	40,5	83	41,5	86	41,5	250	300	700	6000
XV-1 / 3,8	3,64	84	41,5	85	42,5	88,5	42,5	250	300	700	6000
XV-1 / 4,3	4,26	86	42,5	87	43,5	90,5	43,5	250	300	700	6000
XV-1 / 4,9	4,94	89	44	90	45	93,5	45	250	300	700	6000
XV-1 / 5,9	5,85	92,5	45,8	93,5	46,8	97	46,8	250	300	700	5000
XV-1 / 6,5	6,50	95	47	96	48	99,5	48	250	300	700	5000
XV-1 / 7,8	7,54	99	49	100	50	103,5	50	220	260	700	5000
XV-1 / 9,8	9,88	108	53,5	109	54,5	112,5	54,5	190	230	700	4000

TYPE	Displacement cc/rev	D mm	D1 mm	E mm	E1 mm	F mm	F1 mm	G mm	G1 mm	P1 bar	P3 bar	Min speed rpm	Max speed rpm
XV-0 / 0,17	0,16	72,3	46,2	75,8	46,2	55,8	26,2	52,3	26,2	220	260	700	9000
XV-0 / 0,25	0,24	72,9	46,5	76,4	46,5	56,4	26,5	52,9	26,5	220	260	700	9000
XV-0 / 0,45	0,45	74,5	47,3	78	47,3	58	27,3	54,5	27,3	220	280	700	9000
XV-0 / 0,57	0,56	75,5	47,8	79	47,8	59	27,8	55,5	27,8	220	280	700	9000
XV-0 / 0,76	0,75	77	48,5	80,5	48,5	60,5	28,5	57	28,5	220	280	700	9000
XV-0 / 0,98	0,92	78,5	49,3	82	49,3	62	29,3	58,5	29,3	220	280	700	6000
XV-0 / 1,27	1,26	81	50,5	84,5	50,5	64,5	30,5	61	30,5	220	280	700	6000
XV-0 / 1,52	1,48	83	51,5	86,5	51,5	66,5	31,5	63	31,5	220	280	700	6000
XV-0 / 2,30	2,28	89	54,5	92,5	54,5	72,5	34,5	69	34,5	220	210	700	5000

MULTIPLE PUMP XV-1

ø 50,8 - FLANGE "SAE AA"

XV-1

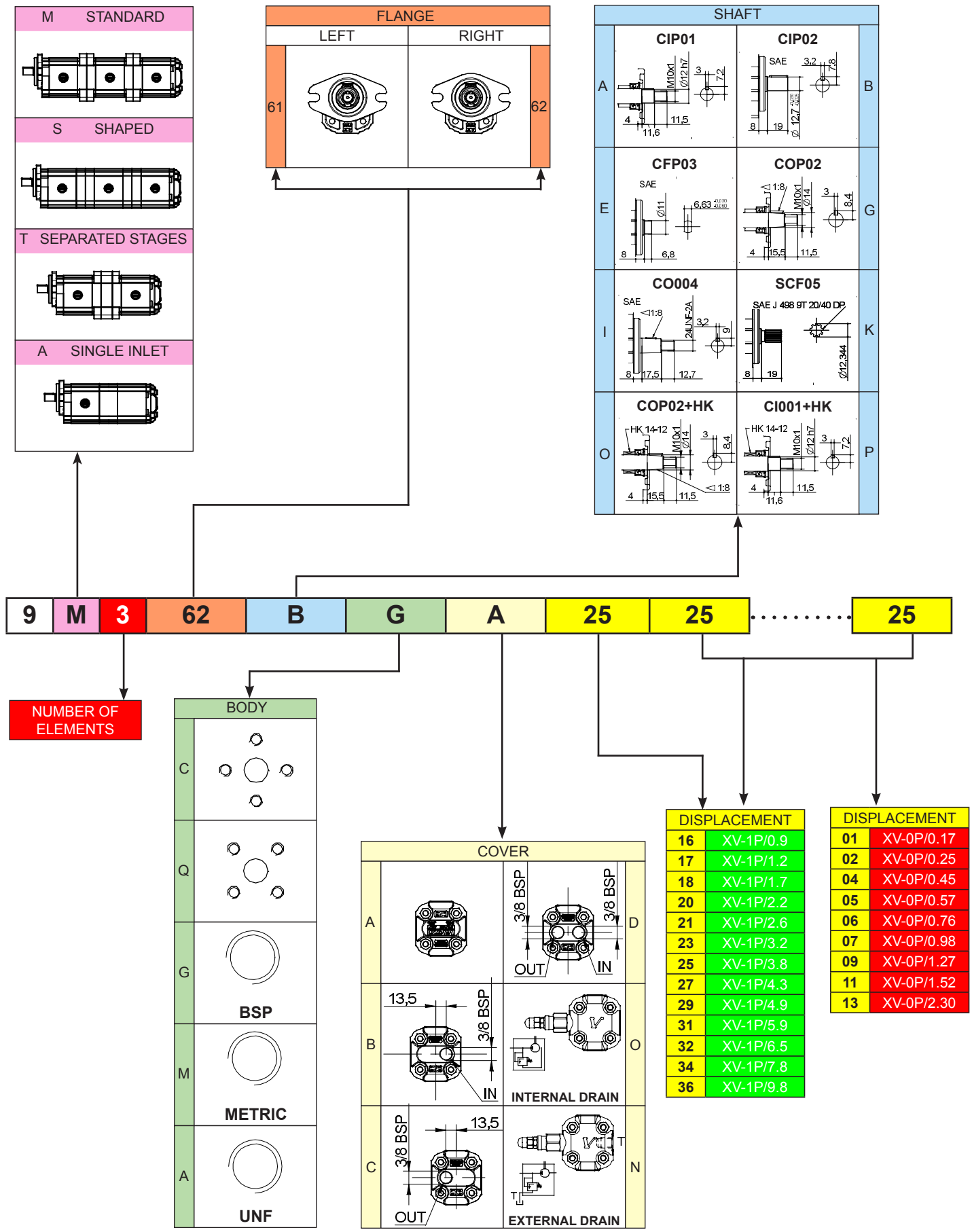

MULTIPLE PUMP XV-1
ø 50,8 - FLANGE "SAE AA"

XV-1

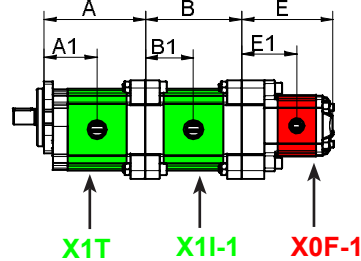
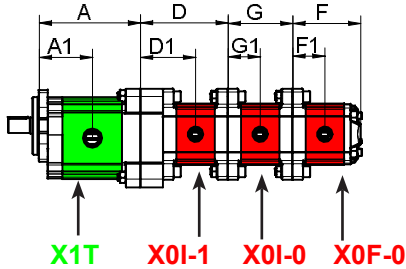
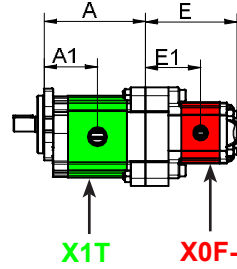
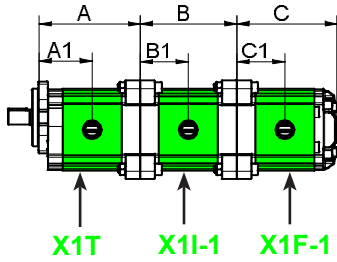
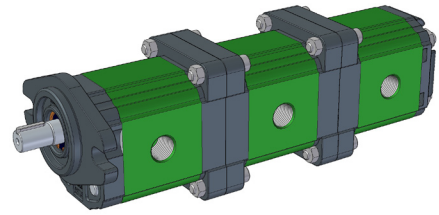
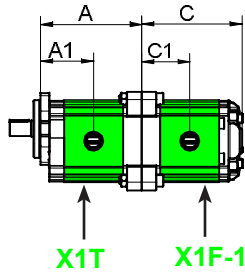
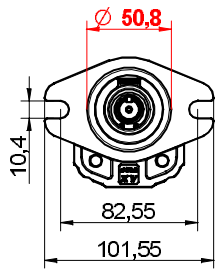

SEPARATED STAGES

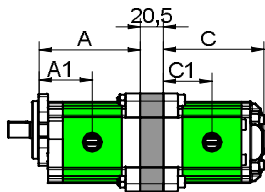

SINGLE INLET

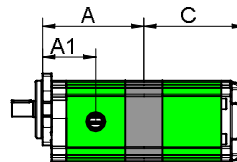

* = SPECIAL ELEMENT, please contact our customer service for details.

TYPE	Displacement cc/rev	A mm	A1 mm	B mm	B1 mm	C mm	C1 mm	P1 bar	P3 bar	Min speed rpm	Max speed rpm
XV-1 / 0,9	0,91	79	41,8	74,5	37,3	78	37,3	240	280	700	6000
XV-1 / 1,2	1,17	80	42,3	75,5	37,8	79	37,8	250	290	700	6000
XV-1 / 1,7	1,56	81,5	43	77	38,5	80,5	38,5	250	290	700	6000
XV-1 / 2,2	2,08	83,5	44	79	39,5	82,5	39,5	250	290	700	6000
XV-1 / 2,6	2,60	85,5	45	81	40,5	84,5	40,5	250	300	700	6000
XV-1 / 3,2	3,12	87,5	46	83	41,5	86	41,5	250	300	700	6000
XV-1 / 3,8	3,64	89,5	47	85	42,5	88,5	42,5	250	300	700	6000
XV-1 / 4,3	4,26	91,5	48	87	43,5	90,5	43,5	250	300	700	6000
XV-1 / 4,9	4,94	94,5	49,5	90	45	93,5	45	250	300	700	6000
XV-1 / 5,9	5,85	98	51,3	93,5	46,8	97	46,8	250	300	700	5000
XV-1 / 6,5	6,50	100,5	52,5	96	48	99,5	48	250	300	700	5000
XV-1 / 7,8	7,54	104,5	54,5	100	50	103,5	50	220	260	700	5000
XV-1 / 9,8	9,88	113,5	59	109	54,5	112,5	54,5	190	230	700	4000

TYPE	Displacement cc/rev	D mm	D1 mm	E mm	E1 mm	F mm	F1 mm	G mm	G1 mm	P1 bar	P3 bar	Min speed rpm	Max speed rpm
XV-0 / 0,17	0,16	72,3	46,2	75,8	46,2	55,8	26,2	52,3	26,2	220	260	700	9000
XV-0 / 0,25	0,24	72,9	46,5	76,4	46,5	56,4	26,5	52,9	26,5	220	260	700	9000
XV-0 / 0,45	0,45	74,5	47,3	78	47,3	58	27,3	54,5	27,3	220	280	700	9000
XV-0 / 0,57	0,56	75,5	47,8	79	47,8	59	27,8	55,5	27,8	220	280	700	9000
XV-0 / 0,76	0,75	77	48,5	80,5	48,5	60,5	28,5	57	28,5	220	280	700	9000
XV-0 / 0,98	0,92	78,5	49,3	82	49,3	62	29,3	58,5	29,3	220	280	700	6000
XV-0 / 1,27	1,26	81	50,5	84,5	50,5	64,5	30,5	61	30,5	220	280	700	6000
XV-0 / 1,52	1,48	83	51,5	86,5	51,5	66,5	31,5	63	31,5	220	280	700	6000
XV-0 / 2,30	2,28	89	54,5	92,5	54,5	72,5	34,5	69	34,5	220	210	700	5000

MULTIPLE PUMP XV-2

Ø 36,5 FLANGE

XV-2

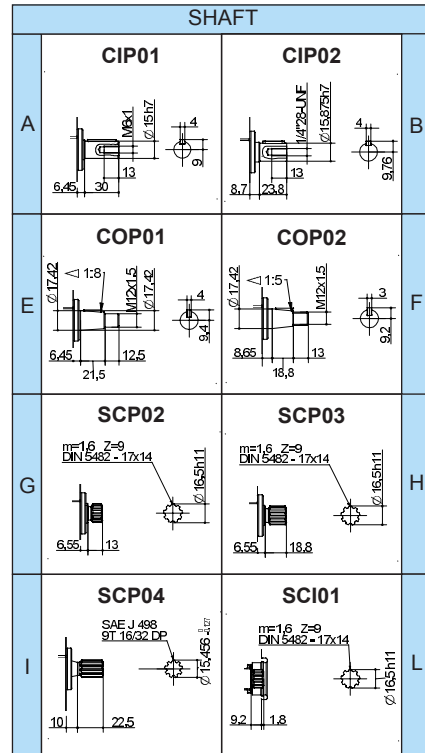
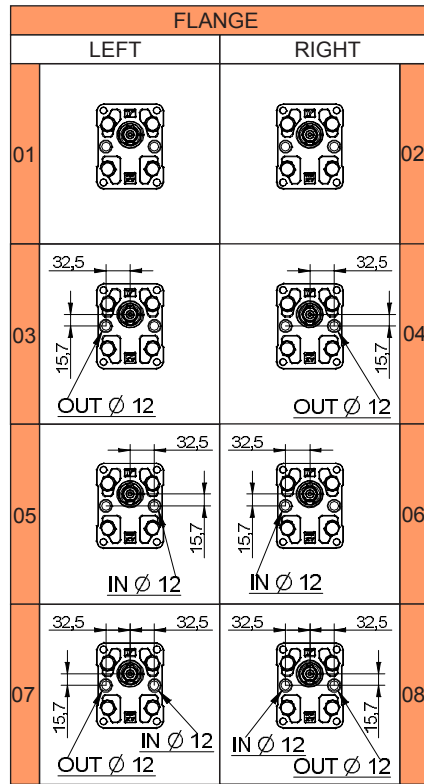
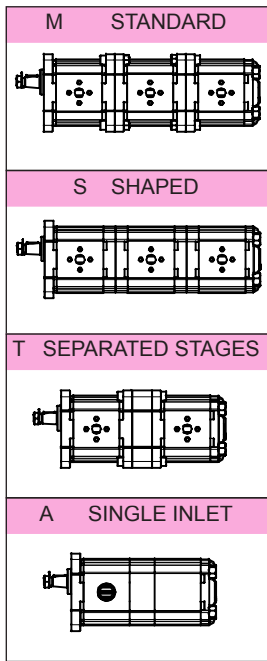

9 M 3 02 E C A 51 51 51

NUMBER OF ELEMENTS

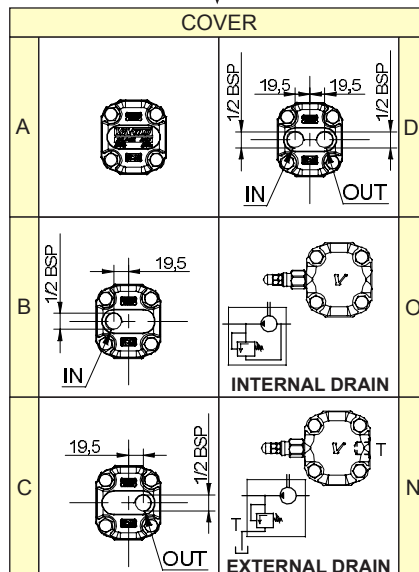
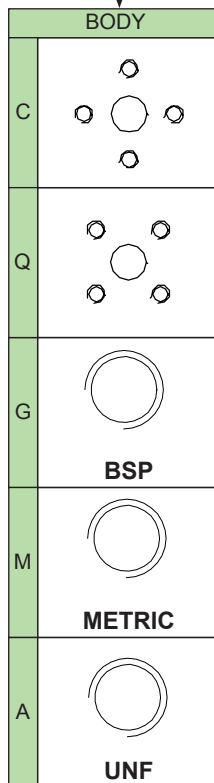

DISPLACEMENT	
41	XV-2P/ 4
43	XV-2P/ 6
45	XV-2P/ 9
47	XV-2P/ 11
49	XV-2P/14
51	XV-2P/17
53	XV-2P/19
55	XV-2P/22
57	XV-2P/26
59	XV-2P/30
61	XV-2P/34
63	XV-2P/40

DISPLACEMENT	
01	XV-0P/0.17
02	XV-0P/0.25
04	XV-0P/0.45
05	XV-0P/0.57
06	XV-0P/0.76
07	XV-0P/0.98
09	XV-0P/1.27
11	XV-0P/1.52
13	XV-0P/2.30
16	XV-1P/0.9
17	XV-1P/1.2
18	XV-1P/1.7
20	XV-1P/2.2
21	XV-1P/2.6
23	XV-1P/3.2
25	XV-1P/3.8
27	XV-1P/4.3
29	XV-1P/4.9
31	XV-1P/5.9
32	XV-1P/6.5
34	XV-1P/7.8
36	XV-1P/9.8

MULTIPLE PUMP XV-2

Ø 36,5 FLANGE

XV-2

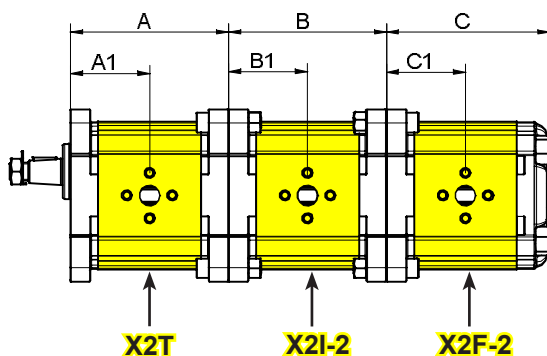
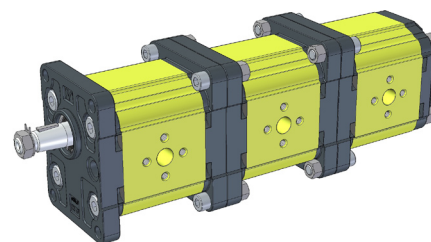
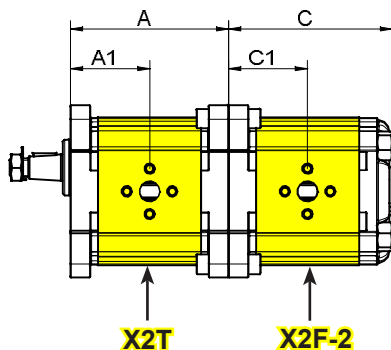
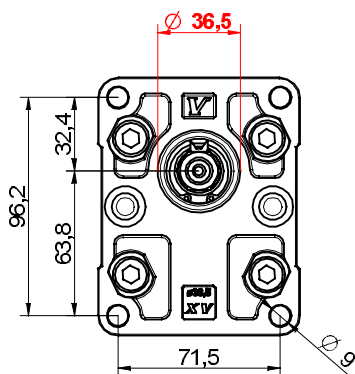

SEPARATED STAGES

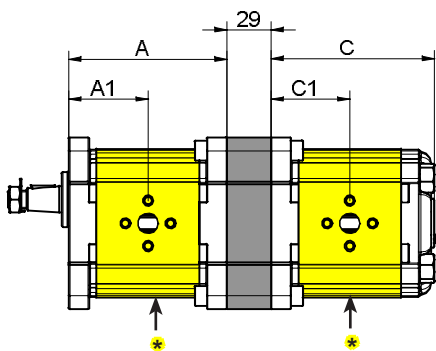

SINGLE INLET

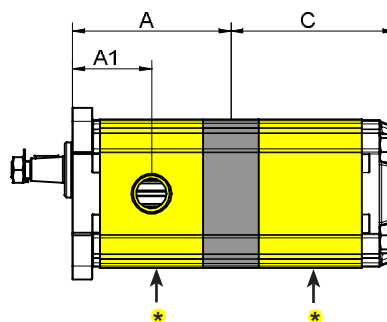

* = SPECIAL ELEMENT, please contact our customer service for details.

TYPE	Displacement cc/rev	A mm	A1 mm	B mm	B1 mm	C mm	C1 mm	P1 bar	P3 bar	Min speed rpm	Max speed rpm
XV-2 / 4	4,20	83,4	41,7	83,4	41,7	87,2	41,7	260	300	700	4000
XV-2 / 6	6,00	86,4	43,2	86,4	43,2	90,2	43,2	260	300	700	3500
XV-2 / 9	8,40	90,4	45,2	90,4	45,2	94,2	45,2	260	300	700	3500
XV-2 / 11	10,80	94,4	47,2	94,4	47,2	98,2	47,2	260	300	700	3500
XV-2 / 14	14,40	100,4	50,2	100,4	50,2	104,2	50,2	250	290	700	3500
XV-2 / 17	16,80	104,4	52,2	104,4	52,2	108,2	52,2	230	270	700	3500
XV-2 / 19	19,20	108,4	54,2	108,4	54,2	112,2	54,2	210	250	700	3000
XV-2 / 22	22,80	114,4	57,2	114,4	57,2	118,2	57,2	200	240	700	3000
XV-2 / 26	26,20	118,4	59,2	118,4	59,2	122,2	59,2	170	210	700	3000
XV-2 / 30	30,00	126,4	63,2	126,4	63,2	130,2	63,2	160	200	700	2500
XV-2 / 34	34,20	133,4	66,7	133,4	66,7	137,2	66,7	150	190	700	2500
XV-2 / 40	39,60	142,4	71,2	142,4	71,2	146,2	71,2	140	180	700	2000

MULTIPLE PUMP XV-2

Ø 36,5 FLANGE

XV-2

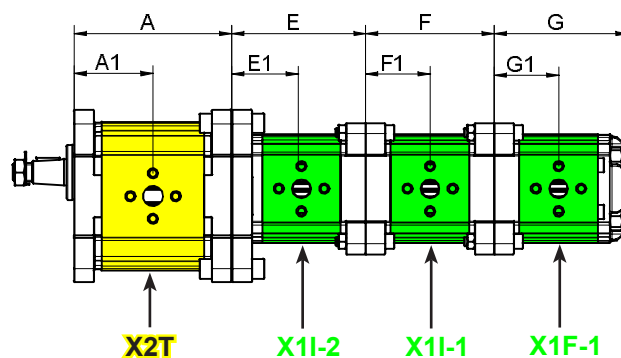
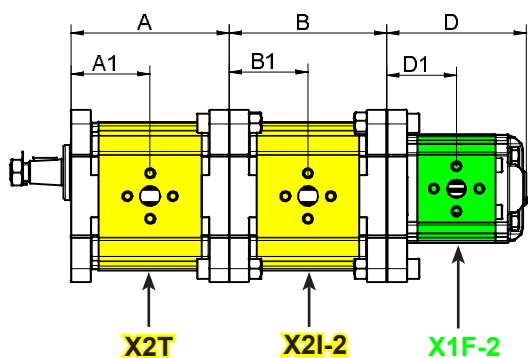
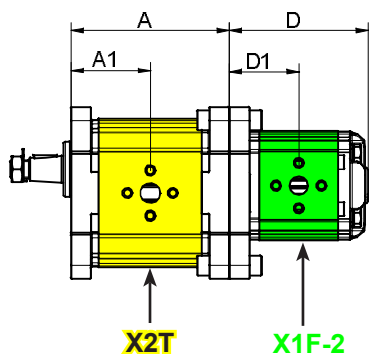
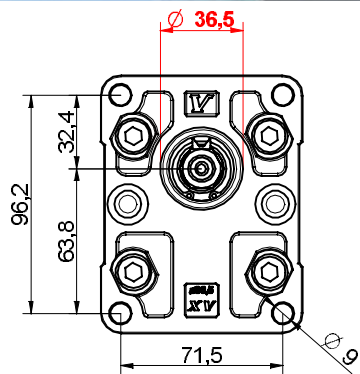

SEPARATED STAGES

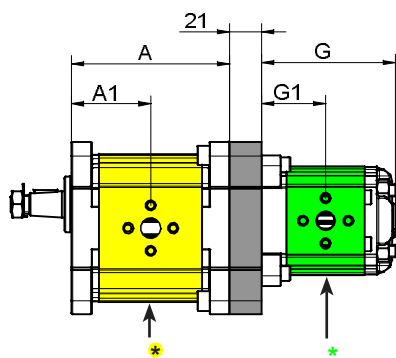

* = SPECIAL ELEMENT, please contact our customer service for details.

TYPE	Displacement cc/rev	A mm	A1 mm	B mm	B1 mm	C mm	C1 mm	P1 bar	P3 bar	Min speed rpm	Max speed rpm
XV-2 / 4	4,20	83,4	41,7	83,4	41,7	87,2	41,7	260	300	700	4000
XV-2 / 6	6,00	86,4	43,2	86,4	43,2	90,2	43,2	260	300	700	3500
XV-2 / 9	8,40	90,4	45,2	90,4	45,2	94,2	45,2	260	300	700	3500
XV-2 / 11	10,80	94,4	47,2	94,4	47,2	98,2	47,2	260	300	700	3500
XV-2 / 14	14,40	100,4	50,2	100,4	50,2	104,2	50,2	250	290	700	3500
XV-2 / 17	16,80	104,4	52,2	104,4	52,2	108,2	52,2	230	270	700	3500
XV-2 / 19	19,20	108,4	54,2	108,4	54,2	112,2	54,2	210	250	700	3000
XV-2 / 22	22,80	114,4	57,2	114,4	57,2	118,2	57,2	200	240	700	3000
XV-2 / 26	26,20	118,4	59,2	118,4	59,2	122,2	59,2	170	210	700	3000
XV-2 / 30	30,00	126,4	63,2	126,4	63,2	130,2	63,2	160	200	700	2500
XV-2 / 34	34,20	133,4	66,7	133,4	66,7	137,2	66,7	150	190	700	2500
XV-2 / 40	39,60	142,4	71,2	142,4	71,2	146,2	71,2	140	180	700	2000

MULTIPLE PUMP XV-2

ø 36,5 FLANGE

XV-2

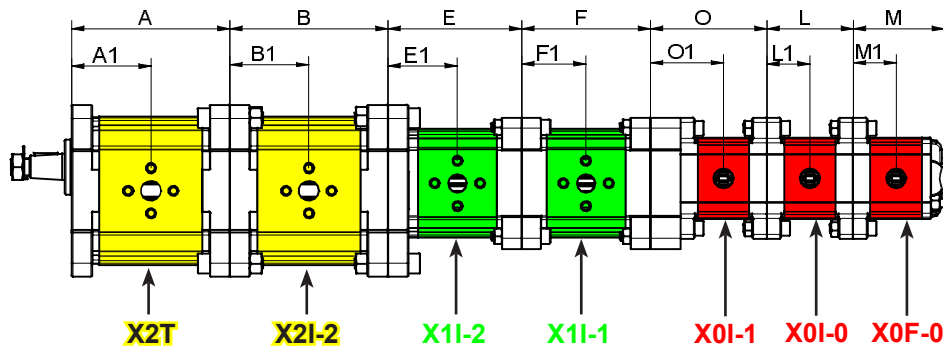
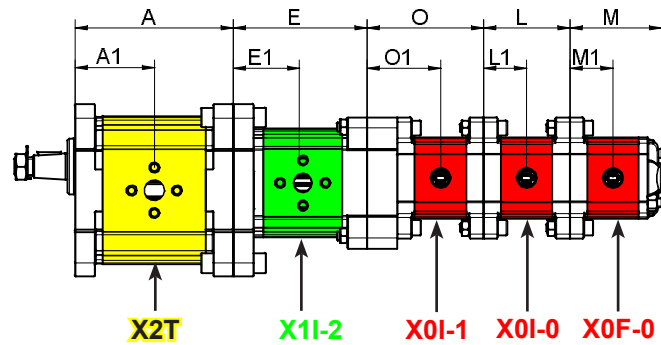
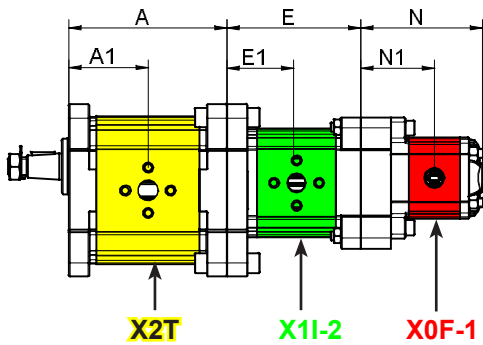
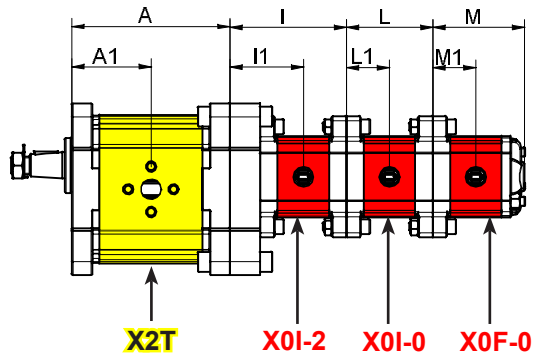
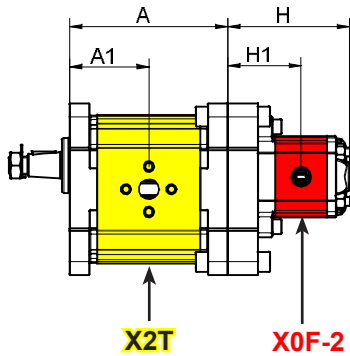

TYPE	Displacement cc/rev	D mm	D1 mm	E mm	E1 mm	F mm	F1 mm	G mm	G1 mm	P1 bar	P3 bar	Min speed rpm	Max speed rpm
XV-1 / 0,9	0,91	81,5	40,8	78	40,8	74,5	37,3	78	37,3	240	280	700	6000
XV-1 / 1,2	1,17	82,5	41,3	79	41,3	75,5	37,8	79	37,8	250	290	700	6000
XV-1 / 1,7	1,56	84	42	80,5	42	77	38,5	80,5	38,5	250	290	700	6000
XV-1 / 2,2	2,08	86	43	82,5	43	79	39,5	82,5	39,5	250	290	700	6000
XV-1 / 2,6	2,60	88	44	84,5	44	81	40,5	84,5	40,5	250	300	700	6000
XV-1 / 3,2	3,12	90	45	86	45	83	41,5	86	41,5	250	300	700	6000
XV-1 / 3,8	3,64	92	46	88,5	46	85	42,5	88,5	42,5	250	300	700	6000
XV-1 / 4,3	4,26	94	47	90,5	47	87	43,5	90,5	43,5	250	300	700	6000
XV-1 / 4,9	4,94	97	48,5	93,5	48,5	90	45	93,5	45	250	300	700	6000
XV-1 / 5,9	5,85	100,5	50,3	97	50,3	93,5	46,8	97	46,8	250	300	700	5000
XV-1 / 6,5	6,50	103	51,5	99,5	51,5	96	48	99,5	48	250	300	700	5000
XV-1 / 7,8	7,54	107	53,5	103,5	53,5	100	50	103,5	50	220	260	700	5000
XV-1 / 9,8	9,88	116	58	112,5	58	109	54,5	112,5	54,5	190	230	700	4000

TYPE	Displacem. cc/rev	H mm	H1 mm	I mm	I1 mm	L mm	L1 mm	M mm	M1 mm	N mm	N1 mm	O mm	O1 mm	P1 bar	P3 bar	Min speed rpm	Max speed rpm
XV-0 / 0,17	0,16	75,8	46,2	72,3	46,2	52,3	26,2	55,8	26,2	75,8	46,2	72,3	46,2	220	260	700	9000
XV-0 / 0,25	0,24	76,4	46,5	72,9	46,5	52,9	26,5	56,4	26,5	76,4	46,5	72,9	46,5	220	260	700	9000
XV-0 / 0,45	0,45	78	47,3	74,5	47,3	54,5	27,3	58	27,3	78	47,3	74,5	47,3	220	280	700	9000
XV-0 / 0,57	0,56	79	47,8	75,5	47,8	55,5	27,8	59	27,8	79	47,8	75,5	47,8	220	280	700	9000
XV-0 / 0,76	0,75	80,5	48,5	77	48,5	57	28,5	60,5	28,5	80,5	48,5	77	48,5	220	280	700	9000
XV-0 / 0,98	0,92	82	49,3	78,5	49,3	58,5	29,3	62	29,3	82	49,3	78,5	49,3	220	280	700	6000
XV-0 / 1,27	1,26	84,5	50,5	81	50,5	61	30,5	64,5	30,5	84,5	50,5	81	50,5	220	280	700	6000
XV-0 / 1,52	1,48	86,5	51,5	83	51,5	63	31,5	66,5	31,5	86,5	51,5	83	51,5	220	280	700	6000
XV-0 / 2,30	2,28	92,5	54,5	89	54,5	69	34,5	72,5	34,5	92,5	54,5	89	54,5	220	210	700	5000

MULTIPLE PUMP XV-2

ø 50 "BH" Body-Shaped FLANGE

XV-2

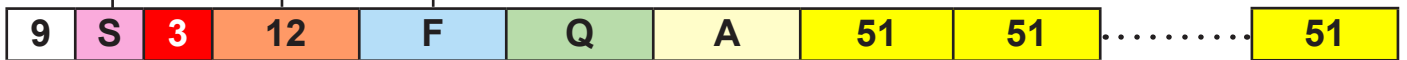
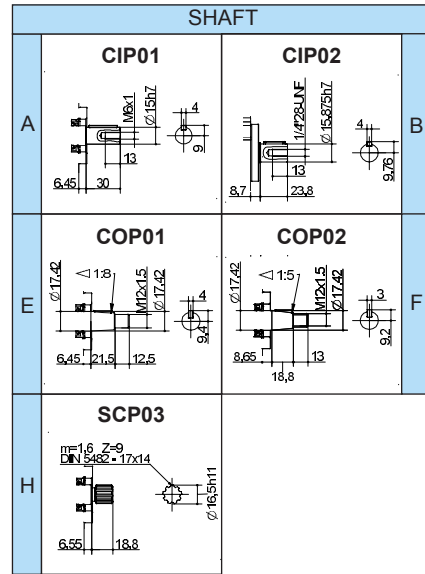
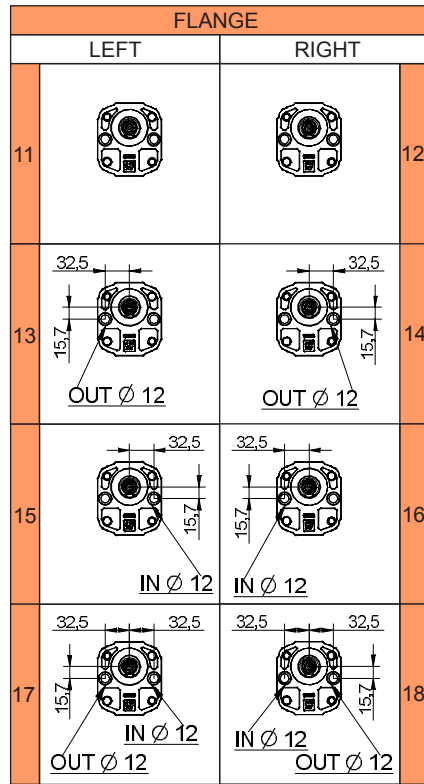
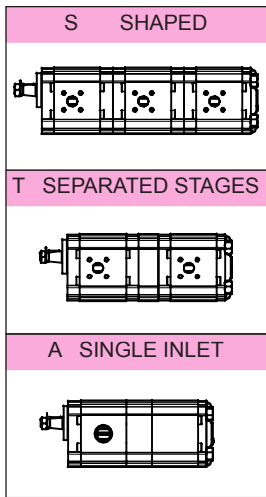

NUMBER OF ELEMENTS

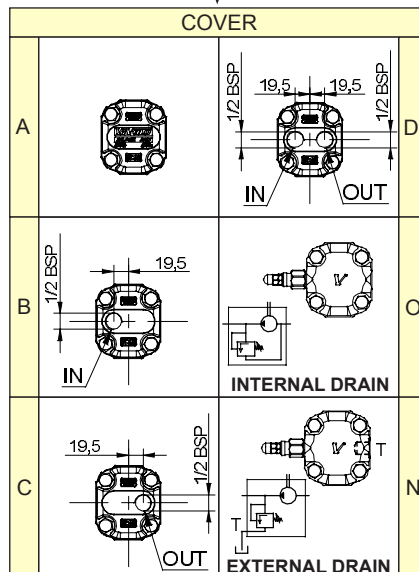
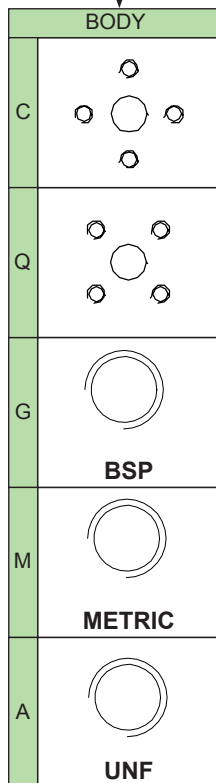

DISPLACEMENT	
41	XV-2P/ 4
43	XV-2P/ 6
45	XV-2P/ 9
47	XV-2P/ 11
49	XV-2P/14
51	XV-2P/17
53	XV-2P/19
55	XV-2P/22
57	XV-2P/26
59	XV-2P/30
61	XV-2P/34
63	XV-2P/40

DISPLACEMENT	
01	XV-0P/0.17
02	XV-0P/0.25
04	XV-0P/0.45
05	XV-0P/0.57
06	XV-0P/0.76
07	XV-0P/0.98
09	XV-0P/1.27
11	XV-0P/1.52
13	XV-0P/2.30
16	XV-1P/0.9
17	XV-1P/1.2
18	XV-1P/1.7
20	XV-1P/2.2
21	XV-1P/2.6
23	XV-1P/3.2
25	XV-1P/3.8
27	XV-1P/4.3
29	XV-1P/4.9
31	XV-1P/5.9
32	XV-1P/6.5
34	XV-1P/7.8
36	XV-1P/9.8

MULTIPLE PUMP XV-2

ø 50 "BH" Body-Shaped FLANGE

XV-2

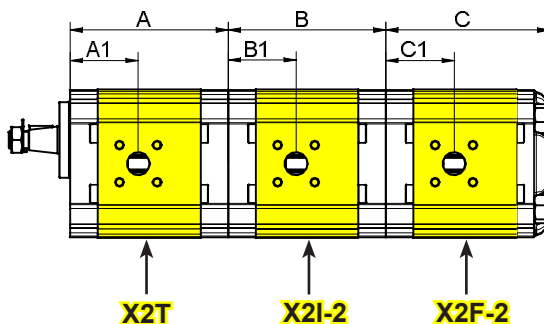
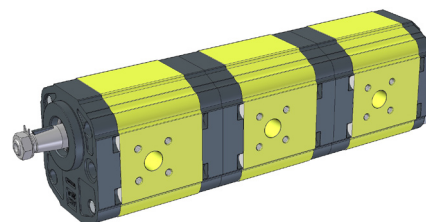
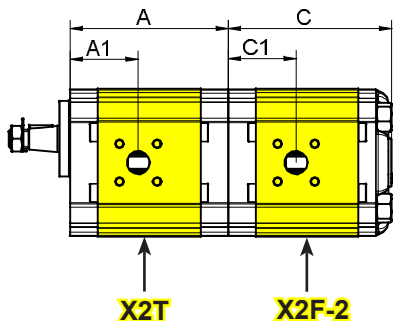
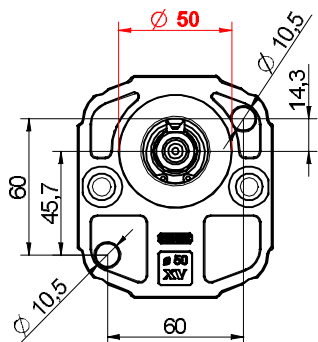

SEPARATED STAGES

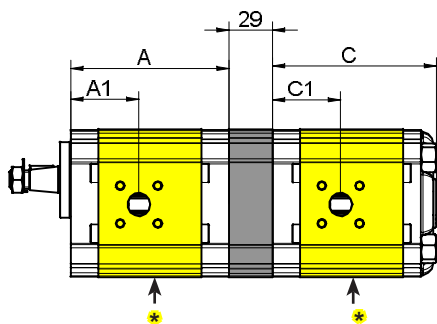

SINGLE INLET

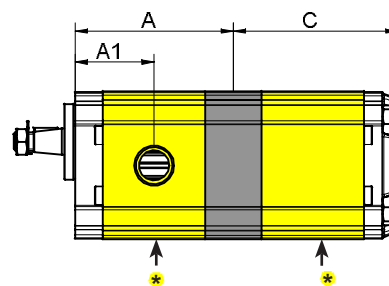

* = SPECIAL ELEMENT, please contact our customer service for details.

TYPE	Displacement cc/rev	A mm	A1 mm	B mm	B1 mm	C mm	C1 mm	P1 bar	P3 bar	Min speed rpm	Max speed rpm
XV-2 / 4	4,20	83,4	38,6	83,4	38,6	87,2	38,6	260	300	700	4000
XV-2 / 6	6,00	86,4	38,6	86,4	38,6	90,2	38,6	260	300	700	3500
XV-2 / 9	8,40	90,4	40,6	90,4	40,6	94,2	40,6	260	300	700	3500
XV-2 / 11	10,80	94,4	45	94,4	45	98,2	45	260	300	700	3500
XV-2 / 14	14,40	100,4	45	100,4	45	104,2	45	250	290	700	3500
XV-2 / 17	16,80	104,4	45	104,4	45	108,2	45	230	270	700	3500
XV-2 / 19	19,20	108,4	45	108,4	45	112,2	45	210	250	700	3000
XV-2 / 22	22,80	114,4	52,5	114,4	52,5	118,2	52,5	200	240	700	3000
XV-2 / 26	26,20	118,4	52,5	118,4	52,5	122,2	52,5	170	210	700	3000
XV-2 / 30	30,00	126,4	60,7	126,4	60,7	130,2	60,7	160	200	700	2500
XV-2 / 34	34,20	133,4	60,7	133,4	60,7	137,2	60,7	150	190	700	2500
XV-2 / 40	39,60	142,4	60,7	142,4	60,7	146,2	60,7	140	180	700	2000

MULTIPLE PUMP XV-2

Ø 50 "BH" Body-Shaped FLANGE

XV-2

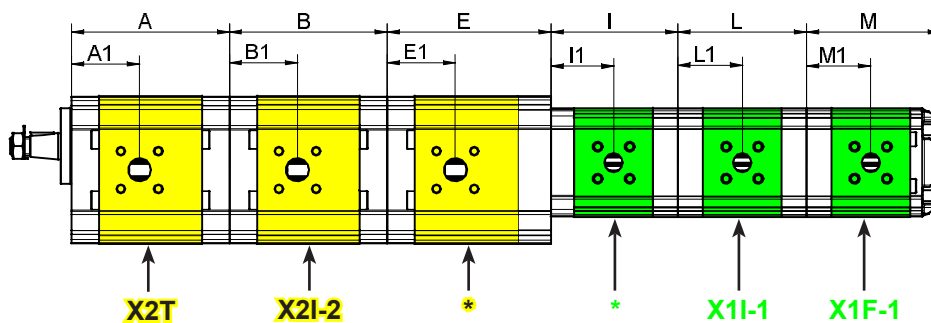
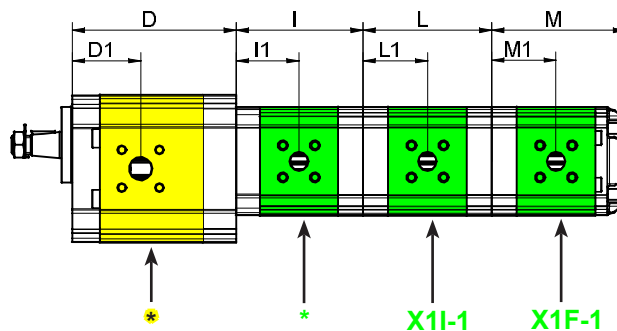
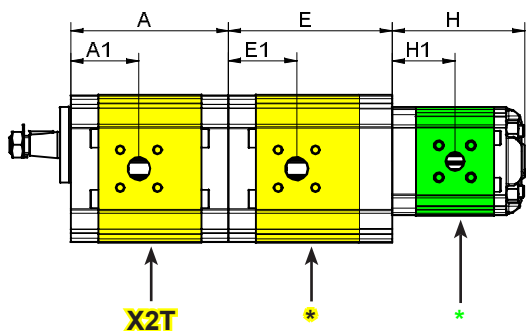
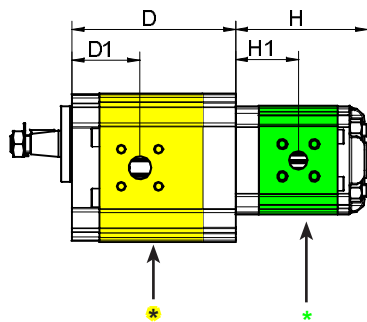
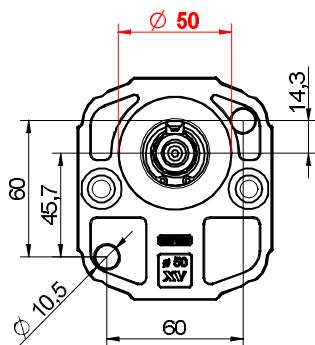

* = SPECIAL ELEMENT, please contact our customer service for details.

TYPE	Displacem cc/rev	A mm	A1 mm	B mm	B1 mm	C mm	C1 mm	D mm	D1 mm	E mm	E1 mm	F mm	F1 mm	G mm	G1 mm	P1 bar	P3 bar	Min speed rpm	Max speed rpm
XV-2 / 4	4,20	83,4	38,6	83,4	38,6	87,2	38,6	87,2	41,7	87,2	41,7	103,2	41,7	103,2	41,7	260	300	700	4000
XV-2 / 6	6,00	86,4	38,6	86,4	38,6	90,2	38,6	90,2	43,2	90,2	43,2	106,2	43,2	106,2	43,2	260	300	700	3500
XV-2 / 9	8,40	90,4	40,6	90,4	40,6	94,2	40,6	94,2	45,2	94,2	45,2	110,2	45,2	110,2	45,2	260	300	700	3500
XV-2 / 11	10,80	94,4	45	94,4	45	98,2	45	98,2	47,2	98,2	47,2	114,2	47,2	114,2	47,2	260	300	700	3500
XV-2 / 14	14,40	100,4	45	100,4	45	104,2	45	104,2	50,2	104,2	50,2	120,2	50,2	120,2	50,2	250	290	700	3500
XV-2 / 17	16,80	104,4	45	104,4	45	108,2	45	108,2	52,2	108,2	52,2	124,2	52,2	124,2	52,2	230	270	700	3500
XV-2 / 19	19,20	108,4	45	108,4	45	112,2	45	112,2	54,2	112,2	54,2	128,2	54,2	128,2	54,2	210	250	700	3000
XV-2 / 22	22,80	114,4	52,5	114,4	52,5	118,2	52,5	118,2	57,2	118,2	57,2	134,2	57,2	134,2	57,2	200	240	700	3000
XV-2 / 26	26,20	118,4	52,5	118,4	52,5	122,2	52,5	122,2	59,2	122,2	59,2	138,2	59,2	138,2	59,2	170	210	700	3000
XV-2 / 30	30,00	126,4	60,7	126,4	60,7	130,2	60,7	130,2	63,2	130,2	63,2	146,2	63,2	146,2	63,2	160	200	700	2500
XV-2 / 34	34,20	133,4	60,7	133,4	60,7	137,2	60,7	137,2	66,7	137,2	66,7	153,2	66,7	153,2	66,7	150	190	700	2500
XV-2 / 40	39,60	142,4	60,7	142,4	60,7	146,2	60,7	146,2	71,2	146,2	71,2	162,2	71,2	162,2	71,2	140	180	700	2000

MULTIPLE PUMP XV-2

ø 50 "BH" Body-Shaped FLANGE

XV-2

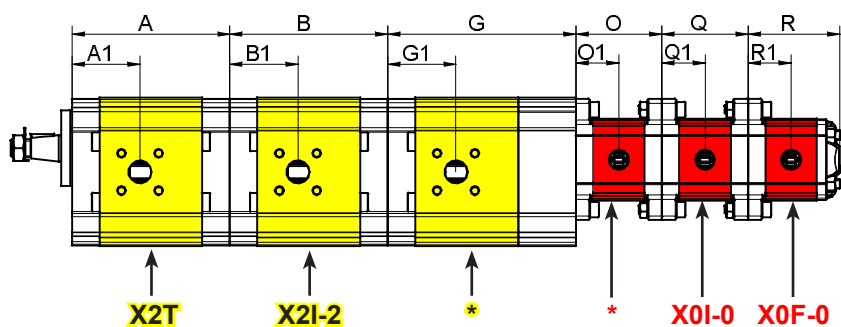
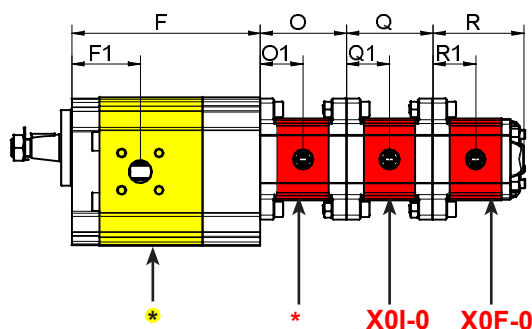
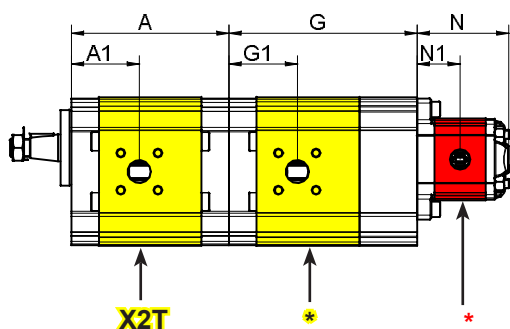
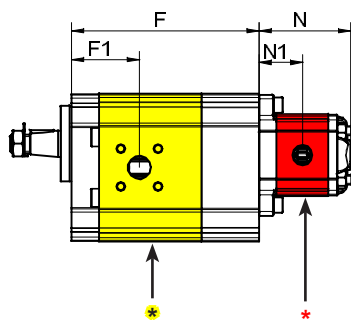

TYPE	Displacement cc/rev	H mm	H1 mm	I mm	I1 mm	L mm	L1 mm	M mm	M1 mm	P1 bar	P3 bar	Min speed rpm	Max speed rpm
XV-1 / 0,9	0,91	77	36,3	73,5	36,3	74,5	37,3	78	37,3	240	280	700	6000
XV-1 / 1,2	1,17	78	36,8	74,5	36,8	75,5	37,8	79	37,8	250	290	700	6000
XV-1 / 1,7	1,56	79,5	37,5	76	37,5	77	38,5	80,5	38,5	250	290	700	6000
XV-1 / 2,2	2,08	81,5	38,5	78	38,5	79	39,5	82,5	39,5	250	290	700	6000
XV-1 / 2,6	2,60	83,5	39,5	80	39,5	81	40,5	84,5	40,5	250	300	700	6000
XV-1 / 3,2	3,12	85,5	40,5	82	40,5	83	41,5	86	41,5	250	300	700	6000
XV-1 / 3,8	3,64	87,5	41,5	84	41,5	85	42,5	88,5	42,5	250	300	700	6000
XV-1 / 4,3	4,26	89,5	42,5	86	42,5	87	43,5	90,5	43,5	250	300	700	6000
XV-1 / 4,9	4,94	92,5	44	89	44	90	45	93,5	45	250	300	700	6000
XV-1 / 5,9	5,85	96	45,8	92,5	45,8	93,5	46,8	97	46,8	250	300	700	5000
XV-1 / 6,5	6,50	98,5	47	95	47	96	48	99,5	48	250	300	700	5000
XV-1 / 7,8	7,54	102,5	49	99	49	100	50	103,5	50	220	260	700	5000
XV-1 / 9,8	9,88	111,5	53,5	108	53,5	109	54,5	112,5	54,5	190	230	700	4000

TYPE	Displacem. cc/rev	N mm	N1 mm	O mm	O1 mm	Q mm	Q1 mm	R mm	R1 mm	P1 bar	P3 bar	Min speed rpm	Max speed rpm
XV-0 / 0,17	0,16	55,8	26,2	52,3	26,2	52,3	26,2	55,8	26,2	220	260	700	9000
XV-0 / 0,25	0,24	56,4	26,5	52,9	26,5	52,9	26,5	56,4	26,5	220	260	700	9000
XV-0 / 0,45	0,45	58	27,3	54,5	27,3	54,5	27,3	58	27,3	220	280	700	9000
XV-0 / 0,57	0,56	59	27,8	55,5	27,8	55,5	27,8	59	27,8	220	280	700	9000
XV-0 / 0,76	0,75	60,5	28,5	57	28,5	57	28,5	60,5	28,5	220	280	700	9000
XV-0 / 0,98	0,92	62	29,3	58,5	29,3	58,5	29,3	62	29,3	220	280	700	6000
XV-0 / 1,27	1,26	64,5	30,5	61	30,5	61	30,5	64,5	30,5	220	280	700	6000
XV-0 / 1,52	1,48	66,5	31,5	63	31,5	63	31,5	66,5	31,5	220	280	700	6000
XV-0 / 2,30	2,28	72,5	34,5	69	34,5	69	34,5	72,5	34,5	220	210	700	5000

MULTIPLE PUMP XV-2

ø 50 "BH" Body-Shaped FLANGE

XV-2

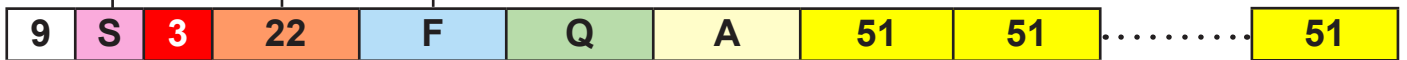
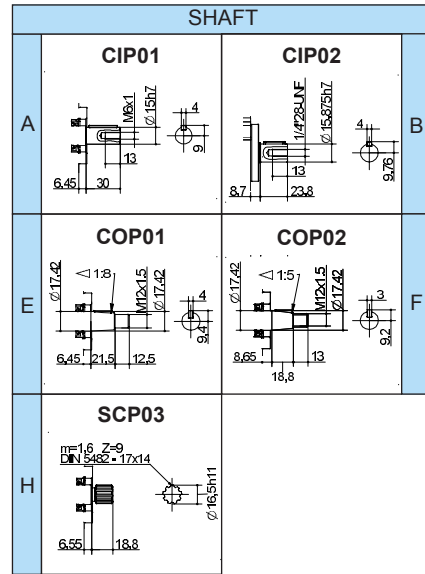
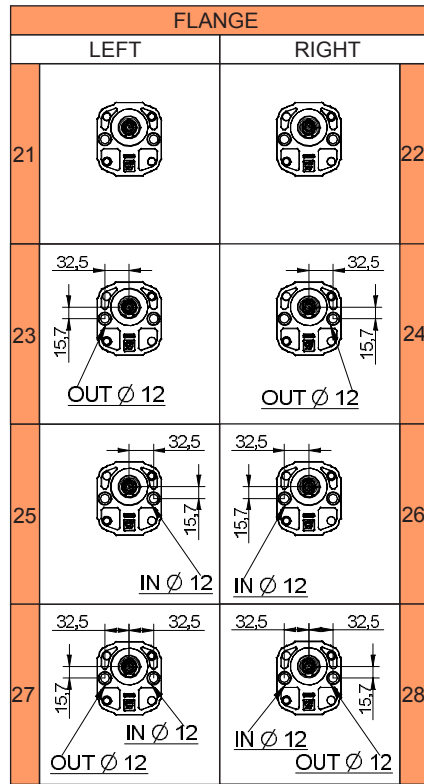
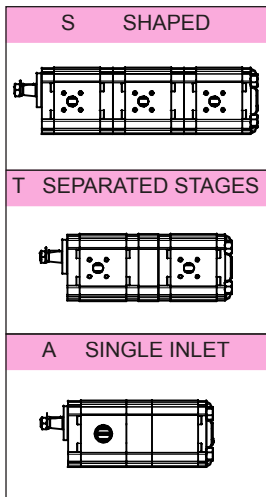

NUMBER OF ELEMENTS

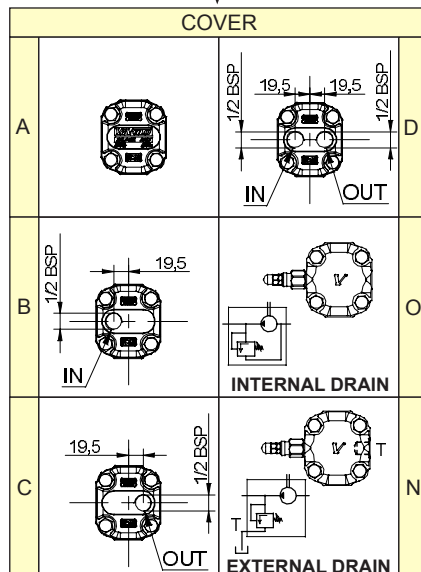
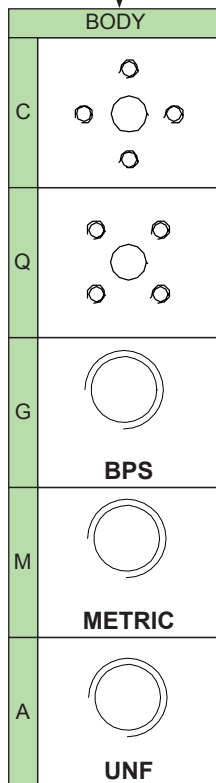

DISPLACEMENT	
41	XV-2P/ 4
43	XV-2P/ 6
45	XV-2P/ 9
47	XV-2P/ 11
49	XV-2P/14
51	XV-2P/17
53	XV-2P/19
55	XV-2P/22
57	XV-2P/26
59	XV-2P/30
61	XV-2P/34
63	XV-2P/40

DISPLACEMENT	
01	XV-0P/0.17
02	XV-0P/0.25
04	XV-0P/0.45
05	XV-0P/0.57
06	XV-0P/0.76
07	XV-0P/0.98
09	XV-0P/1.27
11	XV-0P/1.52
13	XV-0P/2.30
16	XV-1P/0.9
17	XV-1P/1.2
18	XV-1P/1.7
20	XV-1P/2.2
21	XV-1P/2.6
23	XV-1P/3.2
25	XV-1P/3.8
27	XV-1P/4.3
29	XV-1P/4.9
31	XV-1P/5.9
32	XV-1P/6.5
34	XV-1P/7.8
36	XV-1P/9.8

MULTIPLE PUMP XV-2

ø 50 "HY" Body-Shaped FLANGE

XV-2

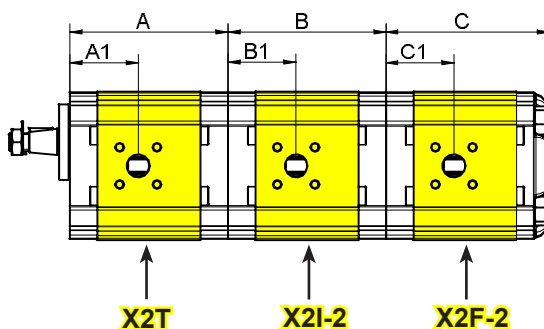
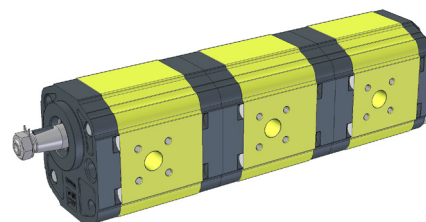
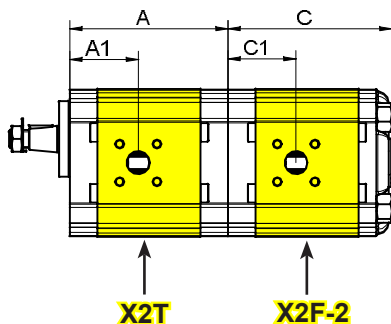
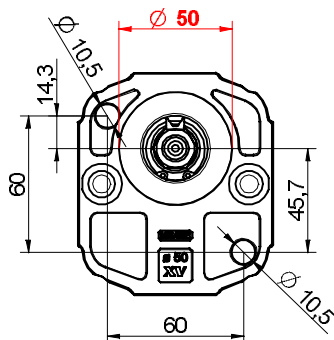

SEPARATED STAGES

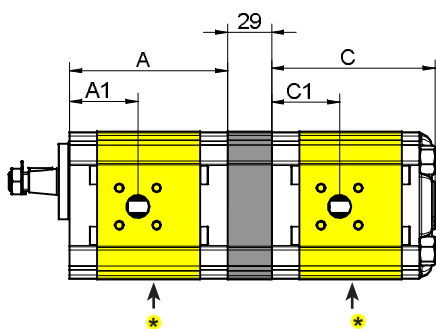

SINGLE INLET

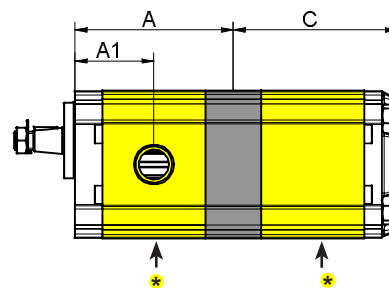

* = SPECIAL ELEMENT, please contact our customer service for details.

TYPE	Displacement cc/rev	A mm	A1 mm	B mm	B1 mm	C mm	C1 mm	P1 bar	P3 bar	Min speed rpm	Max speed rpm
XV-2 / 4	4,20	83,4	38,6	83,4	38,6	87,2	38,6	260	300	700	4000
XV-2 / 6	6,00	86,4	38,6	86,4	38,6	90,2	38,6	260	300	700	3500
XV-2 / 9	8,40	90,4	40,6	90,4	40,6	94,2	40,6	260	300	700	3500
XV-2 / 11	10,80	94,4	45	94,4	45	98,2	45	260	300	700	3500
XV-2 / 14	14,40	100,4	45	100,4	45	104,2	45	250	290	700	3500
XV-2 / 17	16,80	104,4	45	104,4	45	108,2	45	230	270	700	3500
XV-2 / 19	19,20	108,4	45	108,4	45	112,2	45	210	250	700	3000
XV-2 / 22	22,80	114,4	52,5	114,4	52,5	118,2	52,5	200	240	700	3000
XV-2 / 26	26,20	118,4	52,5	118,4	52,5	122,2	52,5	170	210	700	3000
XV-2 / 30	30,00	126,4	60,7	126,4	60,7	130,2	60,7	160	200	700	2500
XV-2 / 34	34,20	133,4	60,7	133,4	60,7	137,2	60,7	150	190	700	2500
XV-2 / 40	39,60	142,4	60,7	142,4	60,7	146,2	60,7	140	180	700	2000

MULTIPLE PUMP XV-2

Ø 50 "HY" Body-Shaped FLANGE

XV-2

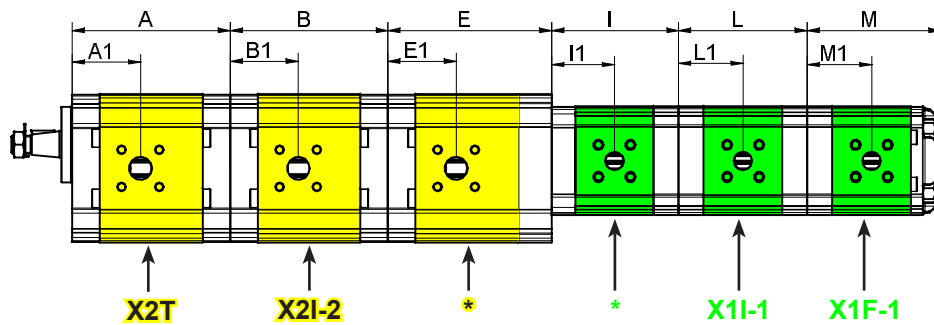
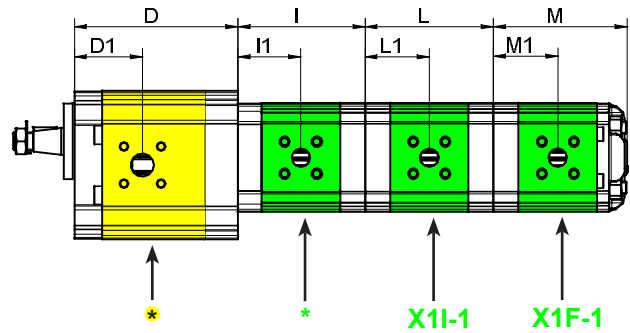
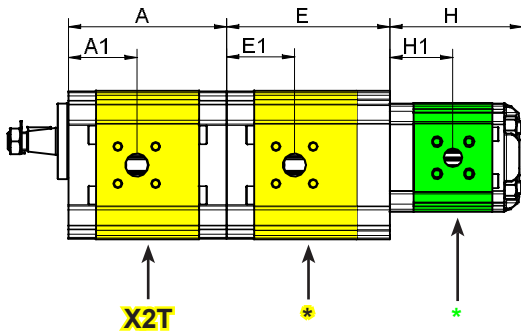
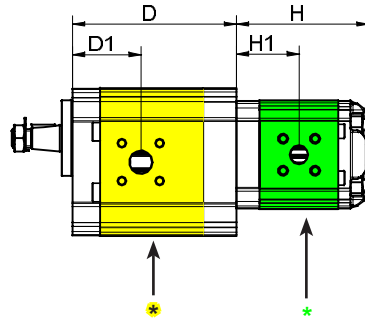
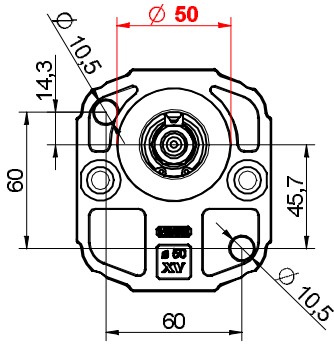

* = SPECIAL ELEMENT, please contact our customer service for details.

TYPE	Displacem cc/rev	A mm	A1 mm	B mm	B1 mm	C mm	C1 mm	D mm	D1 mm	E mm	E1 mm	F mm	F1 mm	G mm	G1 mm	P1 bar	P3 bar	Min speed rpm	Max speed rpm
XV-2 / 4	4,20	83,4	38,6	83,4	38,6	87,2	38,6	87,2	41,7	87,2	41,7	103,2	41,7	103,2	41,7	260	300	700	4000
XV-2 / 6	6,00	86,4	38,6	86,4	38,6	90,2	38,6	90,2	43,2	90,2	43,2	106,2	43,2	106,2	43,2	260	300	700	3500
XV-2 / 9	8,40	90,4	40,6	90,4	40,6	94,2	40,6	94,2	45,2	94,2	45,2	110,2	45,2	110,2	45,2	260	300	700	3500
XV-2 / 11	10,80	94,4	45	94,4	45	98,2	45	98,2	47,2	98,2	47,2	114,2	47,2	114,2	47,2	260	300	700	3500
XV-2 / 14	14,40	100,4	45	100,4	45	104,2	45	104,2	50,2	104,2	50,2	120,2	50,2	120,2	50,2	250	290	700	3500
XV-2 / 17	16,80	104,4	45	104,4	45	108,2	45	108,2	52,2	108,2	52,2	124,2	52,2	124,2	52,2	230	270	700	3500
XV-2 / 19	19,20	108,4	45	108,4	45	112,2	45	112,2	54,2	112,2	54,2	128,2	54,2	128,2	54,2	210	250	700	3000
XV-2 / 22	22,80	114,4	52,5	114,4	52,5	118,2	52,5	118,2	57,2	118,2	57,2	134,2	57,2	134,2	57,2	200	240	700	3000
XV-2 / 26	26,20	118,4	52,5	118,4	52,5	122,2	52,5	122,2	59,2	122,2	59,2	138,2	59,2	138,2	59,2	170	210	700	3000
XV-2 / 30	30,00	126,4	60,7	126,4	60,7	130,2	60,7	130,2	63,2	130,2	63,2	146,2	63,2	146,2	63,2	160	200	700	2500
XV-2 / 34	34,20	133,4	60,7	133,4	60,7	137,2	60,7	137,2	66,7	137,2	66,7	153,2	66,7	153,2	66,7	150	190	700	2500
XV-2 / 40	39,60	142,4	60,7	142,4	60,7	146,2	60,7	146,2	71,2	146,2	71,2	162,2	71,2	162,2	71,2	140	180	700	2000

MULTIPLE PUMP XV-2

ø 50 "HY" Body-Shaped FLANGE

XV-2

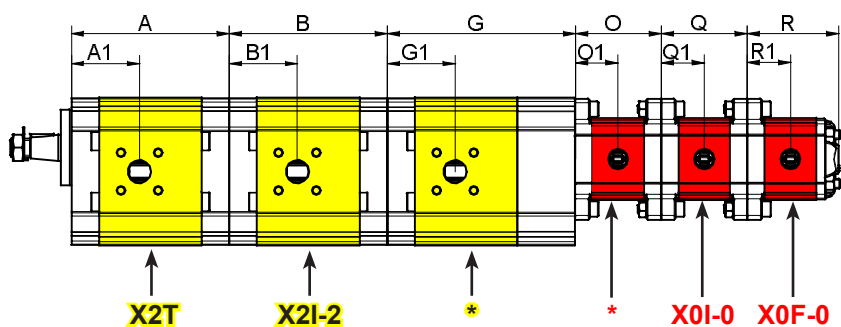
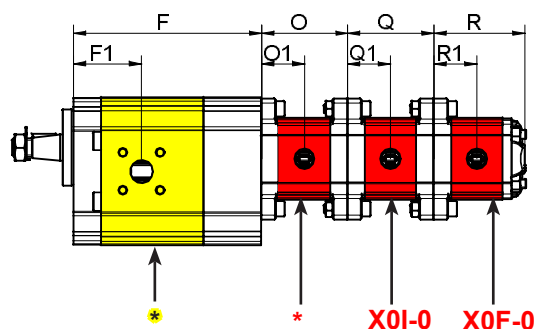
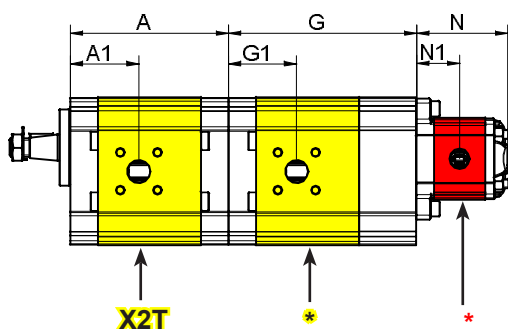
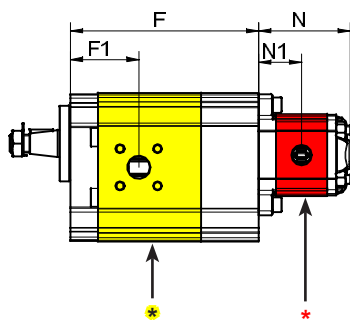

TYPE	Displacement cc/rev	H mm	H1 mm	I mm	I1 mm	L mm	L1 mm	M mm	M1 mm	P1 bar	P3 bar	Min speed rpm	Max speed rpm
XV-1 / 0,9	0,91	77	36,3	73,5	36,3	74,5	37,3	78	37,3	240	280	700	6000
XV-1 / 1,2	1,17	78	36,8	74,5	36,8	75,5	37,8	79	37,8	250	290	700	6000
XV-1 / 1,7	1,56	79,5	37,5	76	37,5	77	38,5	80,5	38,5	250	290	700	6000
XV-1 / 2,2	2,08	81,5	38,5	78	38,5	79	39,5	82,5	39,5	250	290	700	6000
XV-1 / 2,6	2,60	83,5	39,5	80	39,5	81	40,5	84,5	40,5	250	300	700	6000
XV-1 / 3,2	3,12	85,5	40,5	82	40,5	83	41,5	86	41,5	250	300	700	6000
XV-1 / 3,8	3,64	87,5	41,5	84	41,5	85	42,5	88,5	42,5	250	300	700	6000
XV-1 / 4,3	4,26	89,5	42,5	86	42,5	87	43,5	90,5	43,5	250	300	700	6000
XV-1 / 4,9	4,94	92,5	44	89	44	90	45	93,5	45	250	300	700	6000
XV-1 / 5,9	5,85	96	45,8	92,5	45,8	93,5	46,8	97	46,8	250	300	700	5000
XV-1 / 6,5	6,50	98,5	47	95	47	96	48	99,5	48	250	300	700	5000
XV-1 / 7,8	7,54	102,5	49	99	49	100	50	103,5	50	220	260	700	5000
XV-1 / 9,8	9,88	111,5	53,5	108	53,5	109	54,5	112,5	54,5	190	230	700	4000

TYPE	Displacem. cc/rev	N mm	N1 mm	O mm	O1 mm	Q mm	Q1 mm	R mm	R1 mm	P1 bar	P3 bar	Min speed rpm	Max speed rpm
XV-0 / 0,17	0,16	55,8	26,2	52,3	26,2	52,3	26,2	55,8	26,2	220	260	700	9000
XV-0 / 0,25	0,24	56,4	26,5	52,9	26,5	52,9	26,5	56,4	26,5	220	260	700	9000
XV-0 / 0,45	0,45	58	27,3	54,5	27,3	54,5	27,3	58	27,3	220	280	700	9000
XV-0 / 0,57	0,56	59	27,8	55,5	27,8	55,5	27,8	59	27,8	220	280	700	9000
XV-0 / 0,76	0,75	60,5	28,5	57	28,5	57	28,5	60,5	28,5	220	280	700	9000
XV-0 / 0,98	0,92	62	29,3	58,5	29,3	58,5	29,3	62	29,3	220	280	700	6000
XV-0 / 1,27	1,26	64,5	30,5	61	30,5	61	30,5	64,5	30,5	220	280	700	6000
XV-0 / 1,52	1,48	66,5	31,5	63	31,5	63	31,5	66,5	31,5	220	280	700	6000
XV-0 / 2,30	2,28	72,5	34,5	69	34,5	69	34,5	72,5	34,5	220	210	700	5000

MULTIPLE PUMP XV-2

ø 52 - "BH" FLANGE GERMAN STANDARD

XV-2

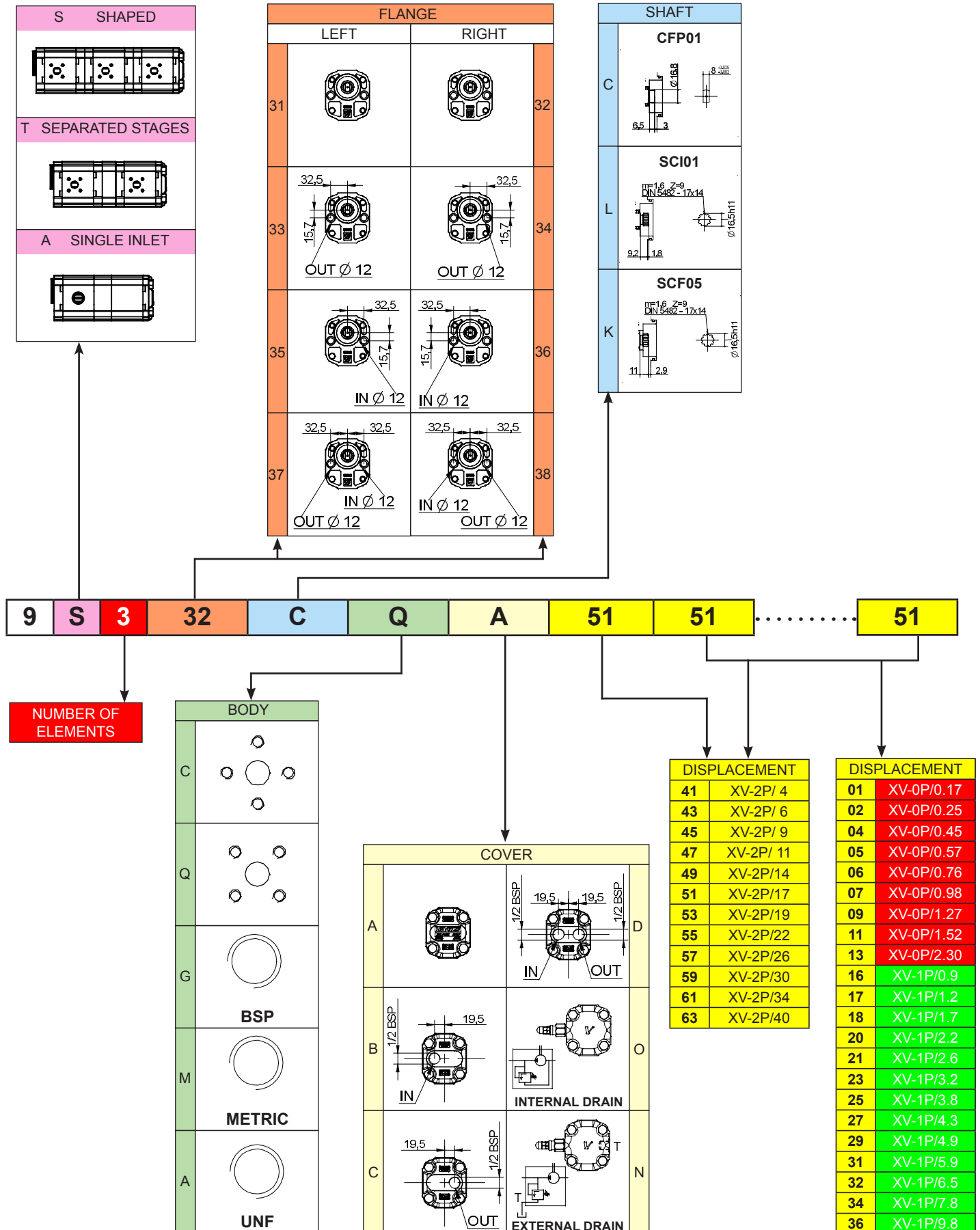

MULTIPLE PUMP XV-2

ø 52 - "BH" FLANGE GERMAN STANDARD

XV-2

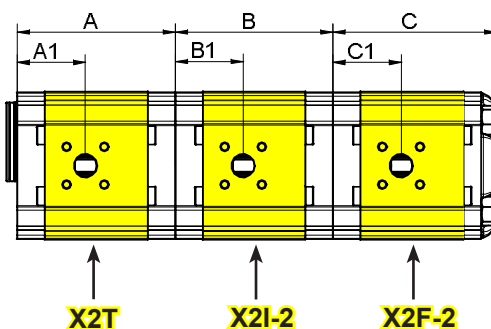
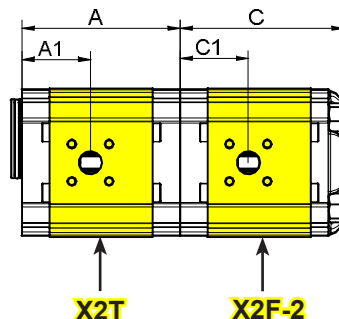
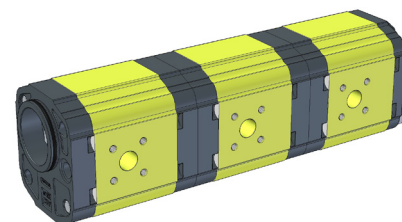
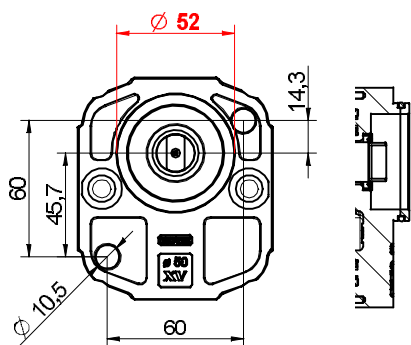

SEPARATED STAGES

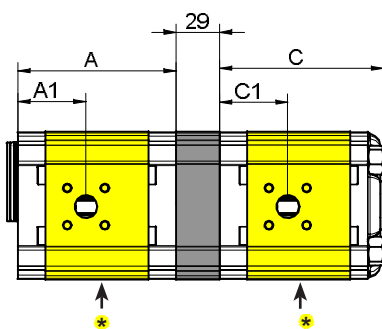

SINGLE INLET

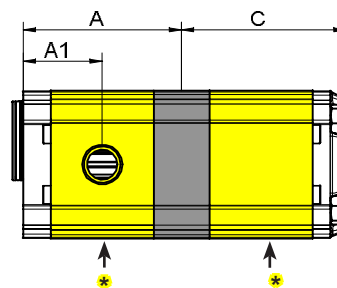

* = SPECIAL ELEMENT, please contact our customer service for details.

TYPE	Displacement cc/rev	A mm	A1 mm	B mm	B1 mm	C mm	C1 mm	P1 bar	P3 bar	Min speed rpm	Max speed rpm
XV-2 / 4	4,20	83,4	38,6	83,4	38,6	87,2	38,6	260	300	700	4000
XV-2 / 6	6,00	86,4	38,6	86,4	38,6	90,2	38,6	260	300	700	3500
XV-2 / 9	8,40	90,4	40,6	90,4	40,6	94,2	40,6	260	300	700	3500
XV-2 / 11	10,80	94,4	45	94,4	45	98,2	45	260	300	700	3500
XV-2 / 14	14,40	100,4	45	100,4	45	104,2	45	250	290	700	3500
XV-2 / 17	16,80	104,4	45	104,4	45	108,2	45	230	270	700	3500
XV-2 / 19	19,20	108,4	45	108,4	45	112,2	45	210	250	700	3000
XV-2 / 22	22,80	114,4	52,5	114,4	52,5	118,2	52,5	200	240	700	3000
XV-2 / 26	26,20	118,4	52,5	118,4	52,5	122,2	52,5	170	210	700	3000
XV-2 / 30	30,00	126,4	60,7	126,4	60,7	130,2	60,7	160	200	700	2500
XV-2 / 34	34,20	133,4	60,7	133,4	60,7	137,2	60,7	150	190	700	2500
XV-2 / 40	39,60	142,4	60,7	142,4	60,7	146,2	60,7	140	180	700	2000

MULTIPLE PUMP XV-2

Ø 52 - "BH" FLANGE GERMAN STANDARD

XV-2

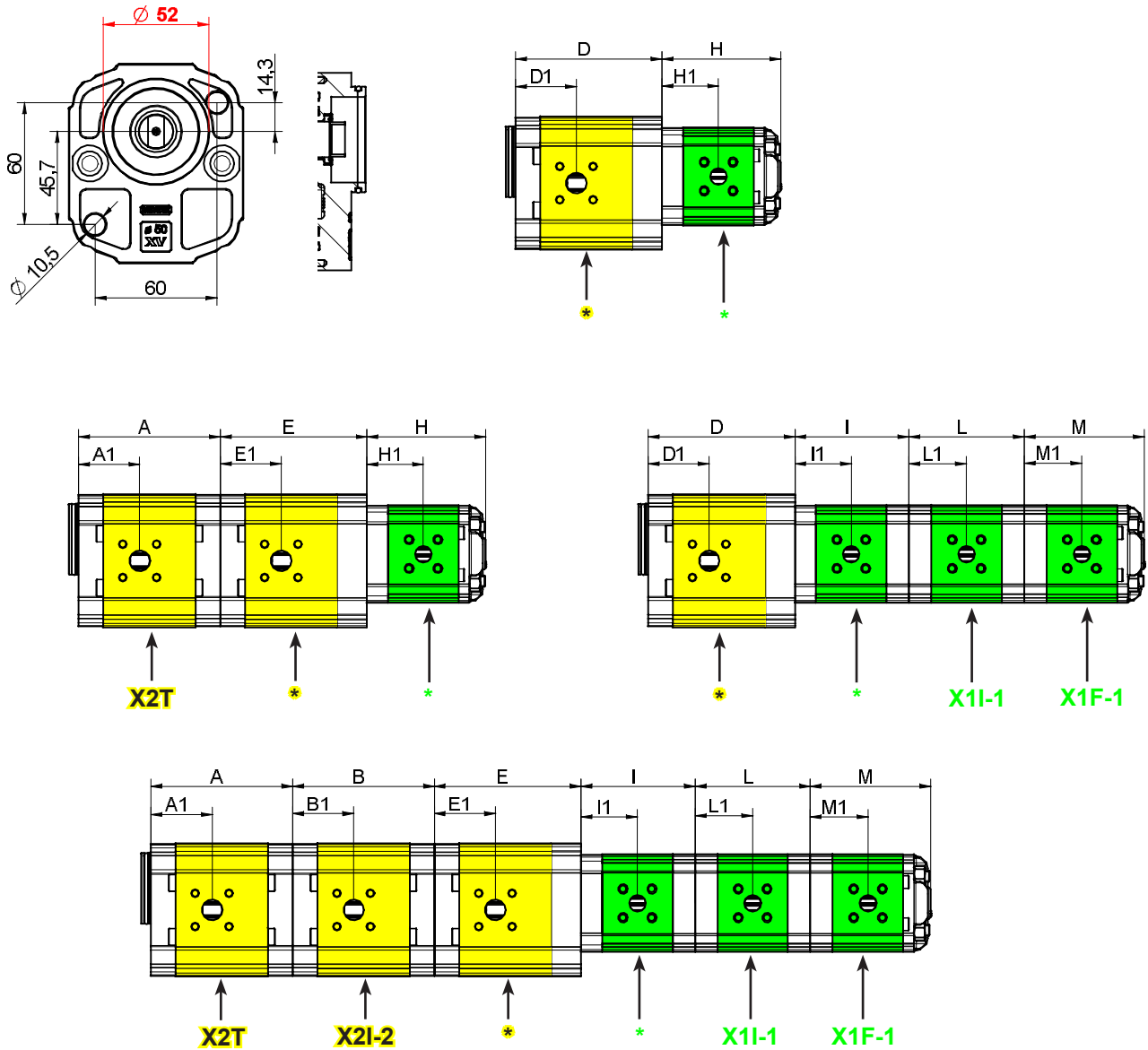

* = SPECIAL ELEMENT, please contact our customer service for details.

TYPE	Displacem. cc/rev	A mm	A1 mm	B mm	B1 mm	C mm	C1 mm	D mm	D1 mm	E mm	E1 mm	F mm	F1 mm	G mm	G1 mm	P1 bar	P3 bar	Min speed rpm	Max speed rpm
XV-2 / 4	4,20	83,4	38,6	83,4	38,6	87,2	38,6	87,2	41,7	87,2	41,7	103,2	41,7	103,2	41,7	260	300	700	4000
XV-2 / 6	6,00	86,4	38,6	86,4	38,6	90,2	38,6	90,2	43,2	90,2	43,2	106,2	43,2	106,2	43,2	260	300	700	3500
XV-2 / 9	8,40	90,4	40,6	90,4	40,6	94,2	40,6	94,2	45,2	94,2	45,2	110,2	45,2	110,2	45,2	260	300	700	3500
XV-2 / 11	10,80	94,4	45	94,4	45	98,2	45	98,2	47,2	98,2	47,2	114,2	47,2	114,2	47,2	260	300	700	3500
XV-2 / 14	14,40	100,4	45	100,4	45	104,2	45	104,2	50,2	104,2	50,2	120,2	50,2	120,2	50,2	250	290	700	3500
XV-2 / 17	16,80	104,4	45	104,4	45	108,2	45	108,2	52,2	108,2	52,2	124,2	52,2	124,2	52,2	230	270	700	3500
XV-2 / 19	19,20	108,4	45	108,4	45	112,2	45	112,2	54,2	112,2	54,2	128,2	54,2	128,2	54,2	210	250	700	3000
XV-2 / 22	22,80	114,4	52,5	114,4	52,5	118,2	52,5	118,2	57,2	118,2	57,2	134,2	57,2	134,2	57,2	200	240	700	3000
XV-2 / 26	26,20	118,4	52,5	118,4	52,5	122,2	52,5	122,2	59,2	122,2	59,2	138,2	59,2	138,2	59,2	170	210	700	3000
XV-2 / 30	30,00	126,4	60,7	126,4	60,7	130,2	60,7	130,2	63,2	130,2	63,2	146,2	63,2	146,2	63,2	160	200	700	2500
XV-2 / 34	34,20	133,4	60,7	133,4	60,7	137,2	60,7	137,2	66,7	137,2	66,7	153,2	66,7	153,2	66,7	150	190	700	2500
XV-2 / 40	39,60	142,4	60,7	142,4	60,7	146,2	60,7	146,2	71,2	146,2	71,2	162,2	71,2	162,2	71,2	140	180	700	2000

MULTIPLE PUMP XV-2

ø 52 - "BH" FLANGE GERMAN STANDARD

XV-2

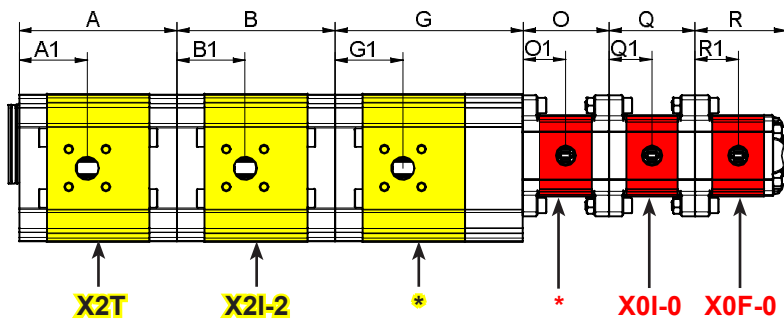
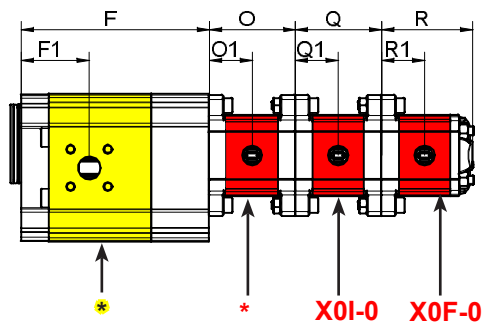
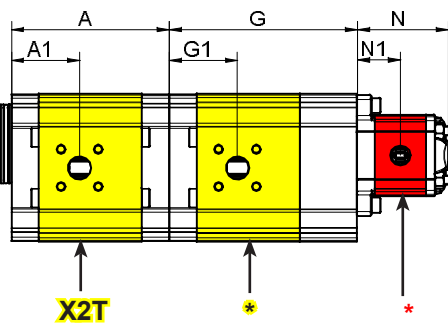
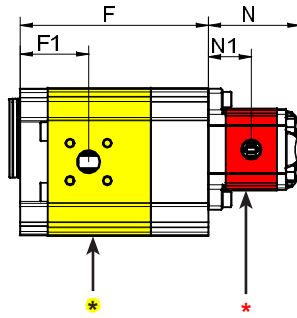

TYPE	Displacement cc/rev	H mm	H1 mm	I mm	I1 mm	L mm	L1 mm	M mm	M1 mm	P1 bar	P3 bar	Min speed rpm	Max speed rpm
XV-1 / 0,9	0,91	77	36,3	73,5	36,3	74,5	37,3	78	37,3	240	280	700	6000
XV-1 / 1,2	1,17	78	36,8	74,5	36,8	75,5	37,8	79	37,8	250	290	700	6000
XV-1 / 1,7	1,56	79,5	37,5	76	37,5	77	38,5	80,5	38,5	250	290	700	6000
XV-1 / 2,2	2,08	81,5	38,5	78	38,5	79	39,5	82,5	39,5	250	290	700	6000
XV-1 / 2,6	2,60	83,5	39,5	80	39,5	81	40,5	84,5	40,5	250	300	700	6000
XV-1 / 3,2	3,12	85,5	40,5	82	40,5	83	41,5	86	41,5	250	300	700	6000
XV-1 / 3,8	3,64	87,5	41,5	84	41,5	85	42,5	88,5	42,5	250	300	700	6000
XV-1 / 4,3	4,26	89,5	42,5	86	42,5	87	43,5	90,5	43,5	250	300	700	6000
XV-1 / 4,9	4,94	92,5	44	89	44	90	45	93,5	45	250	300	700	6000
XV-1 / 5,9	5,85	96	45,8	92,5	45,8	93,5	46,8	97	46,8	250	300	700	5000
XV-1 / 6,5	6,50	98,5	47	95	47	96	48	99,5	48	250	300	700	5000
XV-1 / 7,8	7,54	102,5	49	99	49	100	50	103,5	50	220	260	700	5000
XV-1 / 9,8	9,88	111,5	53,5	108	53,5	109	54,5	112,5	54,5	190	230	700	4000

TYPE	Displacem. cc/rev	N mm	N1 mm	O mm	O1 mm	Q mm	Q1 mm	R mm	R1 mm	P1 bar	P3 bar	Min speed rpm	Max speed rpm
XV-0 / 0,17	0,16	55,8	26,2	52,3	26,2	52,3	26,2	55,8	26,2	220	260	700	9000
XV-0 / 0,25	0,24	56,4	26,5	52,9	26,5	52,9	26,5	56,4	26,5	220	260	700	9000
XV-0 / 0,45	0,45	58	27,3	54,5	27,3	54,5	27,3	58	27,3	220	280	700	9000
XV-0 / 0,57	0,56	59	27,8	55,5	27,8	55,5	27,8	59	27,8	220	280	700	9000
XV-0 / 0,76	0,75	60,5	28,5	57	28,5	57	28,5	60,5	28,5	220	280	700	9000
XV-0 / 0,98	0,92	62	29,3	58,5	29,3	58,5	29,3	62	29,3	220	280	700	6000
XV-0 / 1,27	1,26	64,5	30,5	61	30,5	61	30,5	64,5	30,5	220	280	700	6000
XV-0 / 1,52	1,48	66,5	31,5	63	31,5	63	31,5	66,5	31,5	220	280	700	6000
XV-0 / 2,30	2,28	72,5	34,5	69	34,5	69	34,5	72,5	34,5	220	210	700	5000

MULTIPLE PUMP XV-2

ø 80 German Standard

XV-2

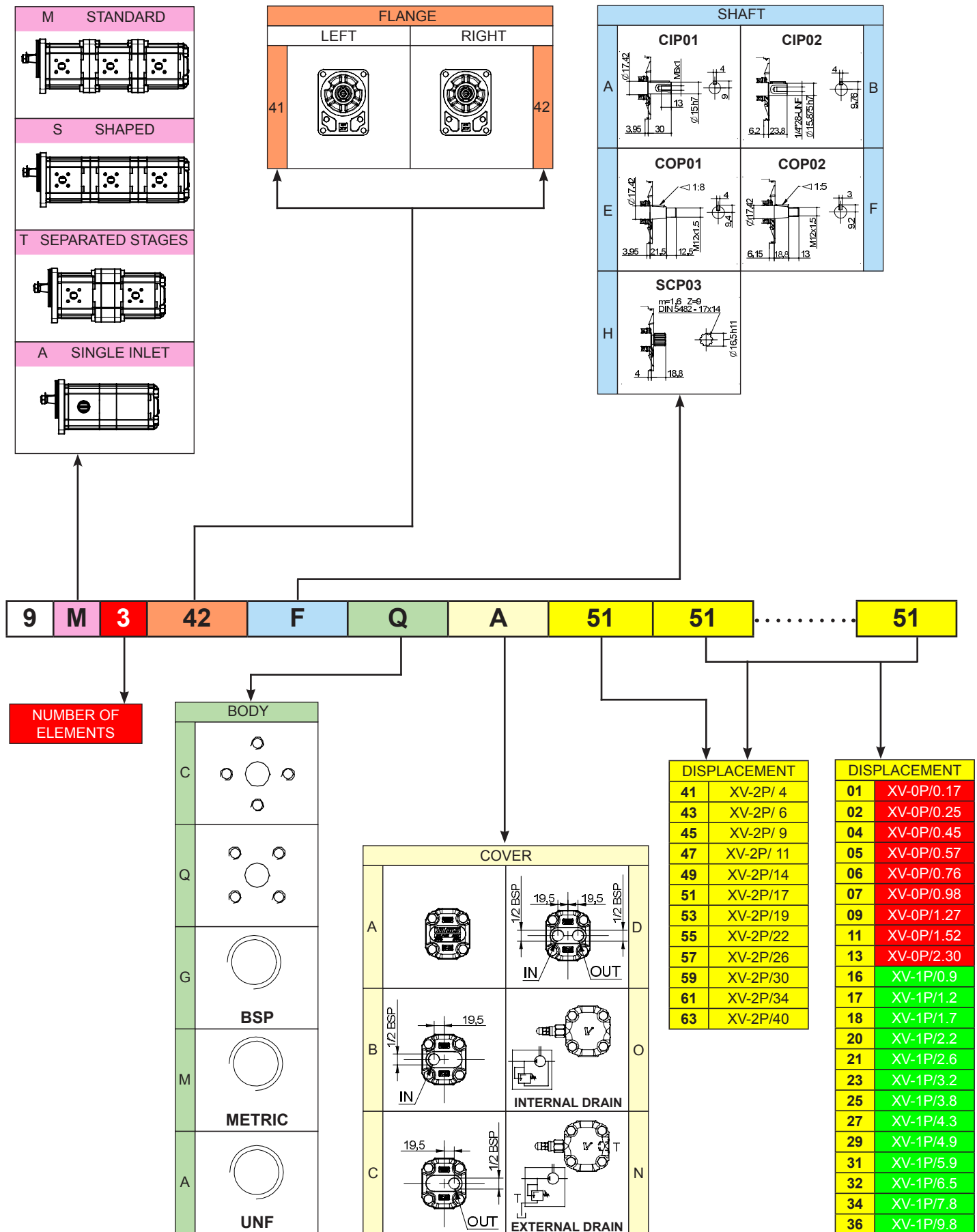

MULTIPLE PUMP XV-2
Ø 80 GERMAN STANDARD

XV-2

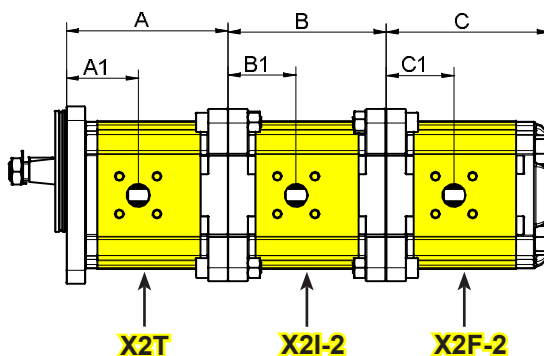
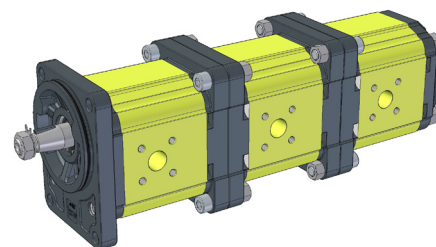
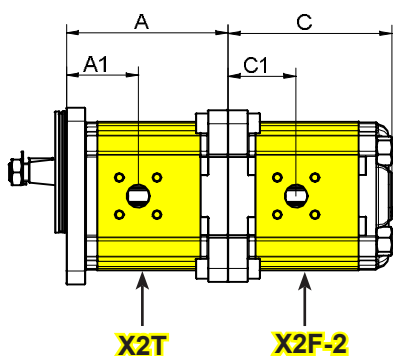
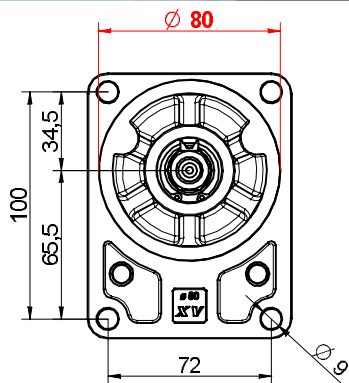

SEPARATED STAGES

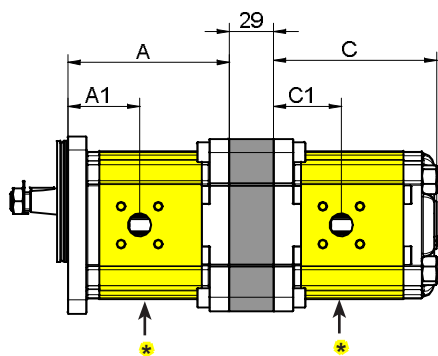

SINGLE INLET

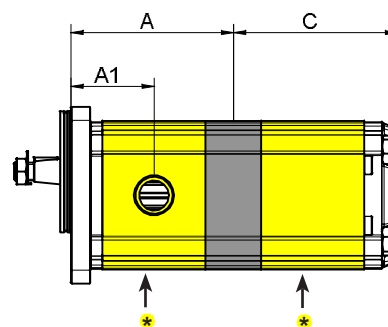

* = SPECIAL ELEMENT, please contact our customer service for details.

TYPE	Displacem. cc/rev	A mm	A1 mm	B mm	B1 mm	C mm	C1 mm	P1 bar	P3 bar	Min speed rpm	Max speed rpm
XV-2 / 4	4,20	85,9	41,1	83,4	41,7	87,2	41,7	260	300	700	4000
XV-2 / 6	6,00	88,9	41,1	86,4	43,2	90,2	43,2	260	300	700	3500
XV-2 / 9	8,40	92,9	43,1	90,4	45,2	94,2	45,2	260	300	700	3500
XV-2 / 11	10,80	96,9	47,5	94,4	47,2	98,2	47,2	260	300	700	3500
XV-2 / 14	14,40	102,9	47,5	100,4	50,2	104,2	50,2	250	290	700	3500
XV-2 / 17	16,80	106,9	47,5	104,4	52,2	108,2	52,2	230	270	700	3500
XV-2 / 19	19,20	110,9	47,5	108,4	54,2	112,2	54,2	210	250	700	3000
XV-2 / 22	22,80	116,9	55	114,4	57,2	118,2	57,2	200	240	700	3000
XV-2 / 26	26,20	120,9	55	118,4	59,2	122,2	59,2	170	210	700	3000
XV-2 / 30	30,00	128,9	63,2	126,4	63,2	130,2	63,2	160	200	700	2500
XV-2 / 34	34,20	135,9	63,2	133,4	66,7	137,2	66,7	150	190	700	2500
XV-2 / 40	39,60	144,9	63,2	142,4	71,2	146,2	71,2	140	180	700	2000

MULTIPLE PUMP XV-2

Ø 80 GERMAN STANDARD

XV-2

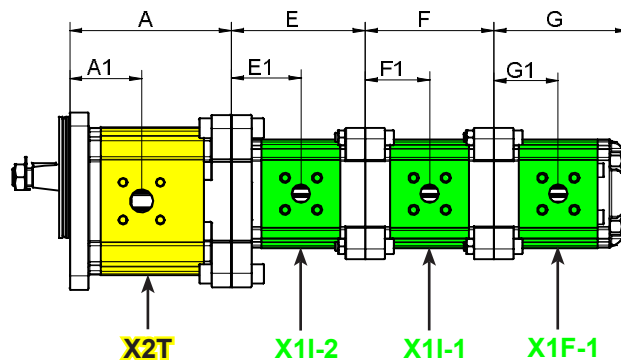
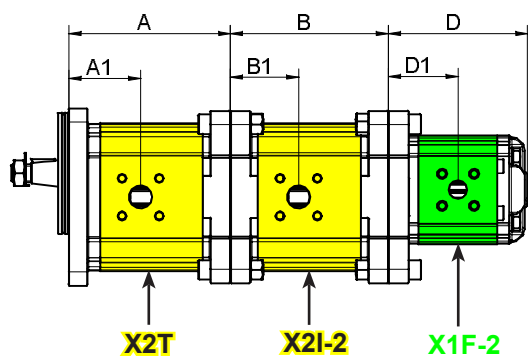
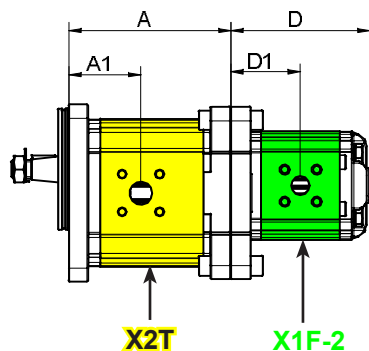
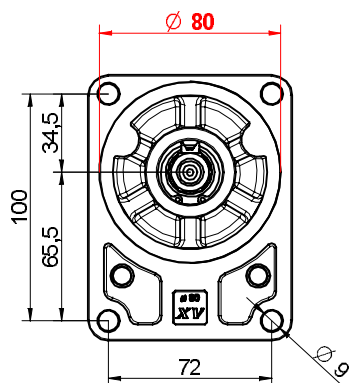

SEPARATED STAGES

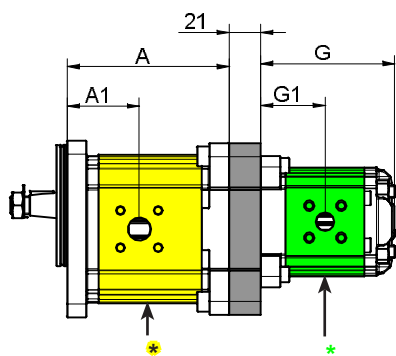

* = SPECIAL ELEMENT, please contact our customer service for details.

TYPE	Displacem. cc/rev	A mm	A1 mm	B mm	B1 mm	C mm	C1 mm	P1 bar	P3 bar	Min speed rpm	Max speed rpm
XV-2 / 4	4,20	85,9	41,1	83,4	41,7	87,2	41,7	260	300	700	4000
XV-2 / 6	6,00	88,9	41,1	86,4	43,2	90,2	43,2	260	300	700	3500
XV-2 / 9	8,40	92,9	43,1	90,4	45,2	94,2	45,2	260	300	700	3500
XV-2 / 11	10,80	96,9	47,5	94,4	47,2	98,2	47,2	260	300	700	3500
XV-2 / 14	14,40	102,9	47,5	100,4	50,2	104,2	50,2	250	290	700	3500
XV-2 / 17	16,80	106,9	47,5	104,4	52,2	108,2	52,2	230	270	700	3500
XV-2 / 19	19,20	110,9	47,5	108,4	54,2	112,2	54,2	210	250	700	3000
XV-2 / 22	22,80	116,9	55	114,4	57,2	118,2	57,2	200	240	700	3000
XV-2 / 26	26,20	120,9	55	118,4	59,2	122,2	59,2	170	210	700	3000
XV-2 / 30	30,00	128,9	63,2	126,4	63,2	130,2	63,2	160	200	700	2500
XV-2 / 34	34,20	135,9	63,2	133,4	66,7	137,2	66,7	150	190	700	2500
XV-2 / 40	39,60	144,9	63,2	142,4	71,2	146,2	71,2	140	180	700	2000

MULTIPLE PUMP XV-2
ø 80 GERMAN STANDARD

XV-2

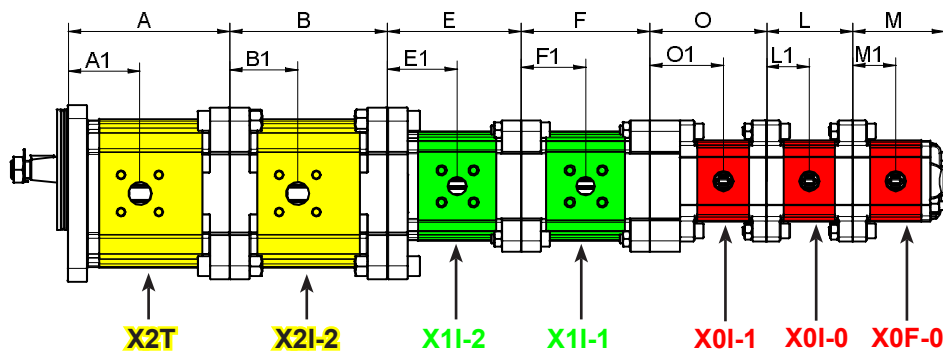
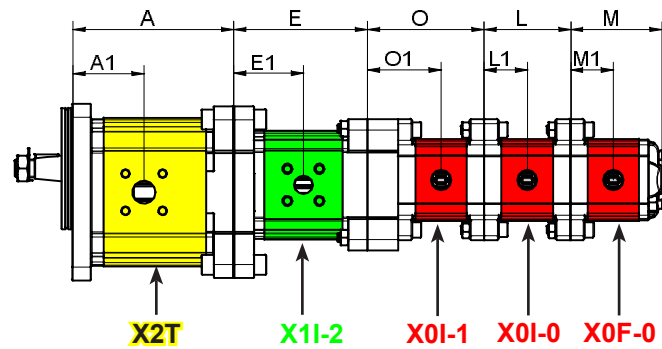
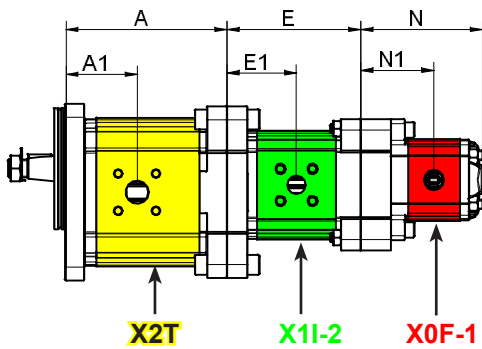
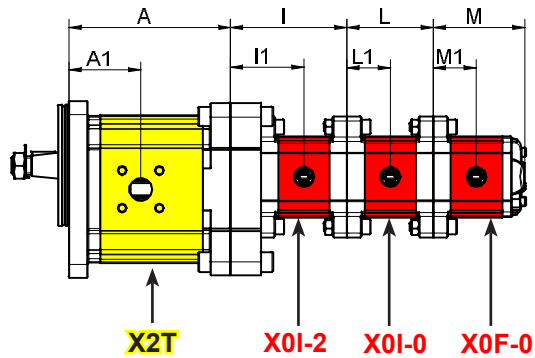
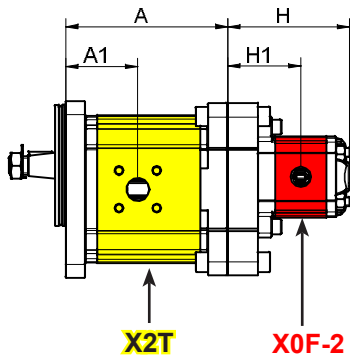

TYPE	Displacem. cc/rev	D mm	D1 mm	E mm	E1 mm	F mm	F1 mm	G mm	G1 mm	P1 bar	P3 bar	Min speed rpm	Max speed rpm
XV-1 / 0,9	0,91	81,5	40,8	78	40,8	74,5	37,3	78	37,3	240	280	700	6000
XV-1 / 1,2	1,17	82,5	41,3	79	41,3	75,5	37,8	79	37,8	250	290	700	6000
XV-1 / 1,7	1,56	84	42	80,5	42	77	38,5	80,5	38,5	250	290	700	6000
XV-1 / 2,2	2,08	86	43	82,5	43	79	39,5	82,5	39,5	250	290	700	6000
XV-1 / 2,6	2,60	88	44	84,5	44	81	40,5	84,5	40,5	250	300	700	6000
XV-1 / 3,2	3,12	90	45	86	45	83	41,5	86	41,5	250	300	700	6000
XV-1 / 3,8	3,64	92	46	88,5	46	85	42,5	88,5	42,5	250	300	700	6000
XV-1 / 4,3	4,26	94	47	90,5	47	87	43,5	90,5	43,5	250	300	700	6000
XV-1 / 4,9	4,94	97	48,5	93,5	48,5	90	45	93,5	45	250	300	700	6000
XV-1 / 5,9	5,85	100,5	50,3	97	50,3	93,5	46,8	97	46,8	250	300	700	5000
XV-1 / 6,5	6,50	103	51,5	99,5	51,5	96	48	99,5	48	250	300	700	5000
XV-1 / 7,8	7,54	107	53,5	103,5	53,5	100	50	103,5	50	220	260	700	5000
XV-1 / 9,8	9,88	116	58	112,5	58	109	54,5	112,5	54,5	190	230	700	4000

TYPE	Displacem. cc/rev	H mm	H1 mm	I mm	I1 mm	L mm	L1 mm	M mm	M1 mm	N mm	N1 mm	O mm	O1 mm	P1 bar	P3 bar	Min speed rpm	Max speed rpm
XV-0 / 0,17	0,16	75,8	46,2	72,3	46,2	52,3	26,2	55,8	26,2	75,8	46,2	72,3	46,2	220	260	700	9000
XV-0 / 0,25	0,24	76,4	46,5	72,9	46,5	52,9	26,5	56,4	26,5	76,4	46,5	72,9	46,5	220	260	700	9000
XV-0 / 0,45	0,45	78	47,3	74,5	47,3	54,5	27,3	58	27,3	78	47,3	74,5	47,3	220	280	700	9000
XV-0 / 0,57	0,56	79	47,8	75,5	47,8	55,5	27,8	59	27,8	79	47,8	75,5	47,8	220	280	700	9000
XV-0 / 0,76	0,75	80,5	48,5	77	48,5	57	28,5	60,5	28,5	80,5	48,5	77	48,5	220	280	700	9000
XV-0 / 0,98	0,92	82	49,3	78,5	49,3	58,5	29,3	62	29,3	82	49,3	78,5	49,3	220	280	700	6000
XV-0 / 1,27	1,26	84,5	50,5	81	50,5	61	30,5	64,5	30,5	84,5	50,5	81	50,5	220	280	700	6000
XV-0 / 1,52	1,48	86,5	51,5	83	51,5	63	31,5	66,5	31,5	86,5	51,5	83	51,5	220	280	700	6000
XV-0 / 2,30	2,28	92,5	54,5	89	54,5	69	34,5	72,5	34,5	92,5	54,5	89	54,5	220	210	700	5000

MULTIPLE PUMP XV-2
ø 82,5 - FLANGE "SAE A"

XV-2

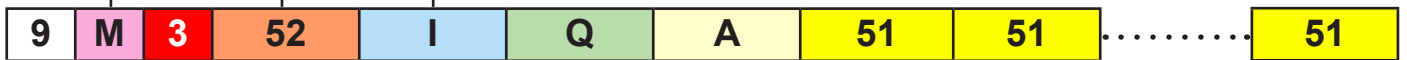
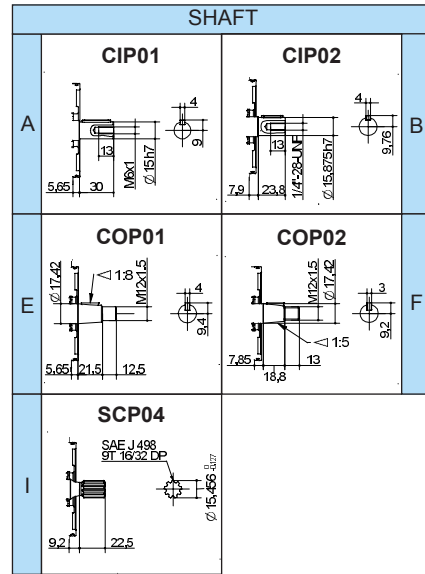
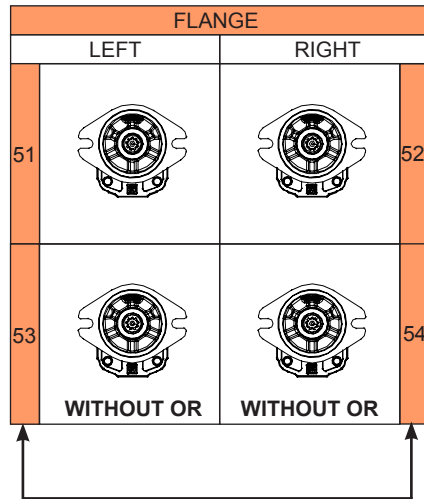
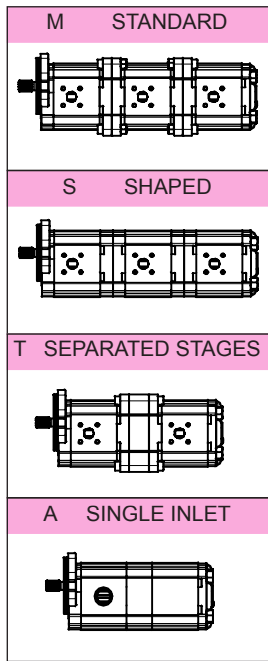

NUMBER OF ELEMENTS

BODY	
C	
Q	
G	
BSP	
M	
METRIC	
A	
UNF	

COVER	
A	
B	
C	
D	
O	
N	

DISPLACEMENT	
41	XV-2P/ 4
43	XV-2P/ 6
45	XV-2P/ 9
47	XV-2P/ 11
49	XV-2P/14
51	XV-2P/17
53	XV-2P/19
55	XV-2P/22
57	XV-2P/26
59	XV-2P/30
61	XV-2P/34
63	XV-2P/40

DISPLACEMENT	
01	XV-0P/0.17
02	XV-0P/0.25
04	XV-0P/0.45
05	XV-0P/0.57
06	XV-0P/0.76
07	XV-0P/0.98
09	XV-0P/1.27
11	XV-0P/1.52
13	XV-0P/2.30
16	XV-1P/0.9
17	XV-1P/1.2
18	XV-1P/1.7
20	XV-1P/2.2
21	XV-1P/2.6
23	XV-1P/3.2
25	XV-1P/3.8
27	XV-1P/4.3
29	XV-1P/4.9
31	XV-1P/5.9
32	XV-1P/6.5
34	XV-1P/7.8
36	XV-1P/9.8

MULTIPLE PUMP XV-2
ø 82,5 - FLANGE "SAE A"

XV-2

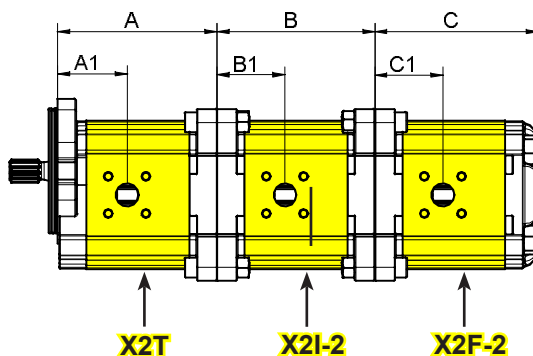
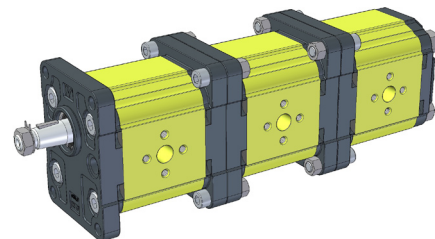
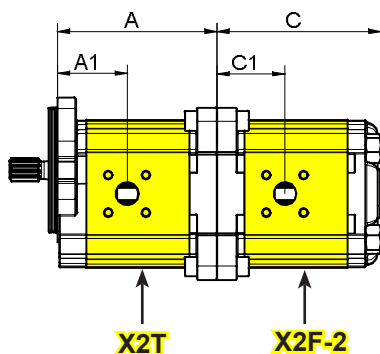
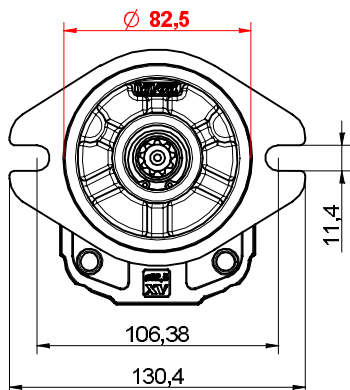

SEPARATED STAGES

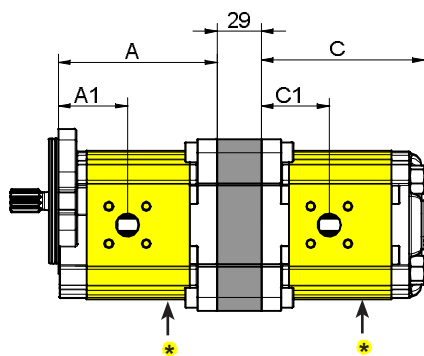

SINGLE INLET

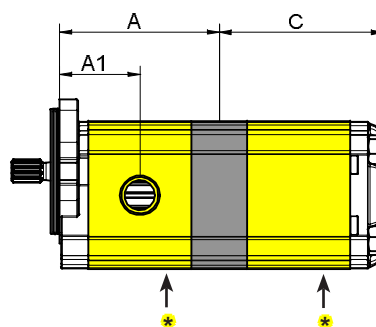

* = SPECIAL ELEMENT, please contact our customer service for details.

TYPE	Displacem. cc/rev	A mm	A1 mm	B mm	B1 mm	C mm	C1 mm	P1 bar	P3 bar	Min speed rpm	Max speed rpm
XV-2 / 4	4,20	84,2	39,4	83,4	41,7	87,2	41,7	260	300	700	4000
XV-2 / 6	6,00	87,2	39,4	86,4	43,2	90,2	43,2	260	300	700	3500
XV-2 / 9	8,40	91,2	41,4	90,4	45,2	94,2	45,2	260	300	700	3500
XV-2 / 11	10,80	95,2	45,8	94,4	47,2	98,2	47,2	260	300	700	3500
XV-2 / 14	14,40	101,2	45,8	100,4	50,2	104,2	50,2	250	290	700	3500
XV-2 / 17	16,80	105,2	45,8	104,4	52,2	108,2	52,2	230	270	700	3500
XV-2 / 19	19,20	109,2	45,8	108,4	54,2	112,2	54,2	210	250	700	3000
XV-2 / 22	22,80	115,2	53,3	114,4	57,2	118,2	57,2	200	240	700	3000
XV-2 / 26	26,20	119,2	53,3	118,4	59,2	122,2	59,2	170	210	700	3000
XV-2 / 30	30,00	127,2	61,5	126,4	63,2	130,2	63,2	160	200	700	2500
XV-2 / 34	34,20	134,2	61,5	133,4	66,7	137,2	66,7	150	190	700	2500
XV-2 / 40	39,60	143,2	61,5	142,4	71,2	146,2	71,2	140	180	700	2000

MULTIPLE PUMP XV-2

Ø 82,5 - FLANGE "SAE A"

XV-2

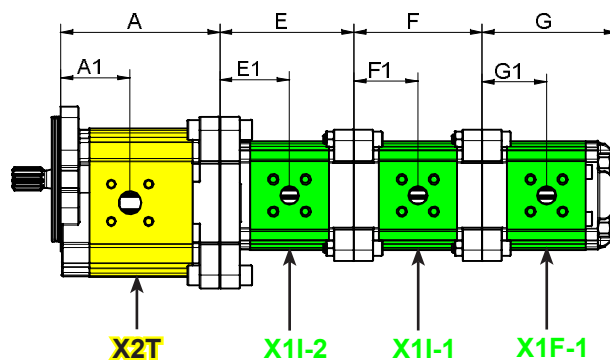
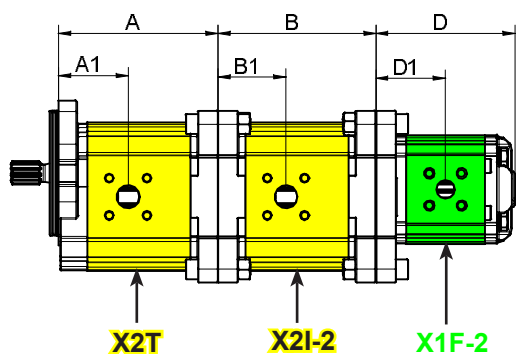
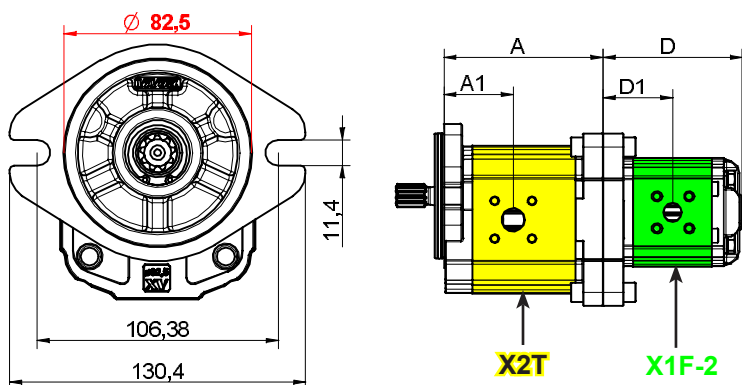

SEPARATED STAGES

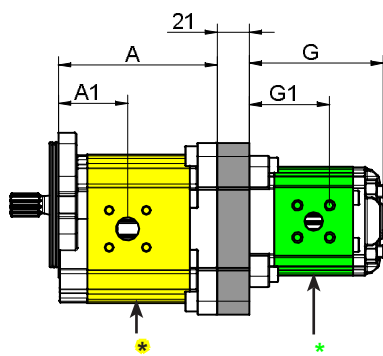

* = SPECIAL ELEMENT, please contact our customer service for details.

TYPE	Displacem. cc/rev	A mm	A1 mm	B mm	B1 mm	C mm	C1 mm	P1 bar	P3 bar	Min speed rpm	Max speed rpm
XV-2 / 4	4,20	84,2	39,4	83,4	41,7	87,2	41,7	260	300	700	4000
XV-2 / 6	6,00	87,2	39,4	86,4	43,2	90,2	43,2	260	300	700	3500
XV-2 / 9	8,40	91,2	41,4	90,4	45,2	94,2	45,2	260	300	700	3500
XV-2 / 11	10,80	95,2	45,8	94,4	47,2	98,2	47,2	260	300	700	3500
XV-2 / 14	14,40	101,2	45,8	100,4	50,2	104,2	50,2	250	290	700	3500
XV-2 / 17	16,80	105,2	45,8	104,4	52,2	108,2	52,2	230	270	700	3500
XV-2 / 19	19,20	109,2	45,8	108,4	54,2	112,2	54,2	210	250	700	3000
XV-2 / 22	22,80	115,2	53,3	114,4	57,2	118,2	57,2	200	240	700	3000
XV-2 / 26	26,20	119,2	53,3	118,4	59,2	122,2	59,2	170	210	700	3000
XV-2 / 30	30,00	127,2	61,5	126,4	63,2	130,2	63,2	160	200	700	2500
XV-2 / 34	34,20	134,2	61,5	133,4	66,7	137,2	66,7	150	190	700	2500
XV-2 / 40	39,60	143,2	61,5	142,4	71,2	146,2	71,2	140	180	700	2000

MULTIPLE PUMP XV-2

ø 82,5 - FLANGE "SAE A"

XV-2

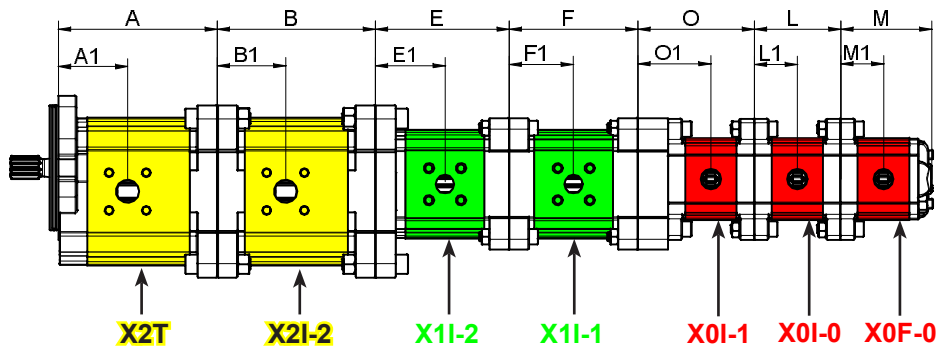
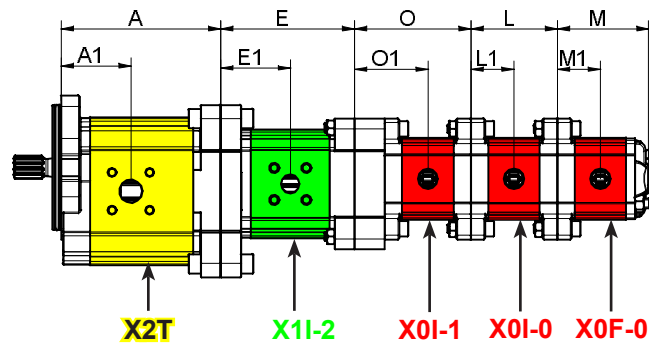
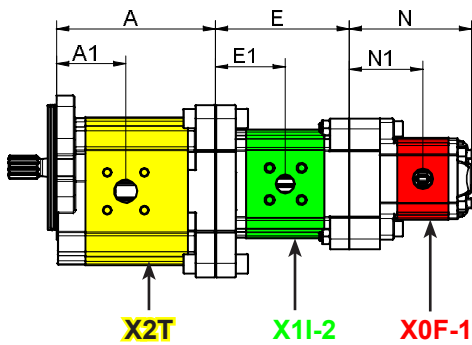
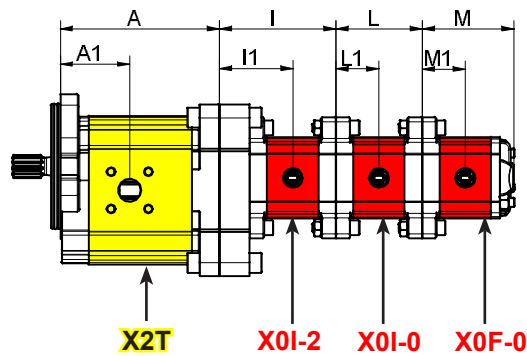
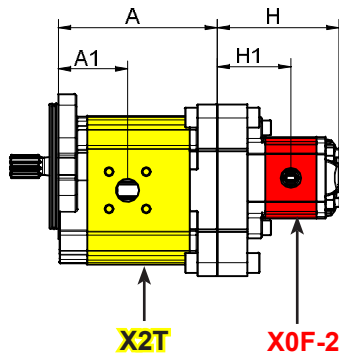

TYPE	Displacem. cc/rev	D mm	D1 mm	E mm	E1 mm	F mm	F1 mm	G mm	G1 mm	P1 bar	P3 bar	Min speed rpm	Max speed rpm
XV-1 / 0,9	0,91	81,5	40,8	78	40,8	74,5	37,3	78	37,3	240	280	700	6000
XV-1 / 1,2	1,17	82,5	41,3	79	41,3	75,5	37,8	79	37,8	250	290	700	6000
XV-1 / 1,7	1,56	84	42	80,5	42	77	38,5	80,5	38,5	250	290	700	6000
XV-1 / 2,2	2,08	86	43	82,5	43	79	39,5	82,5	39,5	250	290	700	6000
XV-1 / 2,6	2,60	88	44	84,5	44	81	40,5	84,5	40,5	250	300	700	6000
XV-1 / 3,2	3,12	90	45	86	45	83	41,5	86	41,5	250	300	700	6000
XV-1 / 3,8	3,64	92	46	88,5	46	85	42,5	88,5	42,5	250	300	700	6000
XV-1 / 4,3	4,26	94	47	90,5	47	87	43,5	90,5	43,5	250	300	700	6000
XV-1 / 4,9	4,94	97	48,5	93,5	48,5	90	45	93,5	45	250	300	700	6000
XV-1 / 5,9	5,85	100,5	50,3	97	50,3	93,5	46,8	97	46,8	250	300	700	5000
XV-1 / 6,5	6,50	103	51,5	99,5	51,5	96	48	99,5	48	250	300	700	5000
XV-1 / 7,8	7,54	107	53,5	103,5	53,5	100	50	103,5	50	220	260	700	5000
XV-1 / 9,8	9,88	116	58	112,5	58	109	54,5	112,5	54,5	190	230	700	4000

TYPE	Displacem. cc/rev	H mm	H1 mm	I mm	I1 mm	L mm	L1 mm	M mm	M1 mm	N mm	N1 mm	O mm	O1 mm	P1 bar	P3 bar	Min speed rpm	Max speed rpm
XV-0 / 0,17	0,16	75,8	46,2	72,3	46,2	52,3	26,2	55,8	26,2	75,8	46,2	72,3	46,2	220	260	700	9000
XV-0 / 0,25	0,24	76,4	46,5	72,9	46,5	52,9	26,5	56,4	26,5	76,4	46,5	72,9	46,5	220	260	700	9000
XV-0 / 0,45	0,45	78	47,3	74,5	47,3	54,5	27,3	58	27,3	78	47,3	74,5	47,3	220	280	700	9000
XV-0 / 0,57	0,56	79	47,8	75,5	47,8	55,5	27,8	59	27,8	79	47,8	75,5	47,8	220	280	700	9000
XV-0 / 0,76	0,75	80,5	48,5	77	48,5	57	28,5	60,5	28,5	80,5	48,5	77	48,5	220	280	700	9000
XV-0 / 0,98	0,92	82	49,3	78,5	49,3	58,5	29,3	62	29,3	82	49,3	78,5	49,3	220	280	700	6000
XV-0 / 1,27	1,26	84,5	50,5	81	50,5	61	30,5	64,5	30,5	84,5	50,5	81	50,5	220	280	700	6000
XV-0 / 1,52	1,48	86,5	51,5	83	51,5	63	31,5	66,5	31,5	86,5	51,5	83	51,5	220	280	700	6000
XV-0 / 2,30	2,28	92,5	54,5	89	54,5	69	34,5	72,5	34,5	92,5	54,5	89	54,5	220	210	700	5000

MULTIPLE PUMP XV-3

ø 50,8 FLANGE

XV-3

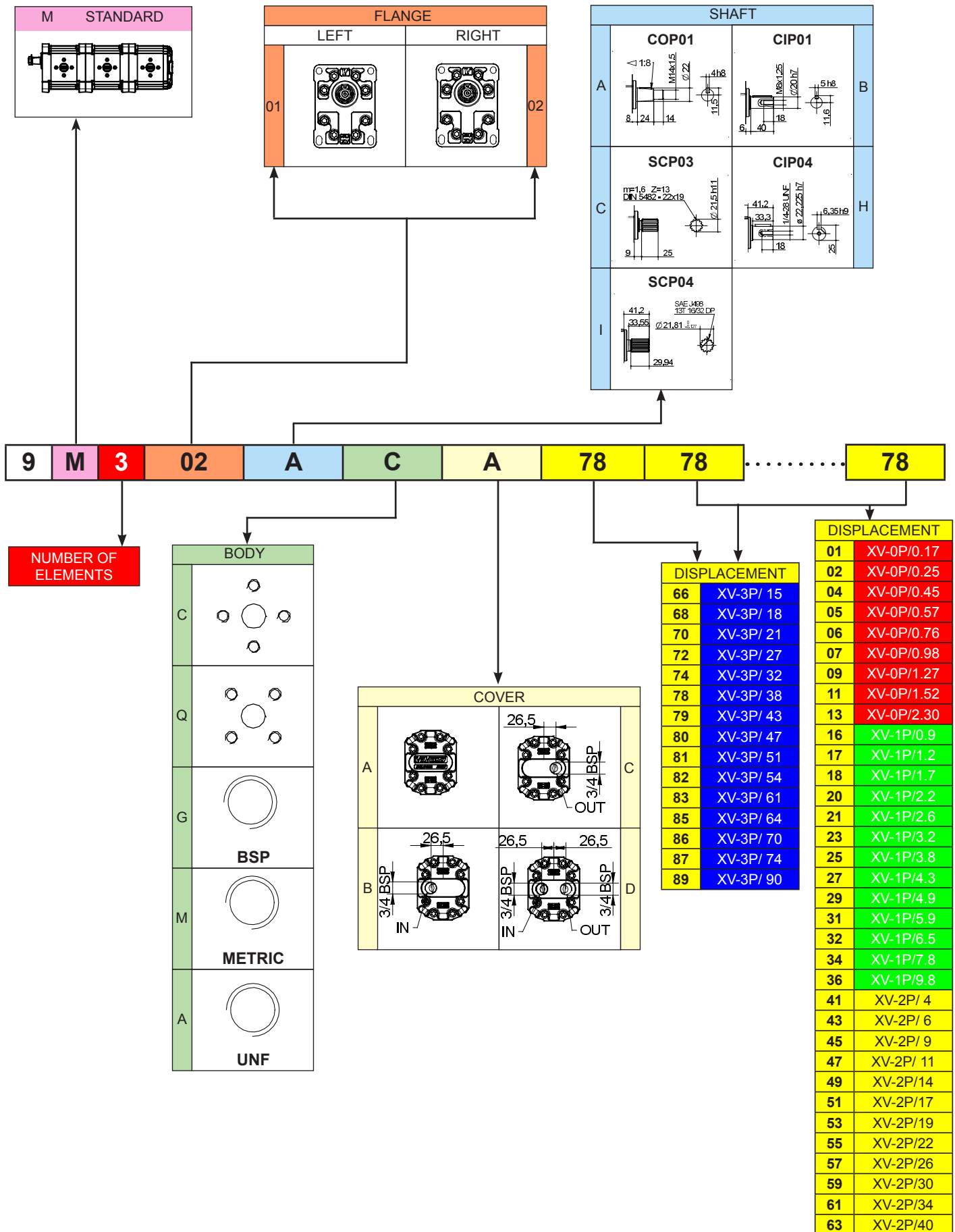

MULTIPLE PUMP XV-3

ø 50,8 FLANGE

XV-3

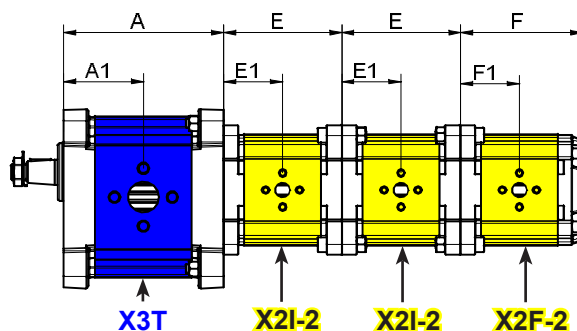
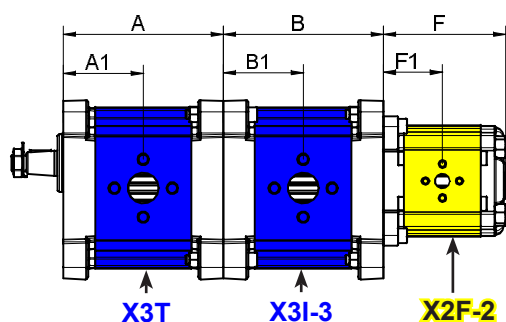
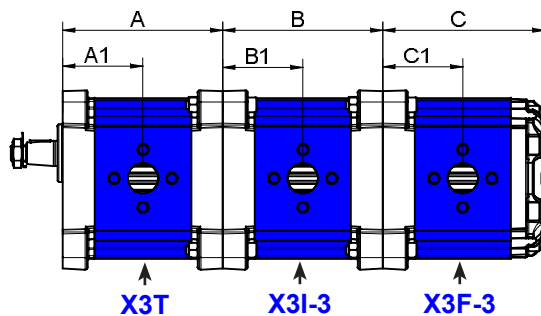
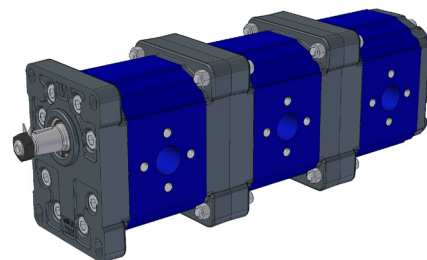
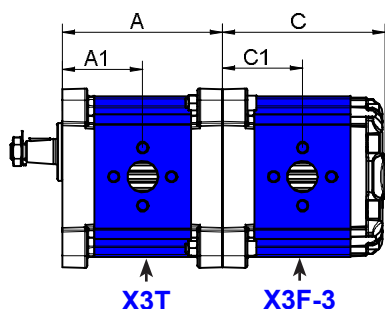
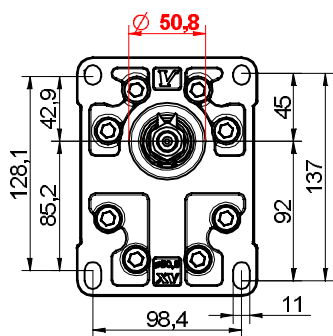

TYPE	Displacem. cc/rev	A mm	A1 mm	B mm	B1 mm	C mm	C1 mm	P1 bar	P3 bar	Min speed rpm	Max speed rpm
XV-3 / 15	14,89	122	61	122	61	124	61	300	320	700	3000
XV-3 / 18	17,37	124	62	124	62	126	62	300	320	700	3000
XV-3 / 21	21,10	127	63,5	127	63,5	129	63,5	280	300	700	3000
XV-3 / 27	26,97	131	65,5	131	65,5	133	65,5	250	270	700	3000
XV-3 / 32	32,27	136	68	136	68	138	68	250	270	700	3000
XV-3 / 38	38,47	141	70,5	141	70,5	143	70,5	250	270	700	2800
XV-3 / 43	43,44	145	72,5	145	72,5	147	72,5	250	270	700	2800
XV-3 / 47	47,16	148	74	148	74	150	74	230	250	700	2800
XV-3 / 51	50,88	151	75,5	151	75,5	153	75,5	230	250	700	2800
XV-3 / 54	54,60	154	77	154	77	156	77	230	250	700	2300
XV-3 / 61	60,81	159	79,5	159	79,5	161	79,5	230	250	700	2300
XV-3 / 64	64,53	162	81	162	81	164	81	210	230	700	2300
XV-3 / 70	70,74	167	83,5	167	83,5	169	83,5	200	220	700	2300
XV-3 / 74	74,46	170	85	170	85	172	85	180	200	700	2300
XV-3 / 90	86,87	180	90	180	90	182	90	150	170	700	2300

TYPE	Displacem. cc/rev	E mm	E1 mm	F mm	F1 mm	P1 bar	P3 bar	Min speed rpm	Max speed rpm
XV-2 / 4	4,20	83,4	41,7	87,2	41,7	260	300	700	4000
XV-2 / 6	6,00	86,4	43,2	90,2	43,2	260	300	700	3500
XV-2 / 9	8,40	90,4	45,2	94,2	45,2	260	300	700	3500
XV-2 / 11	10,80	94,4	47,2	98,2	47,2	260	300	700	3500
XV-2 / 14	14,40	100,4	50,2	104,2	50,2	250	290	700	3500
XV-2 / 17	16,80	104,4	52,2	108,2	52,2	230	270	700	3500
XV-2 / 19	19,20	108,4	54,2	112,2	54,2	210	250	700	3000
XV-2 / 22	22,80	114,4	57,2	118,2	57,2	200	240	700	3000
XV-2 / 26	26,20	118,4	59,2	122,2	59,2	170	210	700	3000
XV-2 / 30	30,00	126,4	63,2	130,2	63,2	160	200	700	2500
XV-2 / 34	34,20	133,4	66,7	137,2	66,7	150	190	700	2500
XV-2 / 40	39,60	142,4	71,2	146,2	71,2	140	180	700	2000

MULTIPLE PUMP XV-3
BASE \varnothing 50,8 - STANDARD

XV-3

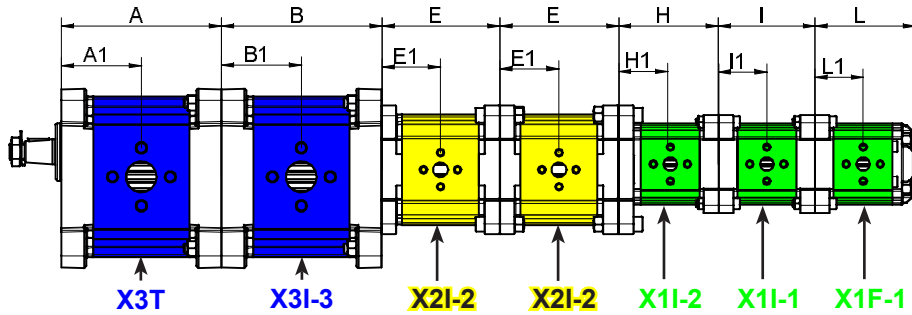
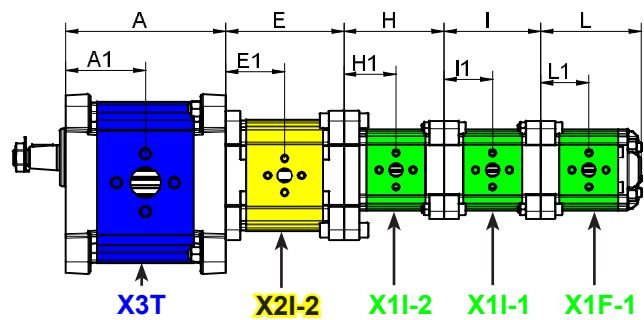
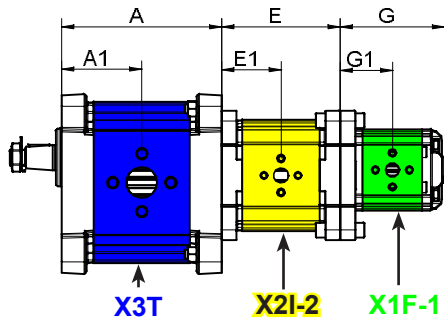
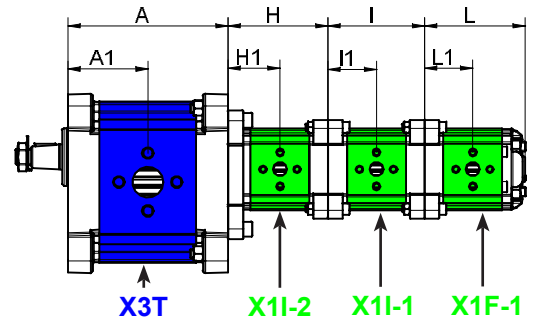
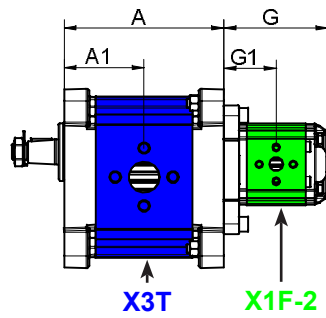
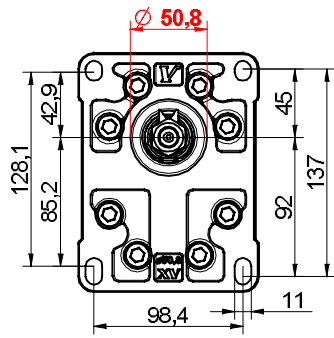

TYPE	Displacem. cc/rev	A mm	A1 mm	B mm	B1 mm	C mm	C1 mm	P1 bar	P3 bar	Min speed rpm	Max speed rpm
XV-3 / 15	14,89	122	61	122	61	124	61	300	320	700	3000
XV-3 / 18	17,37	124	62	124	62	126	62	300	320	700	3000
XV-3 / 21	21,10	127	63,5	127	63,5	129	63,5	280	300	700	3000
XV-3 / 27	26,97	131	65,5	131	65,5	133	65,5	250	270	700	3000
XV-3 / 32	32,27	136	68	136	68	138	68	250	270	700	3000
XV-3 / 38	38,47	141	70,5	141	70,5	143	70,5	250	270	700	2800
XV-3 / 43	43,44	145	72,5	145	72,5	147	72,5	250	270	700	2800
XV-3 / 47	47,16	148	74	148	74	150	74	230	250	700	2800
XV-3 / 51	50,88	151	75,5	151	75,5	153	75,5	230	250	700	2800
XV-3 / 54	54,60	154	77	154	77	156	77	230	250	700	2300
XV-3 / 61	60,81	159	79,5	159	79,5	161	79,5	230	250	700	2300
XV-3 / 64	64,53	162	81	162	81	164	81	210	230	700	2300
XV-3 / 70	70,74	167	83,5	167	83,5	169	83,5	200	220	700	2300
XV-3 / 74	74,46	170	85	170	85	172	85	180	200	700	2300
XV-3 / 90	86,87	180	90	180	90	182	90	150	170	700	2300

TYPE	Displacem. cc/rev	E mm	E1 mm	F mm	F1 mm	P1 bar	P3 bar	Min speed rpm	Max speed rpm
XV-2 / 4	4,20	83,4	41,7	87,2	41,7	260	300	700	4000
XV-2 / 6	6,00	86,4	43,2	90,2	43,2	260	300	700	3500
XV-2 / 9	8,40	90,4	45,2	94,2	45,2	260	300	700	3500
XV-2 / 11	10,80	94,4	47,2	98,2	47,2	260	300	700	3500
XV-2 / 14	14,40	100,4	50,2	104,2	50,2	250	290	700	3500
XV-2 / 17	16,80	104,4	52,2	108,2	52,2	230	270	700	3500
XV-2 / 19	19,20	108,4	54,2	112,2	54,2	210	250	700	3000
XV-2 / 22	22,80	114,4	57,2	118,2	57,2	200	240	700	3000
XV-2 / 26	26,20	118,4	59,2	122,2	59,2	170	210	700	3000
XV-2 / 30	30,00	126,4	63,2	130,2	63,2	160	200	700	2500
XV-2 / 34	34,20	133,4	66,7	137,2	66,7	150	190	700	2500
XV-2 / 40	39,60	142,4	71,2	146,2	71,2	140	180	700	2000

MULTIPLE PUMP XV-3

ø 50,8 FLANGE

XV-3

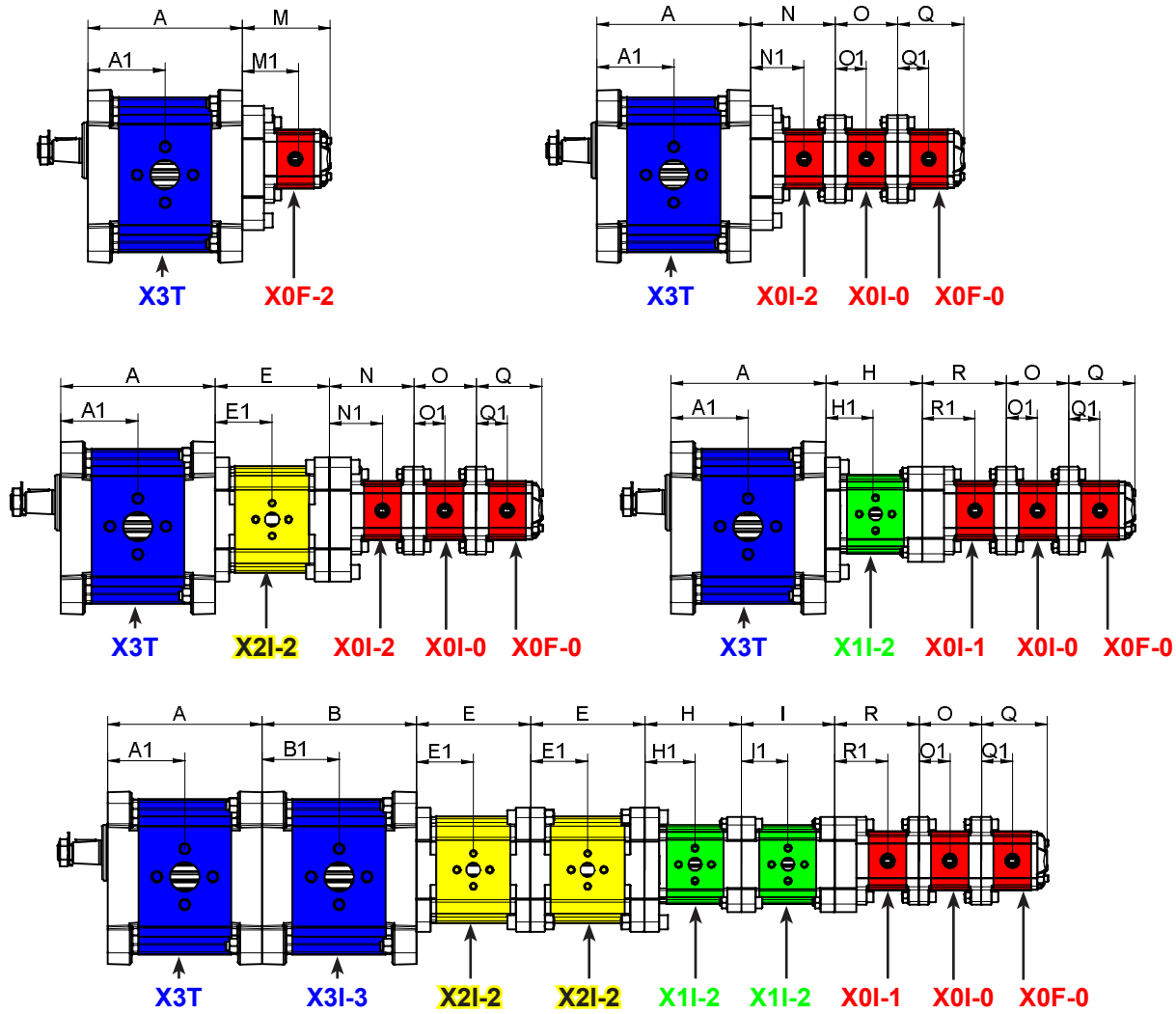

TYPE	Displacem. cc/rev	G mm	G1 mm	H mm	H1 mm	I mm	I1 mm	L mm	L1 mm	P1 bar	P3 bar	Min speed rpm	Max speed rpm
XV-1 / 0,9	0,91	81,5	40,8	78	40,8	74,5	37,3	78	37,3	240	280	700	6000
XV-1 / 1,2	1,17	82,5	41,3	79	41,3	75,5	37,8	79	37,8	250	290	700	6000
XV-1 / 1,7	1,56	84	42	80,5	42	77	38,5	80,5	38,5	250	290	700	6000
XV-1 / 2,2	2,08	86	43	82,5	43	79	39,5	82,5	39,5	250	290	700	6000
XV-1 / 2,6	2,60	88	44	84,5	44	81	40,5	84,5	40,5	250	300	700	6000
XV-1 / 3,2	3,12	90	45	86	45	83	41,5	86	41,5	250	300	700	6000
XV-1 / 3,8	3,64	92	46	88,5	46	85	42,5	88,5	42,5	250	300	700	6000
XV-1 / 4,3	4,26	94	47	90,5	47	87	43,5	90,5	43,5	250	300	700	6000
XV-1 / 4,9	4,94	97	48,5	93,5	48,5	90	45	93,5	45	250	300	700	6000
XV-1 / 5,9	5,85	100,5	50,3	97	50,3	93,5	46,8	97	46,8	250	300	700	5000
XV-1 / 6,5	6,50	103	51,5	99,5	51,5	96	48	99,5	48	250	300	700	5000
XV-1 / 7,8	7,54	107	53,5	103,5	53,5	100	50	103,5	50	220	260	700	5000
XV-1 / 9,8	9,88	116	58	112,5	58	109	54,5	112,5	54,5	190	230	700	4000

TYPE	Displacem. cc/rev	M mm	M1 mm	N mm	N1 mm	O mm	O1 mm	Q mm	Q1 mm	R mm	R1 mm	P1 bar	P3 bar	Min speed rpm	Max speed rpm
XV-0 / 0,17	0,16	75,8	46,2	72,3	46,2	52,3	26,2	55,8	26,2	72,3	46,2	220	260	700	9000
XV-0 / 0,25	0,24	76,4	46,5	72,9	46,5	52,9	26,5	56,4	26,5	72,9	46,5	220	260	700	9000
XV-0 / 0,45	0,45	78	47,3	74,5	47,3	54,5	27,3	58	27,3	74,5	47,3	220	280	700	9000
XV-0 / 0,57	0,56	79	47,8	75,5	47,8	55,5	27,8	59	27,8	75,5	47,8	220	280	700	9000
XV-0 / 0,76	0,75	80,5	48,5	77	48,5	57	28,5	60,5	28,5	77	48,5	220	280	700	9000
XV-0 / 0,98	0,92	82	49,3	78,5	49,3	58,5	29,3	62	29,3	78,5	49,3	220	280	700	6000
XV-0 / 1,27	1,26	84,5	50,5	81	50,5	61	30,5	64,5	30,5	81	50,5	220	280	700	6000
XV-0 / 1,52	1,48	86,5	51,5	83	51,5	63	31,5	66,5	31,5	83	51,5	220	280	700	6000
XV-0 / 2,30	2,28	92,5	54,5	89	54,5	69	34,5	72,5	34,5	89	54,5	220	210	700	5000

MULTIPLE PUMP XV-3

Ø 101,6 FLANGE "SAE B"

XV-3

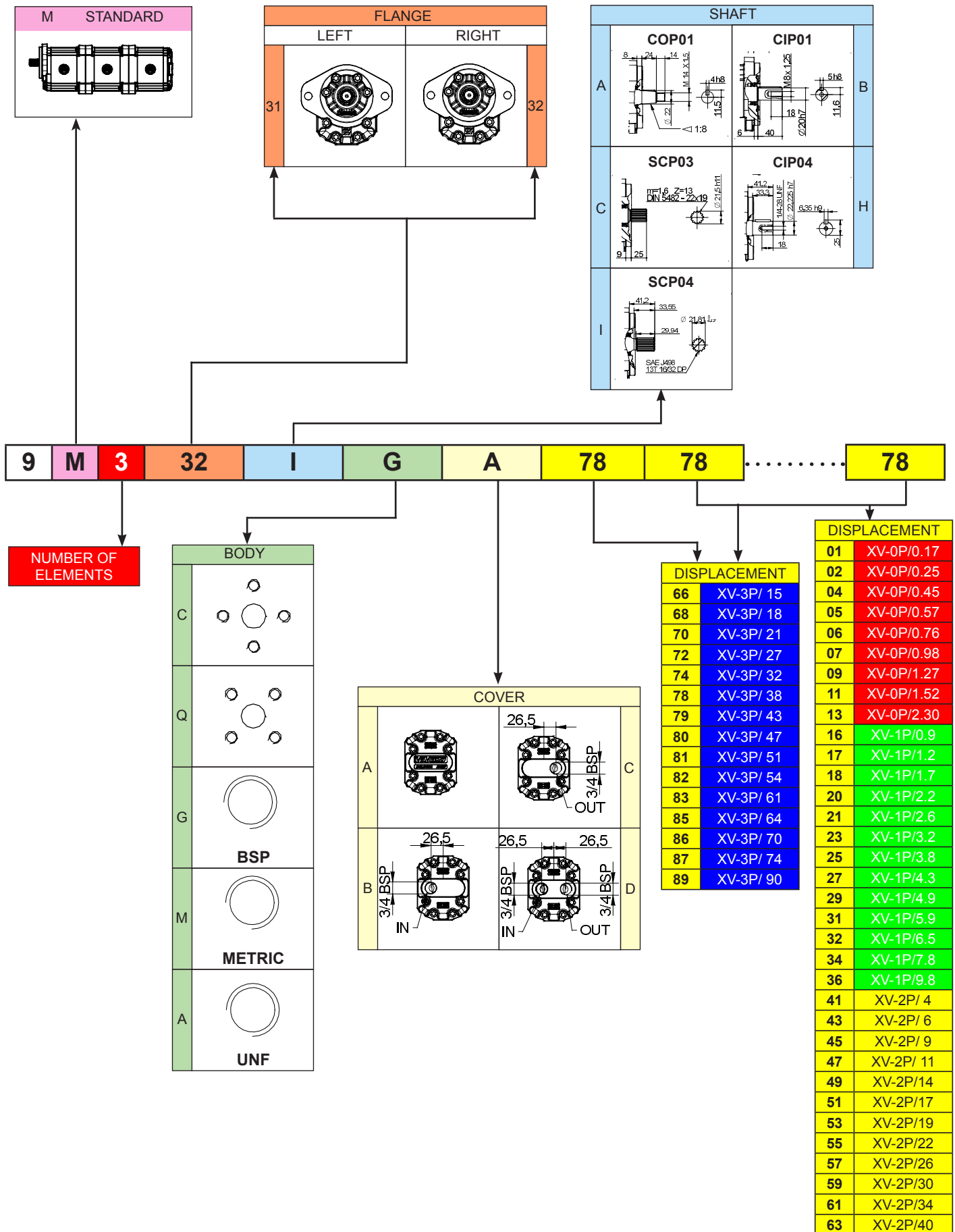

MULTIPLE PUMP XV-3

Ø 101,6 FLANGE "SAE B"

XV-3

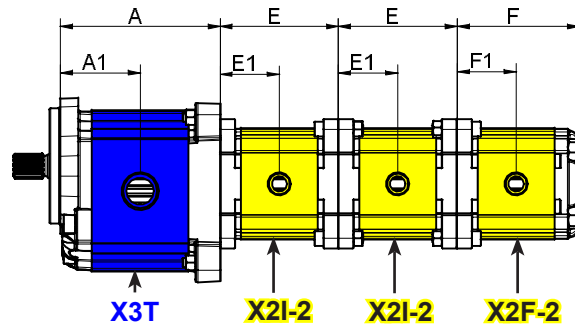
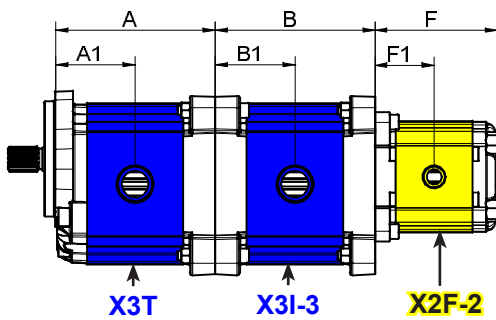
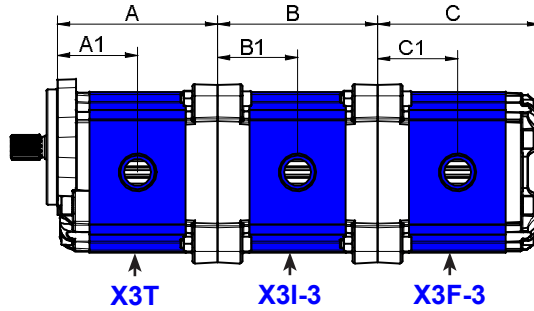
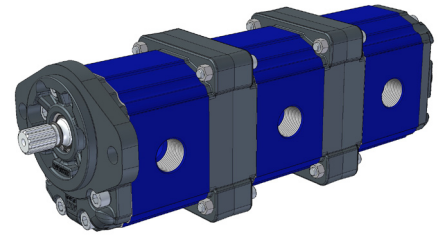
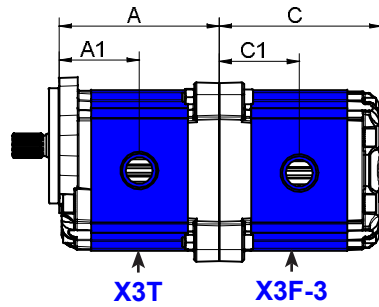
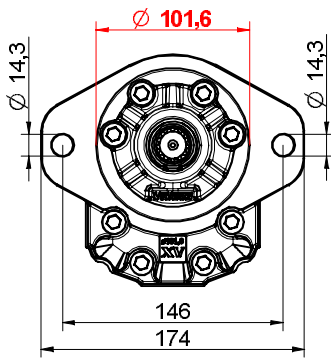

TYPE	Displacem. cc/rev	A mm	A1 mm	B mm	B1 mm	C mm	C1 mm	P1 bar	P3 bar	Min speed rpm	Max speed rpm
XV-3 / 15	14,89	122	61	122	61	124	61	300	320	700	3000
XV-3 / 18	17,37	124	62	124	62	126	62	300	320	700	3000
XV-3 / 21	21,10	127	63,5	127	63,5	129	63,5	280	300	700	3000
XV-3 / 27	26,97	131	65,5	131	65,5	133	65,5	250	270	700	3000
XV-3 / 32	32,27	136	68	136	68	138	68	250	270	700	3000
XV-3 / 38	38,47	141	70,5	141	70,5	143	70,5	250	270	700	2800
XV-3 / 43	43,44	145	72,5	145	72,5	147	72,5	250	270	700	2800
XV-3 / 47	47,16	148	74	148	74	150	74	230	250	700	2800
XV-3 / 51	50,88	151	75,5	151	75,5	153	75,5	230	250	700	2800
XV-3 / 54	54,60	154	77	154	77	156	77	230	250	700	2300
XV-3 / 61	60,81	159	79,5	159	79,5	161	79,5	230	250	700	2300
XV-3 / 64	64,53	162	81	162	81	164	81	210	230	700	2300
XV-3 / 70	70,74	167	83,5	167	83,5	169	83,5	200	220	700	2300
XV-3 / 74	74,46	170	85	170	85	172	85	180	200	700	2300
XV-3 / 90	86,87	180	90	180	90	182	90	150	170	700	2300

TYPE	Displacem. cc/rev	E mm	E1 mm	F mm	F1 mm	P1 bar	P3 bar	Min speed rpm	Max speed rpm
XV-2 / 4	4,20	83,4	41,7	87,2	41,7	260	300	700	4000
XV-2 / 6	6,00	86,4	43,2	90,2	43,2	260	300	700	3500
XV-2 / 9	8,40	90,4	45,2	94,2	45,2	260	300	700	3500
XV-2 / 11	10,80	94,4	47,2	98,2	47,2	260	300	700	3500
XV-2 / 14	14,40	100,4	50,2	104,2	50,2	250	290	700	3500
XV-2 / 17	16,80	104,4	52,2	108,2	52,2	230	270	700	3500
XV-2 / 19	19,20	108,4	54,2	112,2	54,2	210	250	700	3000
XV-2 / 22	22,80	114,4	57,2	118,2	57,2	200	240	700	3000
XV-2 / 26	26,20	118,4	59,2	122,2	59,2	170	210	700	3000
XV-2 / 30	30,00	126,4	63,2	130,2	63,2	160	200	700	2500
XV-2 / 34	34,20	133,4	66,7	137,2	66,7	150	190	700	2500
XV-2 / 40	39,60	142,4	71,2	146,2	71,2	140	180	700	2000

MULTIPLE PUMP XV-3

Ø 101,6 FLANGE "SAE B"

XV-3

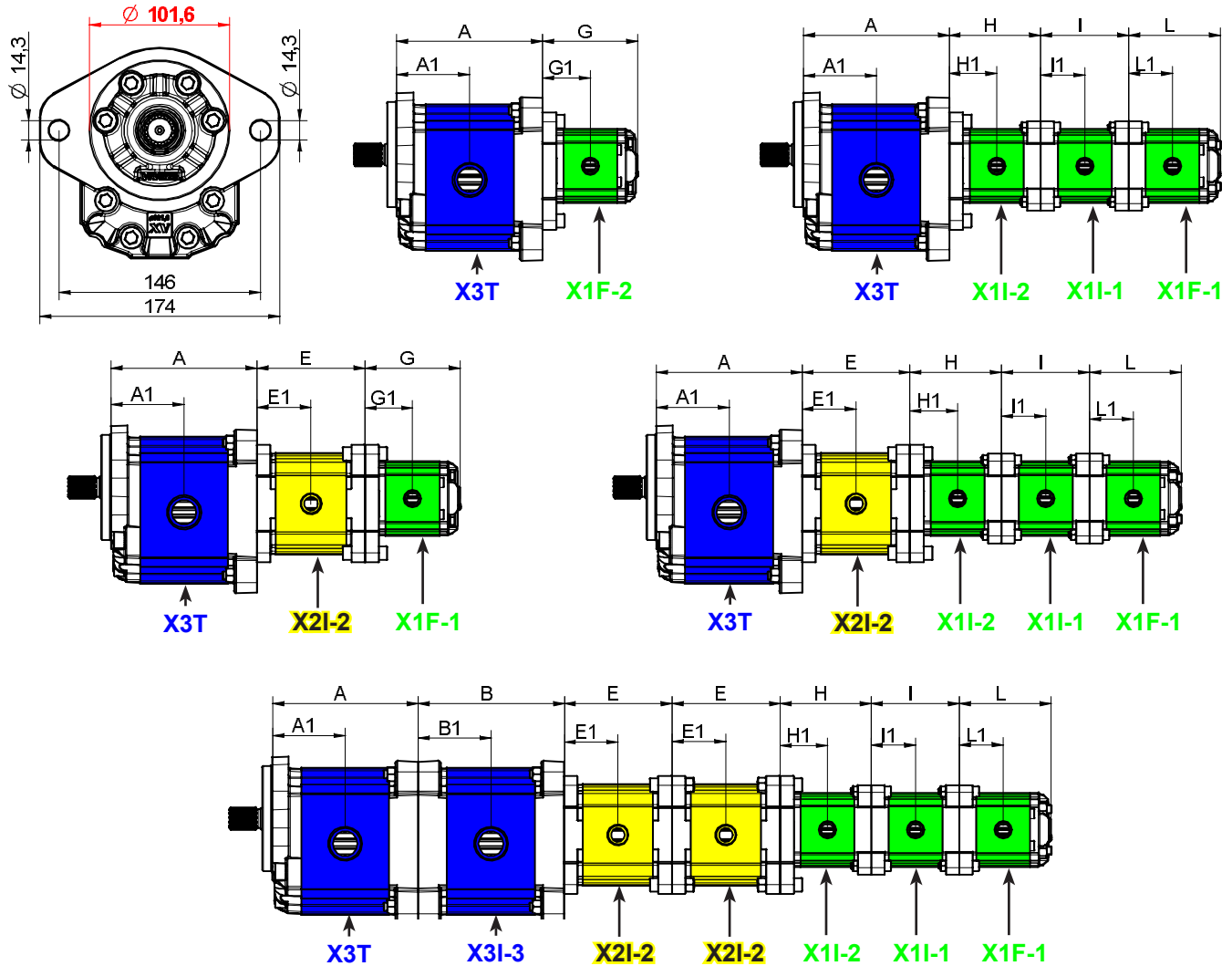

TYPE	Displacem. cc/rev	A mm	A1 mm	B mm	B1 mm	C mm	C1 mm	P1 bar	P3 bar	Min speed rpm	Max speed rpm
XV-3 / 15	14,89	122	61	122	61	124	61	300	320	700	3000
XV-3 / 18	17,37	124	62	124	62	126	62	300	320	700	3000
XV-3 / 21	21,10	127	63,5	127	63,5	129	63,5	280	300	700	3000
XV-3 / 27	26,97	131	65,5	131	65,5	133	65,5	250	270	700	3000
XV-3 / 32	32,27	136	68	136	68	138	68	250	270	700	3000
XV-3 / 38	38,47	141	70,5	141	70,5	143	70,5	250	270	700	2800
XV-3 / 43	43,44	145	72,5	145	72,5	147	72,5	250	270	700	2800
XV-3 / 47	47,16	148	74	148	74	150	74	230	250	700	2800
XV-3 / 51	50,88	151	75,5	151	75,5	153	75,5	230	250	700	2800
XV-3 / 54	54,60	154	77	154	77	156	77	230	250	700	2300
XV-3 / 61	60,81	159	79,5	159	79,5	161	79,5	230	250	700	2300
XV-3 / 64	64,53	162	81	162	81	164	81	210	230	700	2300
XV-3 / 70	70,74	167	83,5	167	83,5	169	83,5	200	220	700	2300
XV-3 / 74	74,46	170	85	170	85	172	85	180	200	700	2300
XV-3 / 90	86,87	180	90	180	90	182	90	150	170	700	2300

TYPE	Displacem. cc/rev	E mm	E1 mm	F mm	F1 mm	P1 bar	P3 bar	Min speed rpm	Max speed rpm
XV-2 / 4	4,20	83,4	41,7	87,2	41,7	260	300	700	4000
XV-2 / 6	6,00	86,4	43,2	90,2	43,2	260	300	700	3500
XV-2 / 9	8,40	90,4	45,2	94,2	45,2	260	300	700	3500
XV-2 / 11	10,80	94,4	47,2	98,2	47,2	260	300	700	3500
XV-2 / 14	14,40	100,4	50,2	104,2	50,2	250	290	700	3500
XV-2 / 17	16,80	104,4	52,2	108,2	52,2	230	270	700	3500
XV-2 / 19	19,20	108,4	54,2	112,2	54,2	210	250	700	3000
XV-2 / 22	22,80	114,4	57,2	118,2	57,2	200	240	700	3000
XV-2 / 26	26,20	118,4	59,2	122,2	59,2	170	210	700	3000
XV-2 / 30	30,00	126,4	63,2	130,2	63,2	160	200	700	2500
XV-2 / 34	34,20	133,4	66,7	137,2	66,7	150	190	700	2500
XV-2 / 40	39,60	142,4	71,2	146,2	71,2	140	180	700	2000

MULTIPLE PUMP XV-3

ø 101,6 FLANGE "SAE B"

XV-3

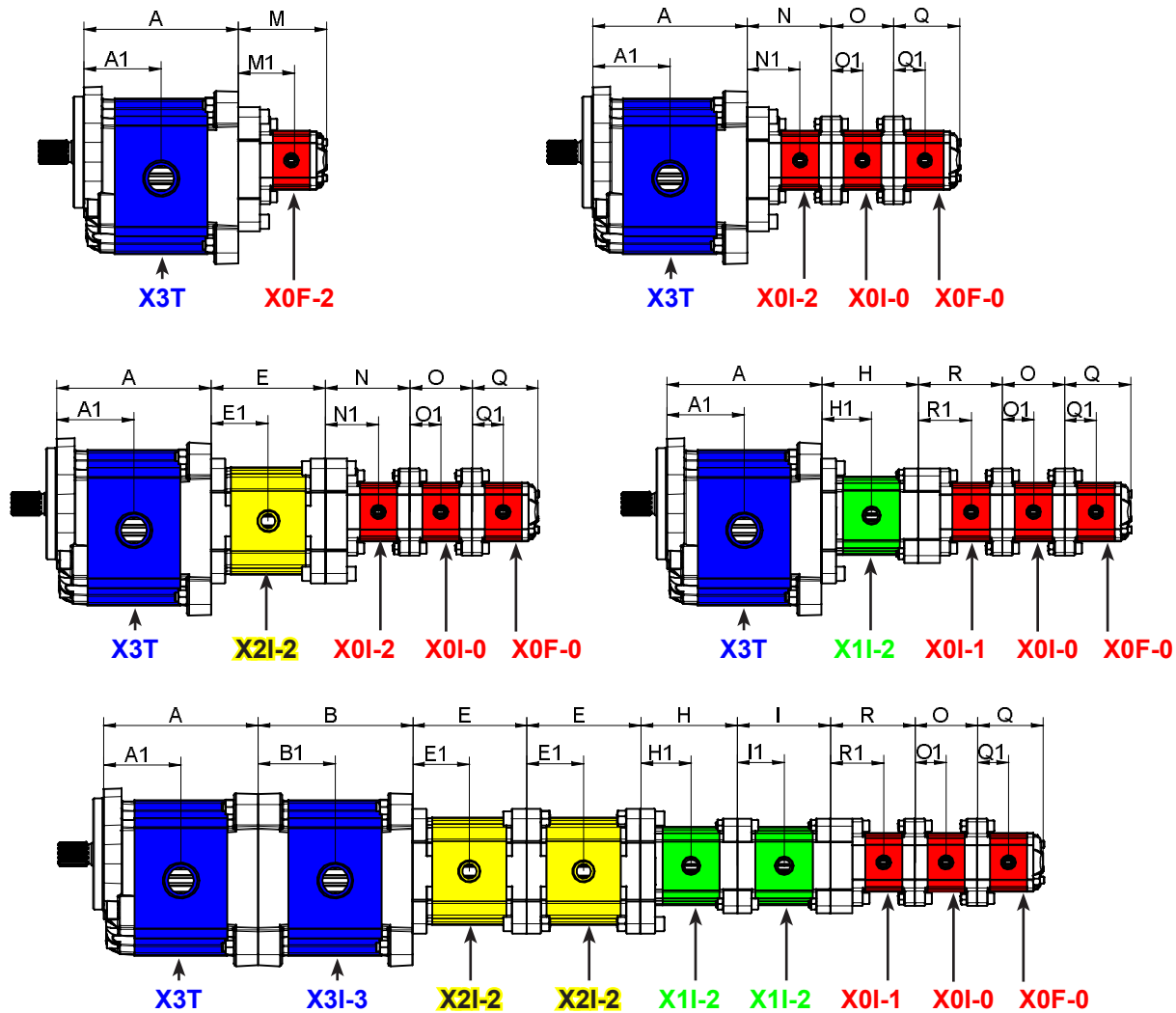

TYPE	Displacem. cc/rev	G mm	G1 mm	H mm	H1 mm	I mm	I1 mm	L mm	L1 mm	P1 bar	P3 bar	Min speed rpm	Max speed rpm
XV-1 / 0,9	0,91	81,5	40,8	78	40,8	74,5	37,3	78	37,3	240	280	700	6000
XV-1 / 1,2	1,17	82,5	41,3	79	41,3	75,5	37,8	79	37,8	250	290	700	6000
XV-1 / 1,7	1,56	84	42	80,5	42	77	38,5	80,5	38,5	250	290	700	6000
XV-1 / 2,2	2,08	86	43	82,5	43	79	39,5	82,5	39,5	250	290	700	6000
XV-1 / 2,6	2,60	88	44	84,5	44	81	40,5	84,5	40,5	250	300	700	6000
XV-1 / 3,2	3,12	90	45	86	45	83	41,5	86	41,5	250	300	700	6000
XV-1 / 3,8	3,64	92	46	88,5	46	85	42,5	88,5	42,5	250	300	700	6000
XV-1 / 4,3	4,26	94	47	90,5	47	87	43,5	90,5	43,5	250	300	700	6000
XV-1 / 4,9	4,94	97	48,5	93,5	48,5	90	45	93,5	45	250	300	700	6000
XV-1 / 5,9	5,85	100,5	50,3	97	50,3	93,5	46,8	97	46,8	250	300	700	5000
XV-1 / 6,5	6,50	103	51,5	99,5	51,5	96	48	99,5	48	250	300	700	5000
XV-1 / 7,8	7,54	107	53,5	103,5	53,5	100	50	103,5	50	220	260	700	5000
XV-1 / 9,8	9,88	116	58	112,5	58	109	54,5	112,5	54,5	190	230	700	4000

TYPE	Displacem. cc/rev	M mm	M1 mm	N mm	N1 mm	O mm	O1 mm	Q mm	Q1 mm	R mm	R1 mm	P1 bar	P3 bar	Min speed rpm	Max speed rpm
XV-0 / 0,17	0,16	75,8	46,2	72,3	46,2	52,3	26,2	55,8	26,2	72,3	46,2	220	260	700	9000
XV-0 / 0,25	0,24	76,4	46,5	72,9	46,5	52,9	26,5	56,4	26,5	72,9	46,5	220	260	700	9000
XV-0 / 0,45	0,45	78	47,3	74,5	47,3	54,5	27,3	58	27,3	74,5	47,3	220	280	700	9000
XV-0 / 0,57	0,56	79	47,8	75,5	47,8	55,5	27,8	59	27,8	75,5	47,8	220	280	700	9000
XV-0 / 0,76	0,75	80,5	48,5	77	48,5	57	28,5	60,5	28,5	77	48,5	220	280	700	9000
XV-0 / 0,98	0,92	82	49,3	78,5	49,3	58,5	29,3	62	29,3	78,5	49,3	220	280	700	6000
XV-0 / 1,27	1,26	84,5	50,5	81	50,5	61	30,5	64,5	30,5	81	50,5	220	280	700	6000
XV-0 / 1,52	1,48	86,5	51,5	83	51,5	63	31,5	66,5	31,5	83	51,5	220	280	700	6000
XV-0 / 2,30	2,28	92,5	54,5	89	54,5	69	34,5	72,5	34,5	89	54,5	220	210	700	5000



MULTIPLE PUMPS – SINGLE ELEMENTS

SINGLE ELEMENTS

The catalogue is ordered by dimensional groups and connecting flanges. For each element, characterized by the connecting flange, two pages are prepared as you can see in the following picture. From the different sections it is possible to find out:

1. Structure of the Product Code corresponding to the **purchasing code** starting from the specific characteristics.
2. Typology reference – it identifies the family (primary, intermediate or final element) and the dimensional group.
3. Three-dimensional representation of the kind of product and reference to the typologies by which the assembly is possible.
4. Reference for the product identification inside the price list.
5. Product drawing and dimensions depending on the displacement.
6. Table of the variants by which it is possible to identify the product details and compose the code.

pompa trascinatrice - serie XV
POMPA TRASCINATRICE STANDARD
BASE ø30 - ALBERO CONICO

X1T

X 1 1 T 25 12 G I I A

Serie	X	serie XV
Gruppo	T	gruppo 1
Categoria	T	pompa trascinatrice
Cilindrata	25	5.8
Base	12	Ø30 STANDARD rotazione destra
Albero	G	COP20 - Conico 1.8 - ø14 - M10x1 - linguaetta sp.5
Corpo	IN	asportazione - Ø30 Ø12 M8
OUT	I	manicotto - Ø30 Ø12 M8
Coperchio	A	fermità ø25.4

XT113

TIPO	Cilindrata	Pressione Max.	CODICE	
	cm ³ /gir	P1 bar	P3 bar	
XT170.9	0,91	240	280	X 1 1 18 11 G I I A X 1 1 18 12 G I I A
XT171.2	1,17	250	290	X 1 1 17 11 G I I A X 1 1 17 12 G I I A
XT171.7	1,58	250	290	X 1 1 18 11 G I I A X 1 1 18 12 G I I A
XT172.2	2,08	250	290	X 1 1 20 11 G I I A X 1 1 20 12 G I I A
XT172.6	2,80	250	300	X 1 1 21 11 G I I A X 1 1 21 12 G I I A
XT173.2	3,12	250	300	X 1 1 23 11 G I I A X 1 1 23 12 G I I A
XT173.8	3,84	250	300	X 1 1 25 11 G I I A X 1 1 25 12 G I I A
XT174.3	4,16	250	300	X 1 1 27 11 G I I A X 1 1 27 12 G I I A
XT174.9	4,84	250	300	X 1 1 29 11 G I I A X 1 1 29 12 G I I A
XT175.9	5,85	250	300	X 1 1 31 11 G I I A X 1 1 31 12 G I I A
XT176.5	6,50	250	300	X 1 1 32 11 G I I A X 1 1 32 12 G I I A
XT177.8	7,64	220	260	X 1 1 34 11 G I I A X 1 1 34 12 G I I A
XT178.8	9,88	190	230	X 1 1 36 11 G I I A X 1 1 36 12 G I I A

P1) Pressione max. di esercizio - P3) Pressione max. di picco
 Per applicazioni gravose si consiglia di verificare la coppia ammissibile dell'albero

TIPO	Peso	A	B	D	E	F	D	E	F
	kg	mm	mm	mm	mm	mm	mm	mm	mm
XT170.9	0,950	74,5	37,3	ø12	30	M8x1	ø12	30	M8x1
XT171.2	0,970	75,5	37,8	ø12	30	M8x1	ø12	30	M8x1
XT171.7	1,010	77,0	38,5	ø12	30	M8x1	ø12	30	M8x1
XT172.2	1,030	78,0	39,5	ø12	30	M8x1	ø12	30	M8x1
XT172.6	1,080	81,0	40,5	ø12	30	M8x1	ø12	30	M8x1
XT173.2	1,090	83,0	41,5	ø12	30	M8x1	ø12	30	M8x1
XT173.8	1,120	85,0	42,5	ø12	30	M8x1	ø12	30	M8x1
XT174.3	1,170	87,0	43,5	ø12	30	M8x1	ø12	30	M8x1
XT174.9	1,200	90,0	45,0	ø12	30	M8x1	ø12	30	M8x1
XT175.9	1,280	93,5	46,8	ø12	30	M8x1	ø12	30	M8x1
XT176.5	1,300	96,0	48,0	ø12	30	M8x1	ø12	30	M8x1
XT177.8	1,360	100,0	50,0	ø12	30	M8x1	ø12	30	M8x1
XT178.8	1,500	109,0	54,5	ø12	30	M8x1	ø12	30	M8x1

T.1 = 24.4-26.4 [Nm] - coppia di serraggio viti M8
 T.2 = 119.8 [Nm] - coppia ammissibile dell'albero (N.B. Per la scelta dell'albero verificare sempre la coppia ammissibile).
 T.3 = 13 [Nm] - coppia di serraggio - chiave 17

Vivoli Oleodinamica Vivoli s.r.l. - Società a Socio Unico - via Leone Ginzburg 2-4 40054 Budrio (BO) Italy tel. +39 051 803689 fax +39 051 800061
 XT113 www.vivoli.com - italiano 15/05/2008

Tabella delle varianti

BASE ø30

BASE ø30		Tabella delle varianti				Coperchio	
Rotazione sinistra	Rotazione destra	DOP2 - Cilindrico		DOP2 - Conico		Rotazione sinistra	Rotazione destra
11	12	T.2 = 25.8 [Nm]		T.2 = 119.8 [Nm]		A	A
13	14	DOP2-HK - Cilindrico		DOP2-HK - Conico		G	G
15	16	T.2 = 25.8 [Nm]		T.2 = 119.8 [Nm]		D	D
17	18						

TIPO	CODICE
XT170.9	16
XT171.2	17
XT171.7	18
XT172.2	20
XT172.6	21
XT173.2	23
XT173.8	25
XT174.3	27
XT174.9	29
XT175.9	31
XT176.5	32
XT177.8	34
XT178.8	36

Cilindrata	sm/gir	Flettature standard				
0,9	1-1	B-B	J-J	B-Z	Z-Z	G-F
1,2	1-1	B-B	J-J	B-Z	Z-Z	G-F
1,7	1-1	B-B	J-J	B-Z	Z-Z	G-F
2,2	1-1	B-B	J-J	B-Z	Z-Z	G-F
2,6	1-1	B-B	J-J	B-Z	Z-Z	G-F
3,2	1-1	B-B	J-J	B-Z	Z-Z	G-F
3,8	1-1	B-B	J-J	B-Z	Z-Z	G-F
4,3	1-1	B-B	J-J	B-Z	Z-Z	G-F
4,9	1-1	B-B	J-J	B-Z	Z-Z	G-F
5,9	1-1	B-B	J-J	B-Z	Z-Z	G-F
6,5	1-1	B-B	J-J	B-Z	Z-Z	G-F
7,6	1-1	B-B	J-J	B-Z	Z-Z	G-F
9,8	1-1	B-B	J-J	B-Z	Z-Z	G-F

Tabella con indicate le combinazioni delle flettature e flettature standard disponibili a magazzino

1/4 BSP		3/8 BSP		1/2 BSP		M16x1.5		M18x1.5		18 UNF-2B		1/4 UNF-2B	
A	B	C	D	E	F	G	H	I	J	K	L	M	N
Corpo Chiuso													

Vivoli Oleodinamica Vivoli s.r.l. - Società a Socio Unico - via Leone Ginzburg 2-4 40054 Budrio (BO) Italy tel. +39 051 803689 fax +39 051 800061
 XT113 www.vivoli.com - italiano 15/05/2008

MULTIPLE PUMPS – SINGLE ELEMENTS



DISPLACEMENT, PRESSURES AND SPEED

	Type	Displacement	Max Pressure	Min speed	Max Speed
XV-0P	XV-0P/0.17	0.16 cm ³ /giro	260 bar	700 giri/min	9000 giri/min
	XV-0P/0.25	0.24 cm ³ /giro	260 bar	700 giri/min	9000 giri/min
	XV-0P/0.45	0.45 cm ³ /giro	280 bar	700 giri/min	9000 giri/min
	XV-0P/0.57	0.56 cm ³ /giro	280 bar	700 giri/min	9000 giri/min
	XV-0P/0.76	0.75 cm ³ /giro	280 bar	700 giri/min	9000 giri/min
	XV-0P/0.98	0.92 cm ³ /giro	280 bar	700 giri/min	6000 giri/min
	XV-0P/1.27	1.26 cm ³ /giro	280 bar	700 giri/min	6000 giri/min
	XV-0P/1.52	1.48 cm ³ /giro	280 bar	700 giri/min	6000 giri/min
	XV-0P/2.30	2.28 cm ³ /giro	210 bar	700 giri/min	5000 giri/min
XV-1P	XV-1P/0.9	0.91 cm ³ /giro	280 bar	700 giri/min	6000 giri/min
	XV-1P/1.2	1.17 cm ³ /giro	290 bar	700 giri/min	6000 giri/min
	XV-1P/1.7	1.56 cm ³ /giro	290 bar	700 giri/min	6000 giri/min
	XV-1P/2.2	2.08 cm ³ /giro	290 bar	700 giri/min	6000 giri/min
	XV-1P/2.6	2.60 cm ³ /giro	300 bar	700 giri/min	6000 giri/min
	XV-1P/3.2	3.12 cm ³ /giro	300 bar	700 giri/min	6000 giri/min
	XV-1P/3.8	3.64 cm ³ /giro	300 bar	700 giri/min	6000 giri/min
	XV-1P/4.3	4.16 cm ³ /giro	300 bar	700 giri/min	6000 giri/min
	XV-1P/4.9	4.94 cm ³ /giro	300 bar	700 giri/min	6000 giri/min
	XV-1P/5.9	5.85 cm ³ /giro	300 bar	700 giri/min	5000 giri/min
	XV-1P/6.5	6.50 cm ³ /giro	300 bar	700 giri/min	5000 giri/min
	XV-1P/7.8	7.54 cm ³ /giro	260 bar	700 giri/min	5000 giri/min
	XV-1P/9.8	9.88 cm ³ /giro	230 bar	700 giri/min	4000 giri/min
XV-2P	XV-2P/4	4.2 cm ³ /giro	300 bar	700 giri/min	3500 giri/min
	XV-2P/6	6.0 cm ³ /giro	300 bar	700 giri/min	3500 giri/min
	XV-2P/9	8.4 cm ³ /giro	300 bar	700 giri/min	3500 giri/min
	XV-2P/11	10.8 cm ³ /giro	300 bar	700 giri/min	3500 giri/min
	XV-2P/14	14.4 cm ³ /giro	290 bar	700 giri/min	3500 giri/min
	XV-2P/17	16.8 cm ³ /giro	270 bar	700 giri/min	3500 giri/min
	XV-2P/19	19.2 cm ³ /giro	250 bar	700 giri/min	3000 giri/min
	XV-2P/22	22.8 cm ³ /giro	240 bar	700 giri/min	3000 giri/min
	XV-2P/26	26.2 cm ³ /giro	210 bar	700 giri/min	3000 giri/min
	XV-2P/30	30.0 cm ³ /giro	200 bar	700 giri/min	2500 giri/min
	XV-2P/34	34.2 cm ³ /giro	190 bar	700 giri/min	2500 giri/min
	XV-2P/40	39.6 cm ³ /giro	180 bar	700 giri/min	2000 giri/min
XV-3P	XV-3P/15	14.89 cm ³ /giro	320 bar	700 giri/min	3000 giri/min
	XV-3P/18	17.37 cm ³ /giro	320 bar	700 giri/min	3000 giri/min
	XV-3P/21	21.10 cm ³ /giro	300 bar	700 giri/min	3000 giri/min
	XV-3P/27	26.97 cm ³ /giro	270 bar	700 giri/min	3000 giri/min
	XV-3P/32	32.27 cm ³ /giro	270 bar	700 giri/min	3000 giri/min
	XV-3P/38	38.47 cm ³ /giro	270 bar	700 giri/min	2800 giri/min
	XV-3P/43	43.44 cm ³ /giro	250 bar	700 giri/min	2800 giri/min
	XV-3P/47	47.16 cm ³ /giro	250 bar	700 giri/min	2800 giri/min
	XV-3P/51	50.88 cm ³ /giro	250 bar	700 giri/min	2800 giri/min
	XV-3P/54	54.60 cm ³ /giro	250 bar	700 giri/min	2300 giri/min
	XV-3P/61	60.81 cm ³ /giro	220 bar	700 giri/min	2300 giri/min
	XV-3P/64	64.53 cm ³ /giro	220 bar	700 giri/min	2300 giri/min
XV-3P/70	70.74 cm ³ /giro	210 bar	700 giri/min	2300 giri/min	
XV-3P/74	74.46 cm ³ /giro	190 bar	700 giri/min	2300 giri/min	
XV-3P/90	86.87 cm ³ /giro	160 bar	700 giri/min	2300 giri/min	

MULTIPLE PUMPS – SINGLE ELEMENTS



General technical data

Type of fluid to be used	Mineral-based hydraulic oil HLP HV (D IN 51524)
Minimum operating viscosity	10 mm ² /s
Maximum operating viscosity	100 mm ² /s
Maximum admissible viscosity at start-up	1500 mm ² /s
Recommended viscosity	20 mm ² /s - 100 mm ² /s
Ambient temperature	-20 °C - 60°C
Fluid operating temperature	-15°C - 80°C
Recommended fluid operating temperature	30°C - 50°C
For temperatures above 120°C	Request FKM seals (Viton)
Max. inlet fluid suction pressure (IN)	0.02-0.08 bars
Max. inlet fluid pressure (IN)	0.3 - 0.5 bars (for higher pressures consult the manufacturer)
Inlet fluid filtering (IN)	30 - 60 Microns
Outlet fluid filtering (OUT)	10 - 25 Microns
Max. inlet fluid speed (IN)	0.5 - 1.5 m/s
Max. outlet fluid speed (OUT)	3.0 - 5.5m/s
Use of water-glycol (HF-C)	max n. of revolutions 1100 rpm; max pressure 170 bars

Flow rate tables

TYPE	cm3/rev		rpm														Flow rate l/min		
			700	1000	1500	2000	2500	3000	3500	4000	4500	5000	5500	6000	7000	8000		9000	
XV 0P/0.17	0,16	Flow rate l/min	0,106	0,152	0,228	0,304	0,380	0,456	0,532	0,608	0,684	0,760	0,836	0,912	1,064	1,216	1,368	Flow rate l/min	
XV 0P/0.25	0,24		0,160	0,228	0,342	0,456	0,570	0,684	0,798	0,912	1,026	1,140	1,254	1,368	1,596	1,824	2,052		
XV 0P/0.45	0,45		0,299	0,428	0,641	0,855	1,069	1,283	1,496	1,710	1,924	2,138	2,351	2,565	2,993	3,420	3,848		
XV 0P/0.57	0,56		0,372	0,532	0,798	1,064	1,330	1,596	1,862	2,128	2,394	2,660	2,926	3,192	3,724	4,256	4,788		
XV 0P/0.76	0,75		0,499	0,713	1,069	1,425	1,781	2,138	2,494	2,850	3,206	3,563	3,919	4,275	4,988	5,700	6,413		
XV 0P/0.98	0,92		0,612	0,874	1,311	1,748	2,185	2,622	3,059	3,496	3,933	4,370	4,807	5,244					
XV 0P/1.27	1,26		0,838	1,197	1,796	2,394	2,993	3,591	4,190	4,788	5,387	5,985	6,584	7,182					
XV 0P/1.52	1,48		0,984	1,406	2,109	2,812	3,515	4,218	4,921	5,624	6,327	7,030	7,733	8,436					
XV 0P/2.30	2,28		1,516	2,166	3,249	4,332	5,415	6,498	7,581	8,664	9,747	10,830							

TYPE	cm3/rev		rpm											Flow rate l/min	
			700	1000	1500	2000	2500	3000	3500	4000	4500	5000	5500		6000
XV 1P/0.9	0,91	Flow rate l/min	0,630	0,900	1,350	1,800	2,250	2,700	3,150	3,600	4,050	4,500	4,950	5,400	Flow rate l/min
XV 1P/1.2	1,17		0,840	1,200	1,800	2,400	3,000	3,600	4,200	4,800	5,400	6,000	6,600	7,200	
XV 1P/1.7	1,56		1,190	1,700	2,550	3,400	4,250	5,100	5,950	6,800	7,650	8,500	9,350	10,200	
XV 1P/2.2	2,08		1,540	2,200	3,300	4,400	5,500	6,600	7,700	8,800	9,900	11,000	12,100	13,200	
XV 1P/2.6	2,6		1,820	2,600	3,900	5,200	6,500	7,800	9,100	10,400	11,700	13,000	14,300	15,600	
XV 1P/3.2	3,12		2,240	3,200	4,800	6,400	8,000	9,600	11,200	12,800	14,400	16,000	17,600	19,200	
XV 1P/3.8	3,64		2,660	3,800	5,700	7,600	9,500	11,400	13,300	15,200	17,100	19,000	20,900	22,800	
XV 1P/4.3	4,16		3,010	4,300	6,450	8,600	10,750	12,900	15,050	17,200	19,350	21,500	23,650	25,800	
XV 1P/4.9	4,94		3,430	4,900	7,350	9,800	12,250	14,700	17,150	19,600	22,050	24,500	26,950	29,400	
XV 1P/5.9	5,85		4,130	5,900	8,850	11,800	14,750	17,700	20,650	23,600	26,550	29,500			
XV 1P/6.5	6,5		4,550	6,500	9,750	13,000	16,250	19,500	22,750	26,000	29,250	32,500			
XV 1P/7.8	7,54		5,460	7,800	11,700	15,600	19,500	23,400	27,300	31,200	35,100	39,000			
XV 1P/9.8	9,88		6,860	9,800	14,700	19,600	24,500	29,400	34,300	39,200					

MULTIPLE PUMPS – SINGLE ELEMENTS



TYPE	cm3/rev		rpm							
			700	1000	1500	2000	2500	3000		
XV 2P/4	4,2	Flow rate l/min	2,800	4,000	6,000	8,000	10,000	12,000	14,000	Flow rate l/min
XV 2P/6	6		4,200	6,000	9,000	12,000	15,000	18,000	21,000	
XV 2P/9	8,4		6,300	9,000	13,500	18,000	22,500	27,000	31,500	
XV 2P/11	10,8		7,700	11,000	16,500	22,000	27,500	33,000	38,500	
XV 2P/14	14,4		9,800	14,000	21,000	28,000	35,000	42,000	29,000	
XV 2P/17	16,8		11,900	17,000	25,500	34,000	42,500	51,000	59,500	
XV 2P/19	19,2		13,300	19,000	28,500	38,000	47,500	57,000		
XV 2P/22	22,8		15,400	22,000	33,000	44,000	55,000	66,000		
XV 2P/26	26,2		18,200	26,000	39,000	52,000	65,000	78,000		
XV 2P/30	30		21,000	30,000	45,000	60,000	75,000			
XV 2P/34	34,2		23,800	34,000	51,000	68,000	85,000			
XV 2P/40	39,6		28,000	40,000	60,000	80,000				

TYPE	cm3/rev		rpm							
			700	1000	1500	2000	2300	2500		
XV 3P/15	14,89	Flow rate l/min	9,90	14,15	21,22	28,29	32,54	35,37	42,44	Flow rate l/min
XV 3P/18	17,37		11,55	16,51	24,76	33,01	37,96	41,26	49,52	
XV 3P/21	21,10		14,03	20,04	30,06	40,08	46,10	50,11	60,13	
XV 3P/27	26,97		17,94	25,62	38,43	51,24	58,93	64,05	76,86	
XV 3P/32	32,27		21,46	30,65	45,98	61,31	70,50	76,63	91,96	
XV 3P/38	38,47		25,58	36,55	54,82	73,09	84,06	91,37		
XV 3P/43	43,44		28,88	41,26	61,89	82,53	94,91	103,16		
XV 3P/47	47,16		31,36	44,80	67,20	89,60	103,04	112,00		
XV 3P/51	50,88		33,84	48,34	72,51	96,67	111,17			
XV 3P/54	54,60		36,31	51,87	77,81	103,75	119,31			
XV 3P/61	60,81		40,44	57,77	86,65	115,54	132,87			
XV 3P/64	64,53		42,91	61,31	91,96	122,61	141,00			
XV 3P/70	70,74		47,04	67,20	100,80	134,40	154,56			
XV 3P/74	74,46		49,52	70,74	106,11	141,47	162,70			
XV 3P/90	86,87		57,77	82,53	123,79	165,05	189,81			

MULTIPLE PUMPS – SINGLE ELEMENTS



XV-0P CHARACTERISTIC FLOW RATE CURVES

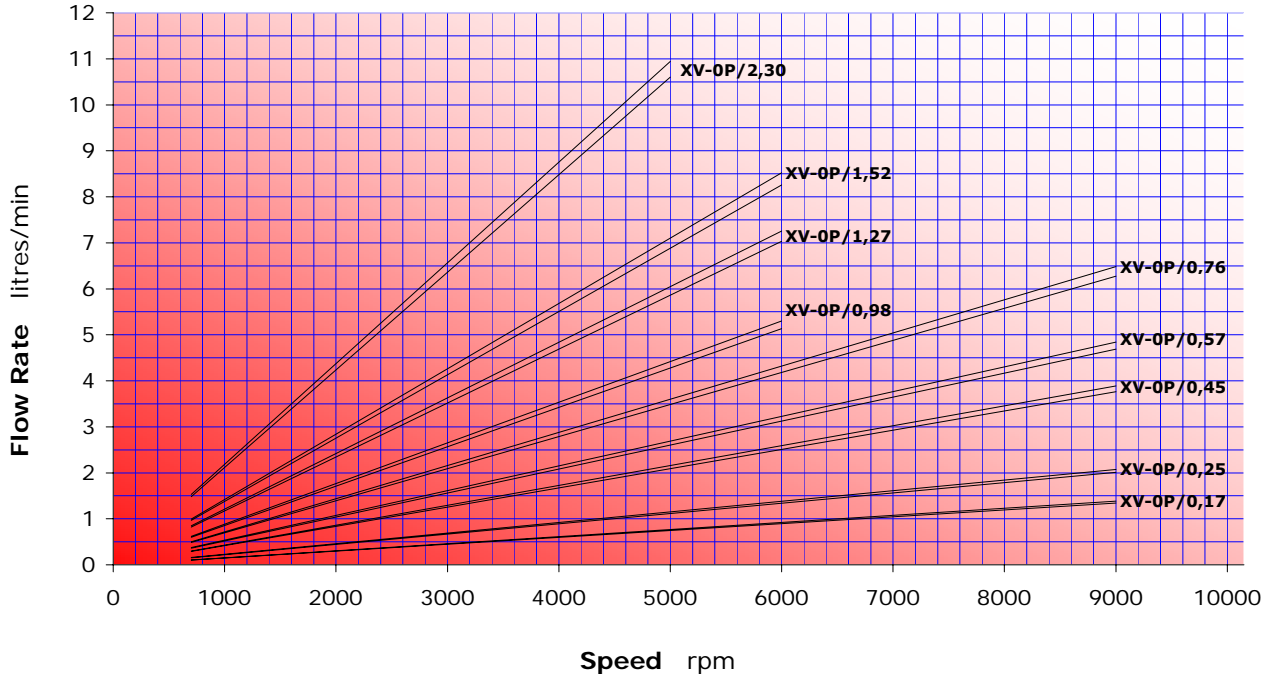

XV-0P MOTOR TORQUE

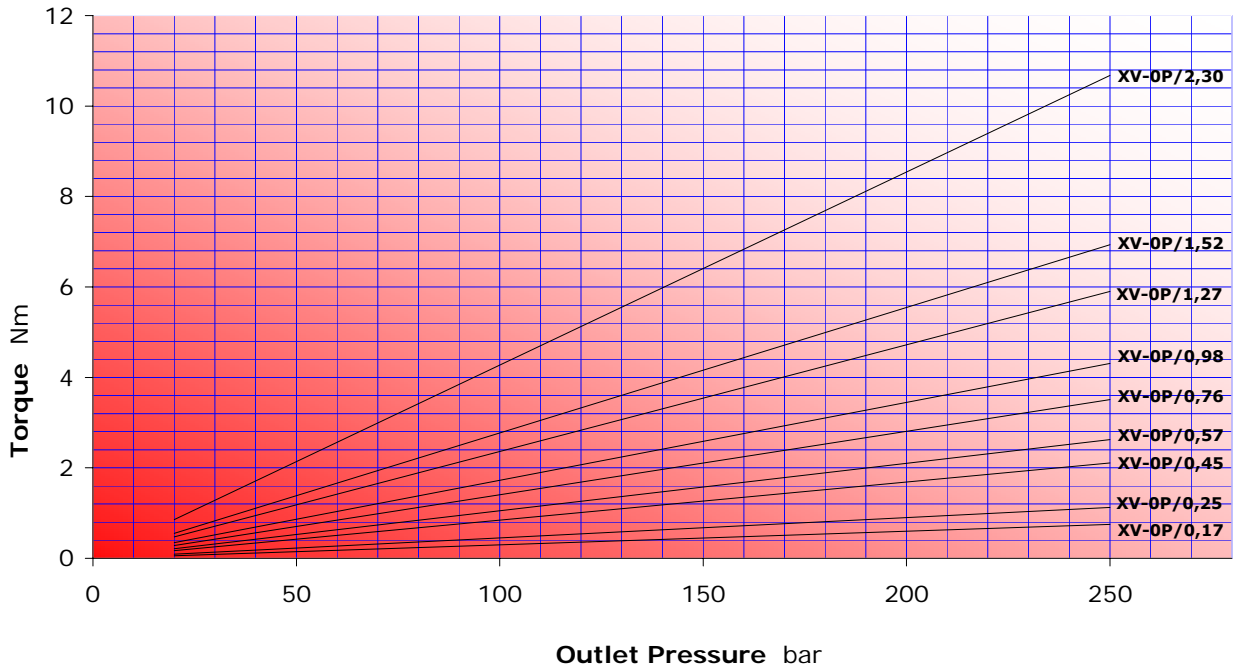

MULTIPLE PUMPS – SINGLE ELEMENTS



XV-2P CHARACTERISTIC FLOW RATE CURVES

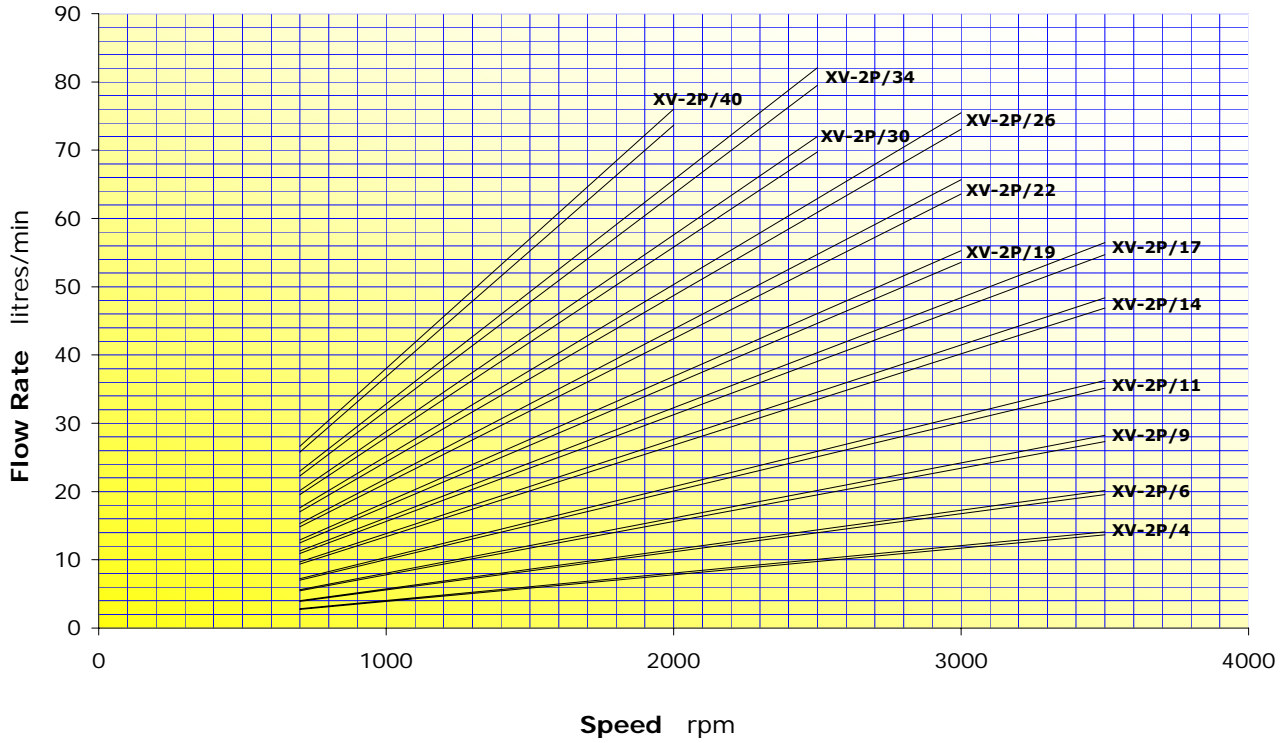

XV-2P MOTOR TORQUE

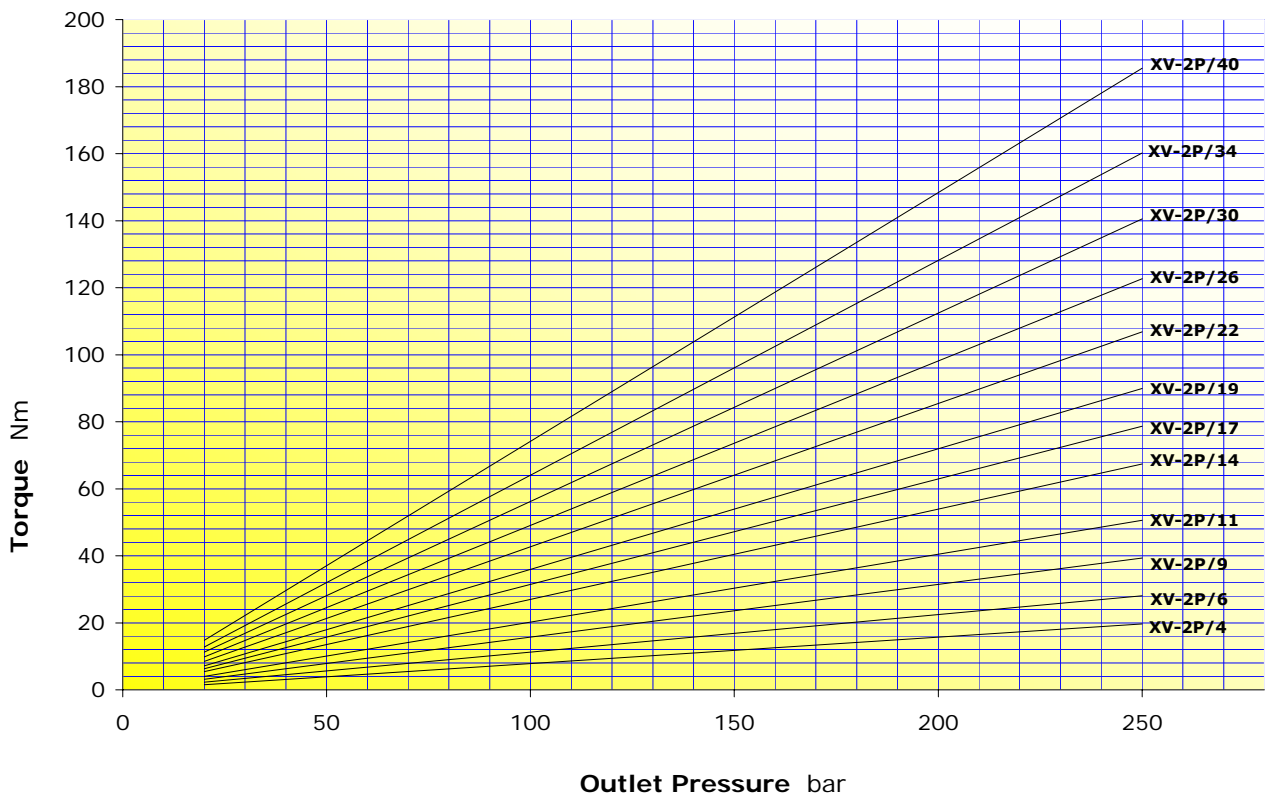

MULTIPLE PUMPS – SINGLE ELEMENTS



XV-3P CHARACTERISTIC FLOW RATE CURVES

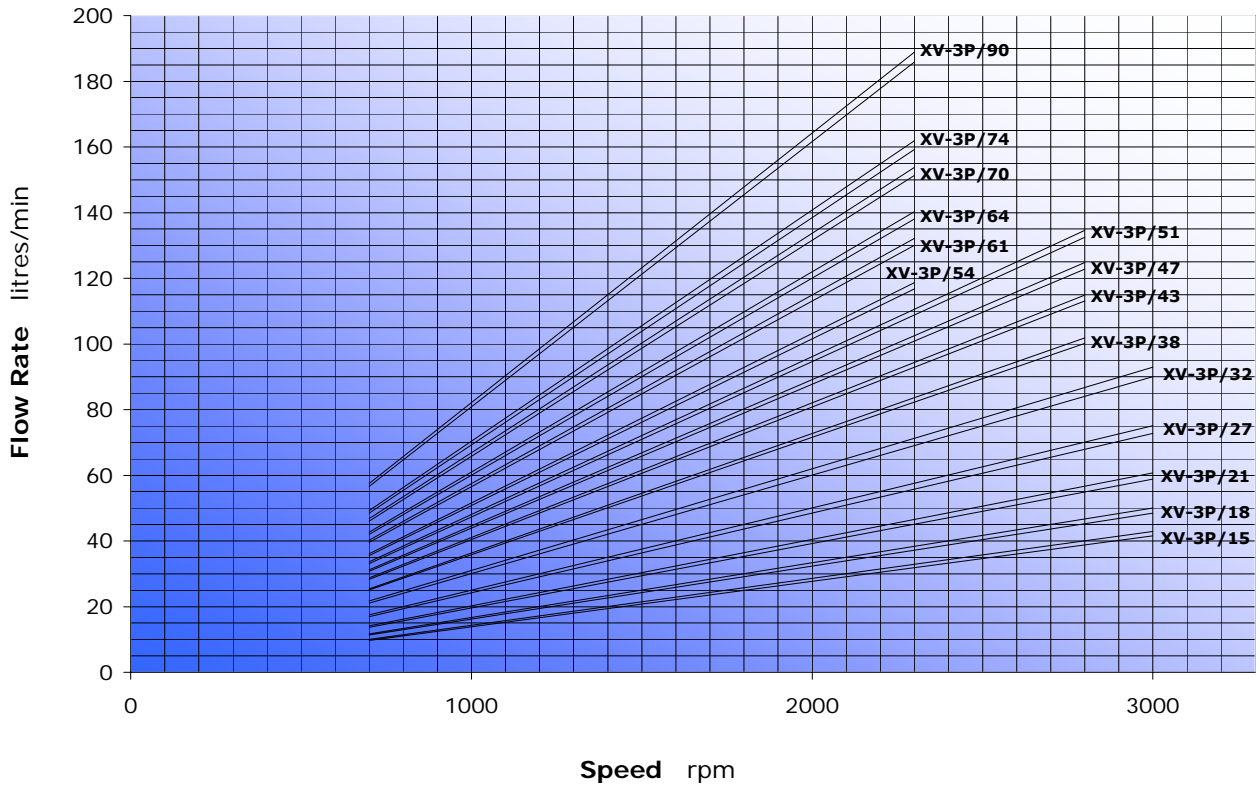

XV-3P MOTOR TORQUE

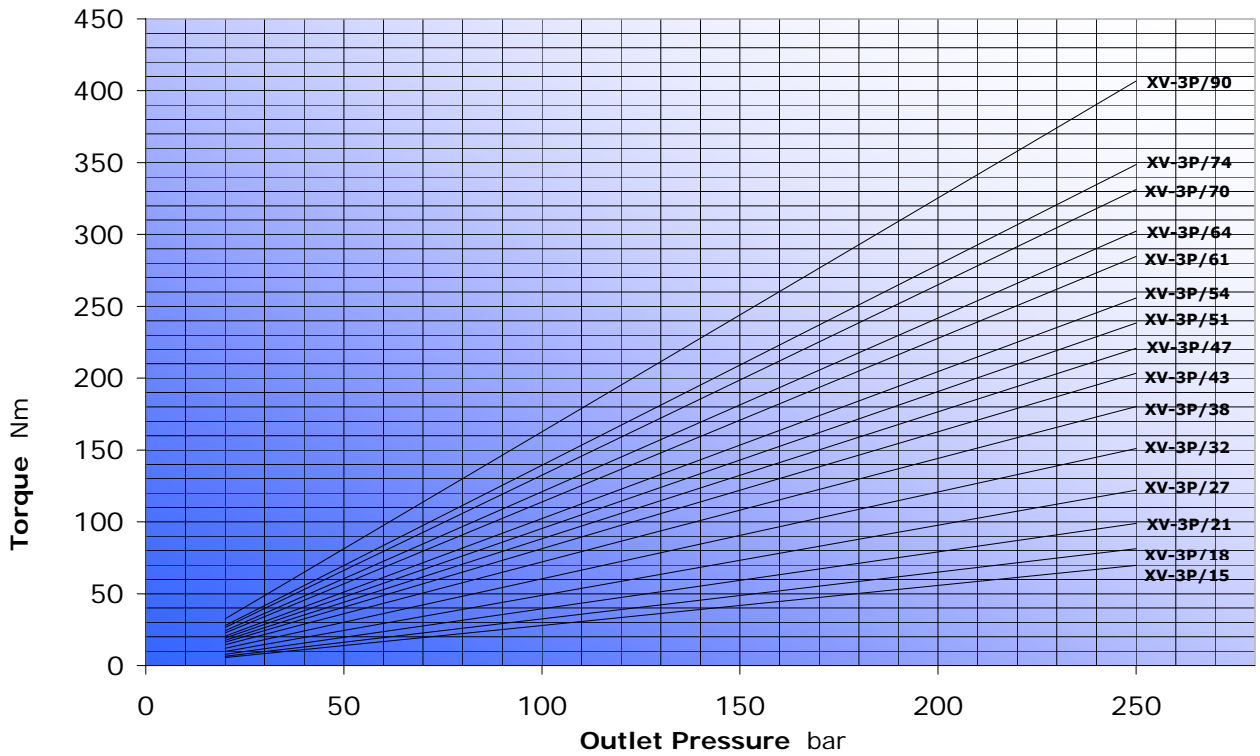

MULTIPLE PUMPS – SINGLE ELEMENTS



Constructive features

PART	MATERIAL	MECHANICAL FEATURES
PUMP BODY	Extruded alloy Series 7000, heat treated and anodised	$R_p = 345 \text{ N/mm}^2$ (Yield strength) $R_m = 382 \text{ N/mm}^2$ (Breaking strength)
FLANGE AND COVER	Die-cast aluminium alloy with excellent mechanical features, heat treated and anodised	$R_p = 310\div 350 \text{ N/mm}^2$ (Yield strength) $R_m = 350\div 400 \text{ N/mm}^2$ (Breaking strength)
GEAR BUSH BEARINGS	Special heat-treated tin alloy with excellent mechanical features and high anti-friction capacity. Self-lubricating bushes DU	$R_p = 350 \text{ N/mm}^2$ (Yield strength) $R_m = 390 \text{ N/mm}^2$ (Breaking strength)
GEARS	Steel UNI 7846	$R_s = 980 \text{ N/mm}^2$ (Yield strength) $R_m = 1270\div 1570 \text{ N/mm}^2$ (Breaking strength)
SEALS	A 727 Standard Acrylonitrile F 975 Viton FKM	70 Shore, thermal resistance 120°C 80 Shore, thermal resistance 200°C
BACK-UP RINGS	Virgin PTFE Tecnil Q3	

MULTIPLE PUMPS – SINGLE ELEMENTS

LINKING KIT

To assemble multiple pump starting from single element (driving, intermediate and final pump), dedicated linking kit are required. They can be chosen starting from the dimensional group of the elements to be assembled. Currently no linking kit are available for separated stage or common inlet solutions.

In the following pages you can find the available Kit, their content and how they should be applied.

Accoppiamento - Linking (Cod.: 8KITR001)

OP + OP

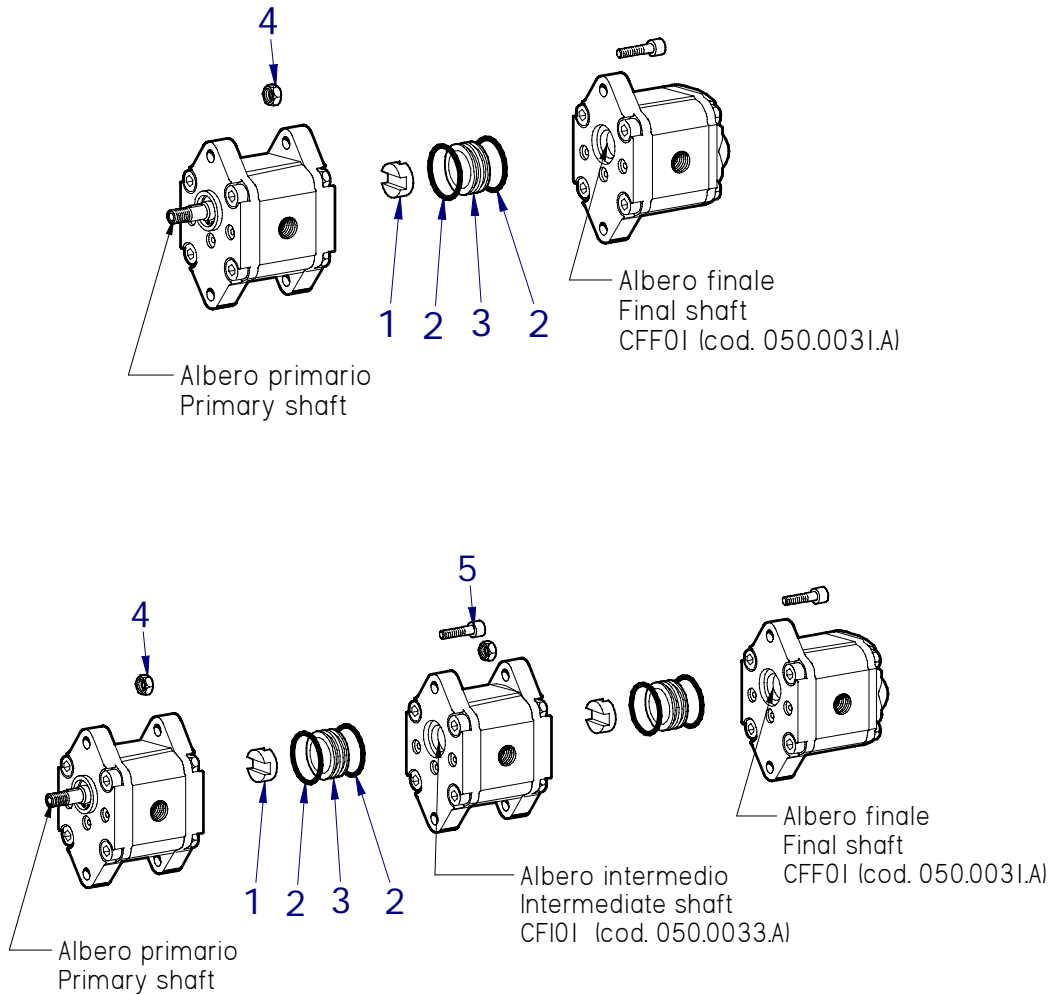

KIT ACCOPPIAMENTO WV 0P+0P LINKING KIT WV 0P+0P				Cod.: 8KITR001
Pos.	Code	Qt. à	Descrizione	Description
1	050.0070.A	1	Giunto a croce	Slider coupling
2	640.0025.A	2	OR 18,77 x 1,78	OR 18,77 x 1,78
3	050.0106.A	1	Anello di centraggio	Centering ring
4	540.0030.A	2	Dado M6 H=6	Nut M6 H=6
5	521.0006.AL025	2	Vite TCCE M6 x 25	Screw TCCE M6 x 25

MULTIPLE PUMPS – SINGLE ELEMENTS



Accoppiamento– Linking (Cod.: 8KITR002)

1P + 1P

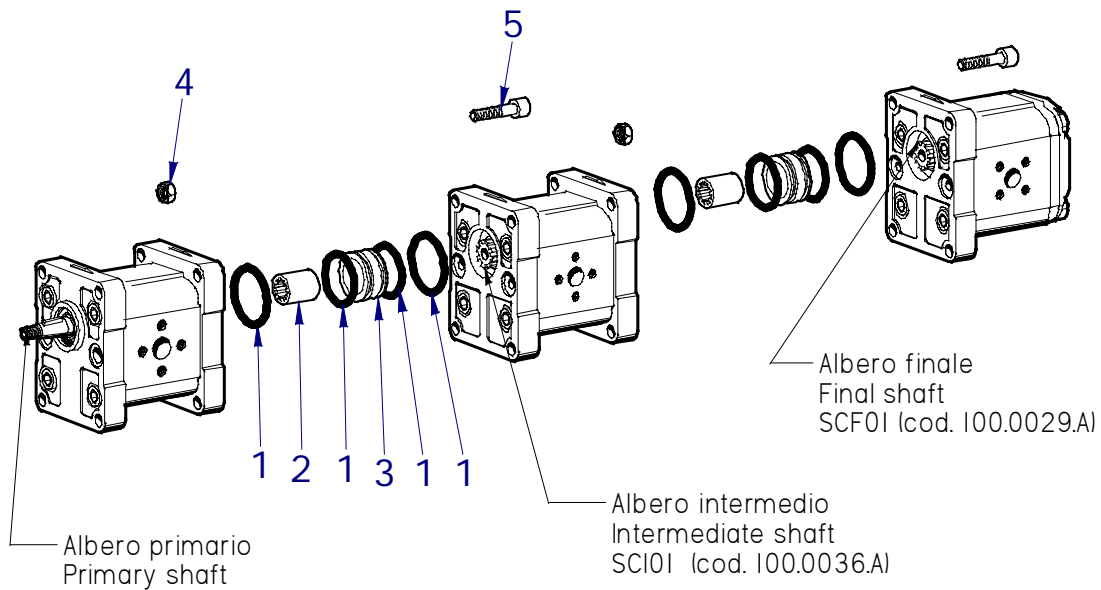
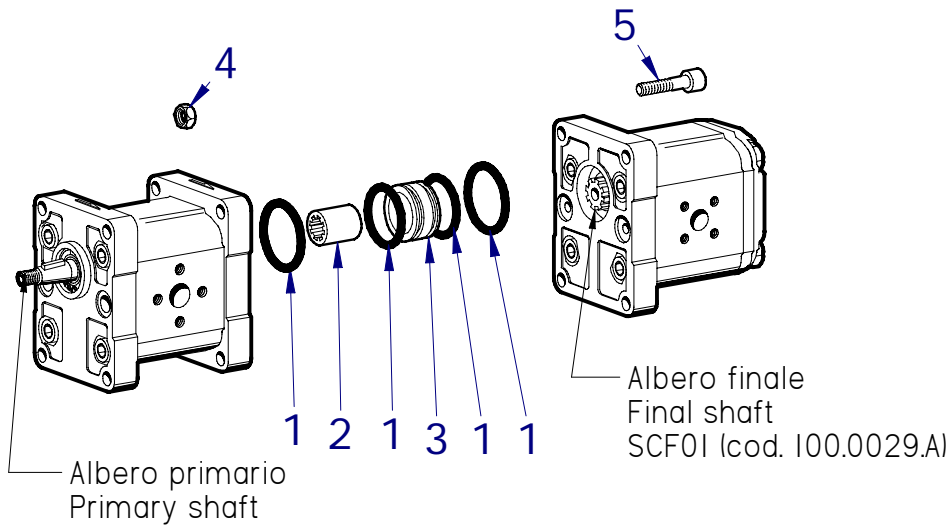

KIT ACCOPIAMENTO XV 1P+1P LINKING KIT XV 1P+1P				Cod.: 8KITR002
Pos.	Code	Qt.à	Descrizione	Description
1	640.0030.A	4	OR 21.95 x1.78	OR 21.95 x1.78
2	100.0058.A	1	Manicotto scanalato	Grooved sleeve
3	100.0082.A	1	Anello di centraggio	Centering ring
4	540.0030.A	4	Dado M6 H=6	Nut M6 H=6
5	521.0006.AL035	4	Vite TCCE M6 x 35	Screw TCCE M6 x 35

MULTIPLE PUMPS – SINGLE ELEMENTS



Accoppiamento– Linking (Cod.: 8KITR003 - 8KITR007) **1P + 0P**

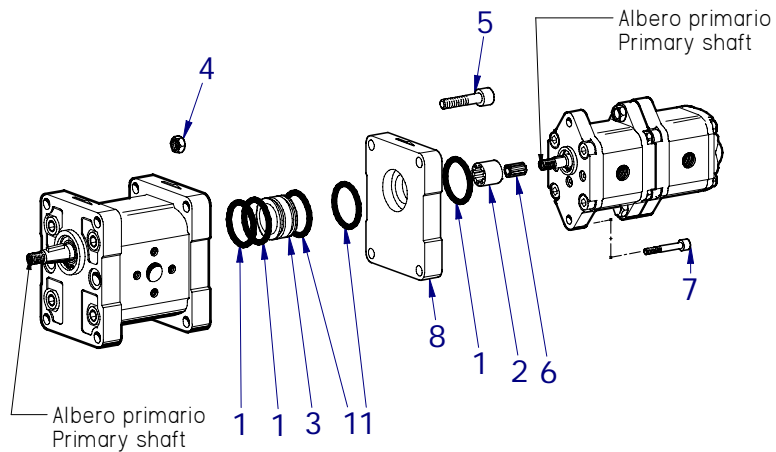
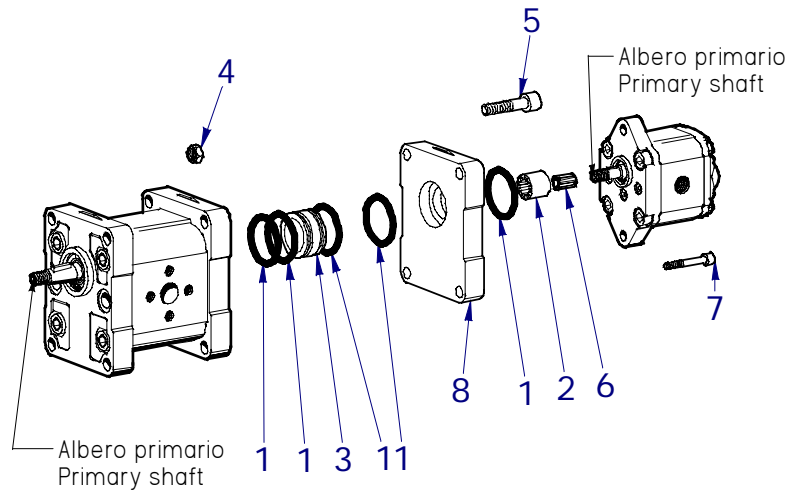

KIT ACCOPPIAMENTO XV 1P+0P LINKING KIT XV 1P+ 0P				Cod.: 8KITR003
Pos.	Code	Qt.à	Descrizione	Description
1	640.0030.A	5	OR 21.95x1.78	OR 21.95x1.78
2	100.0091.A	1	Manicotto scanalato	Grooved sleeve
3	100.0082.A	1	Anello di centraggio	Centering ring
4	540.0030.A	4	Dado M6 H=6	Nut M6 H=6
5	521.0006.AL035	4	Vite TCCE M6 x 35	Screw TCCE M6 x 35
6	050.0040.A	1	Manicotto scanalato	Grooved sleeve
7	521.0006.AL025	2	Vite TCCE M6 x 25	Screw TCCE M6 x 25

KIT ACCOPPIAMENTO XV 1P+0P con flangia di supporto LINKING KIT XV 1P+ 0P with mounting flange				Cod.: 8KITR007
Pos.	Code	Qt.à	Descrizione	Description
	8KITR003	1	KIT 1P+0P	KIT 1P+0P
8	100.0044.A	1	flangia di supporto 1P+0P	1P+0P mounting flange

MULTIPLE PUMPS – SINGLE ELEMENTS



Accoppiamento– Linking Cod.: (8KITR004)

2P + 2P

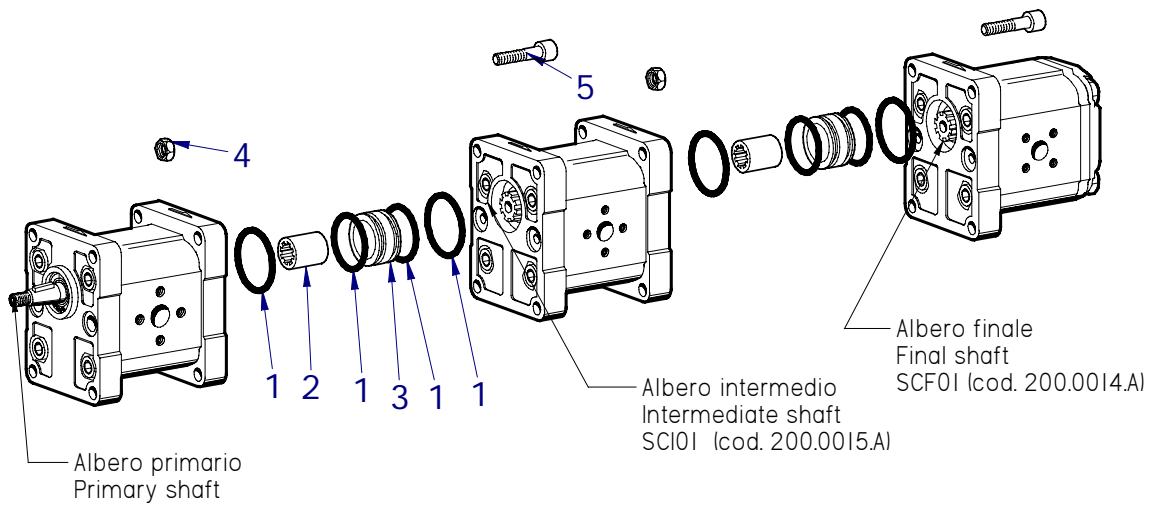
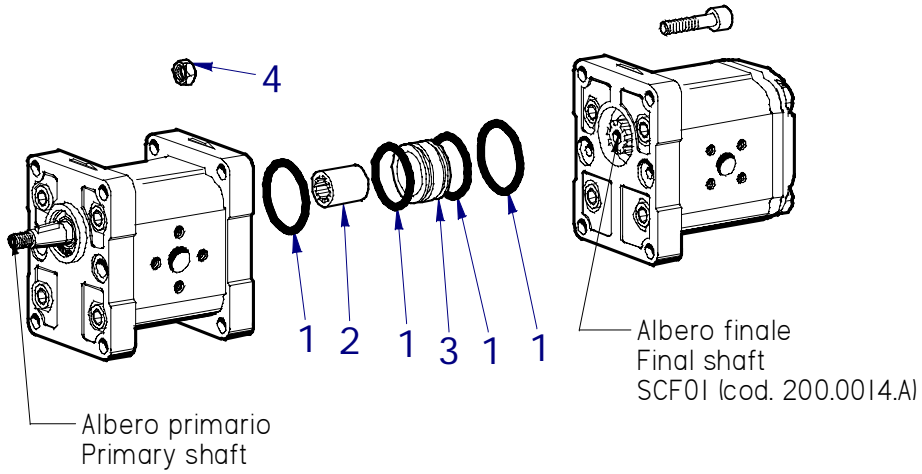

KIT ACCOPPIAMENTO XV 2P + 2P LINKING KIT XV 2P + 2P				Cod.: 8KITR004
Pos.	Code	Qt.à	Descrizione	Description
1	640.0045.A	4	OR 33.05x1.78	OR 33.05x1.78
2	200.0019.B	1	Manicotto scanalato	Grooved sleeve
3	200.0065.A	1	Anello di centraggio	Centering ring
4	540.0045.A	4	Dado M8 H=8	Nut M8 H=8
5	521.0008.AL35	4	Vite TCCE M8 x 35	Screw TCCE M8 x 35

MULTIPLE PUMPS – SINGLE ELEMENTS

Accoppiamento – Linking (Cod.: 8KITR005)

2P + 1P

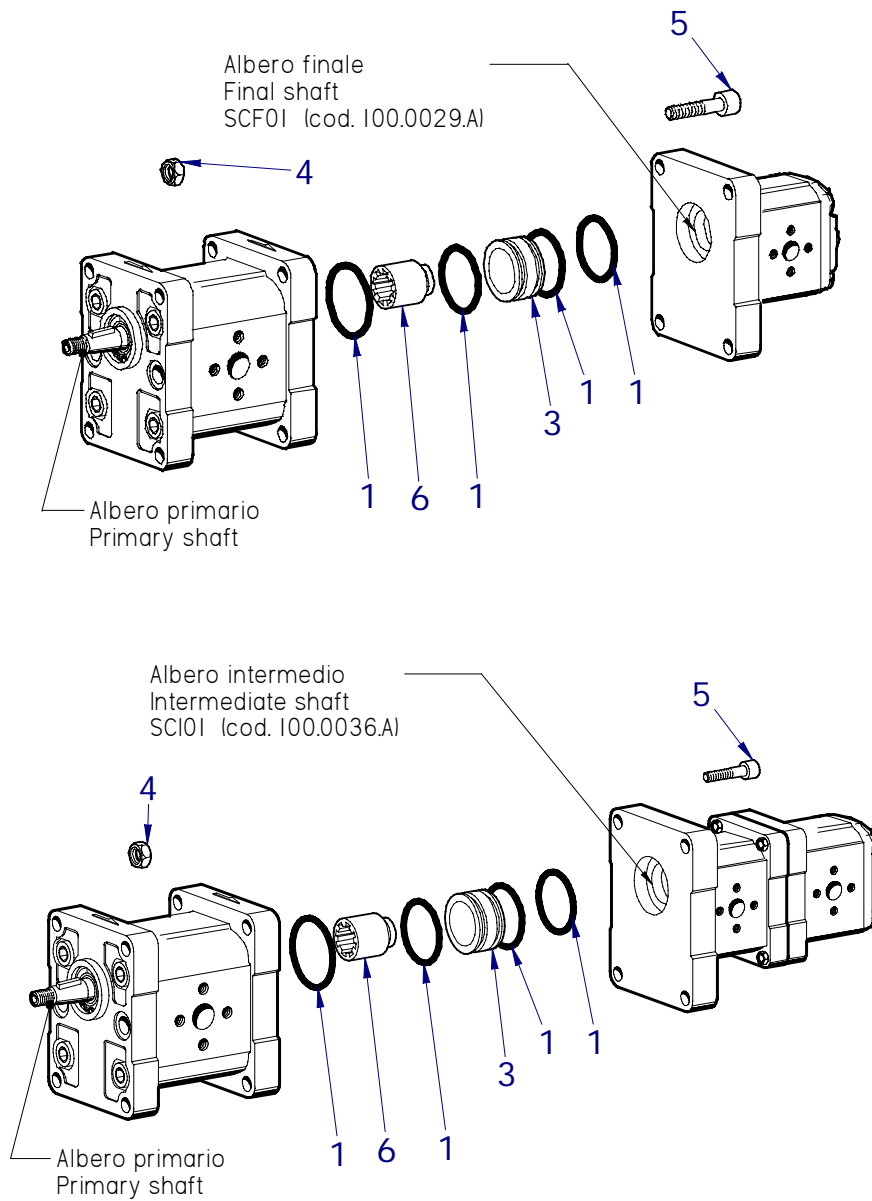

KIT ACCOPPIAMENTO XV 2P + 1P LINKING KIT XV 2P + 1P				Cod.: 8KITR005
Pos.	Code	Qt.à	Descrizione	Description
1	640.0045.A	4	OR 33.05x1.78	OR 33.05x1.78
3	200.0065.A	1	Anello di centraggio	Centering ring
4	540.0045.A	4	Dado M8 H=8	Nut M8 H=8
5	521.0008.AL035	4	Vite TCCE M8 x 35	Screw TCCE M8 x 35
6	200.0046.A	1	Manicotto scanalato	Grooved sleeve

MULTIPLE PUMPS – SINGLE ELEMENTS

Accoppiamento – Linking (Cod.: 8KITR006 - 8KITR008) **2P** + **0P**

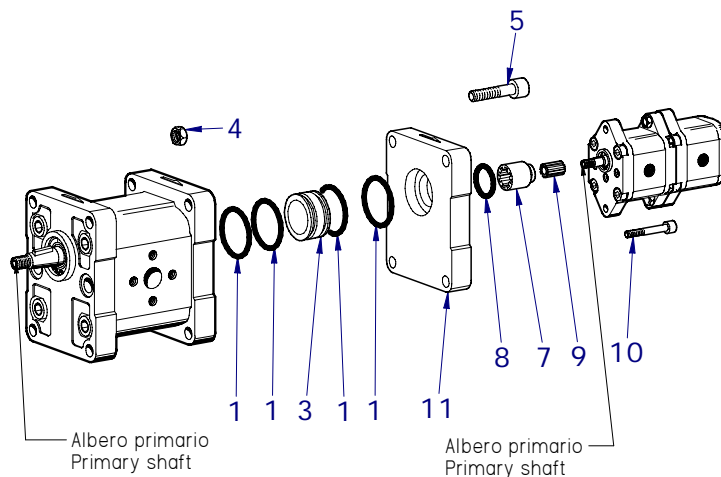
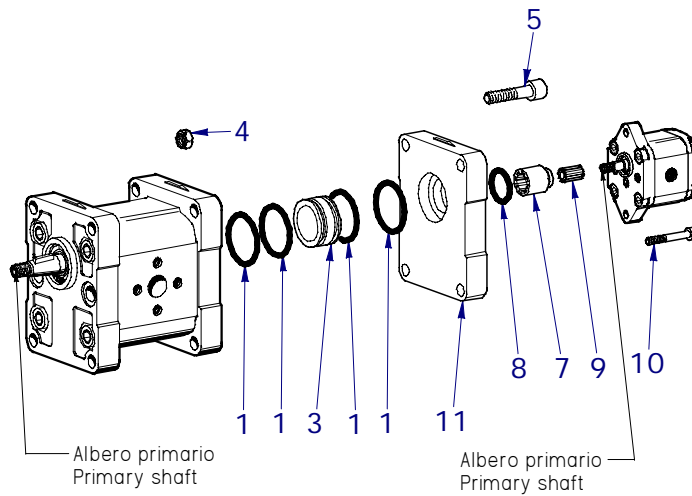

KIT ACCOPPIAMENTO XV 2P + 0P LINKING KIT XV 2P + 0P				Cod.: 8KITR006
Pos.	Code	Qt.à	Descrizione	Description
1	640.0045.A	4	OR 33.05x1.78	OR 33.05x1.78
3	200.0065.A	1	Anello di centraggio	Centering ring
4	540.0045.A	4	Dado M8 H=8	Nut M8 H=8
5	521.0008.AL040	4	Vite TCCE M8 x 40	Screw TCCE M8 x 40
7	200.0162.A	1	Manicotto scanalato	Grooved sleeve
8	640.0030.A	1	OR 21.95 x 1.78	OR 21.95 x 1.78
9	050.0040.A	1	Manicotto scanalato	Grooved sleeve
10	521.0006.AL025	2	Vite TCCE M6 x 25	Screw TCCE M6 x 25

KIT ACCOPPIAMENTO XV 2P+0P con flangia di supporto LINKING KIT XV 2P+ 0P with mounting flange				Cod.: 8KITR008
Pos.	Code	Qt.à	Descrizione	Description
	8KITR006	1	KIT 2P+0P	KIT 2P+0P
11	200.0170.A	1	flangia di supporto 2P+0P	2P+0P mounting flange

MULTIPLE PUMPS – SINGLE ELEMENTS

Accoppiamento – Linking (Cod: 8KITR013) **3P + 3P**

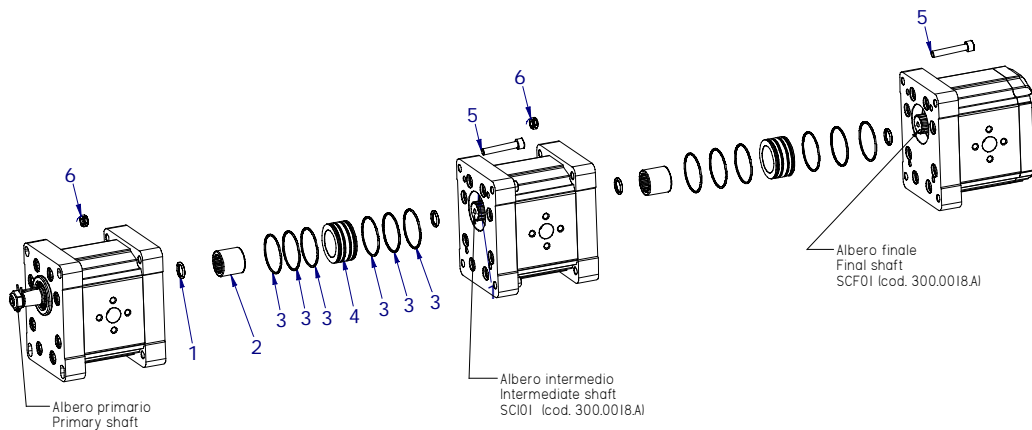
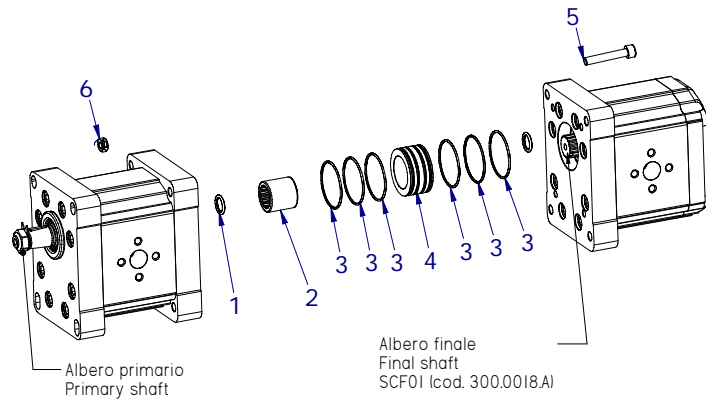

KIT ACCOPPIAMENTO XV 3P + 3P LINKING KIT XV 3P + 3P				Cod.: 8KITR013
Pos.	Code	Qt.à	Descrizione	Description
1	650.0015.A	2	OR 18.72 x 2.62	OR 18.72 x 2.62
2	300.0019.A	1	Manicotto scanalato	Grooved sleeve
3	640.0085.A	6	OR 47.35 x 1.78	OR 47.35 x 1.78
4	300.0012.A	1	Anello di centraggio	Centering ring
5	521.0008.AL055	4	Vite TCCE M8 x 55	Screw TCCE M8 x 55
6	540.0045.A	4	Dado M8 H=8	Nut M8 H=8

MULTIPLE PUMPS – SINGLE ELEMENTS

Accoppiamento– Linking (Cod.: 8KITR012) **3P** + **2P**

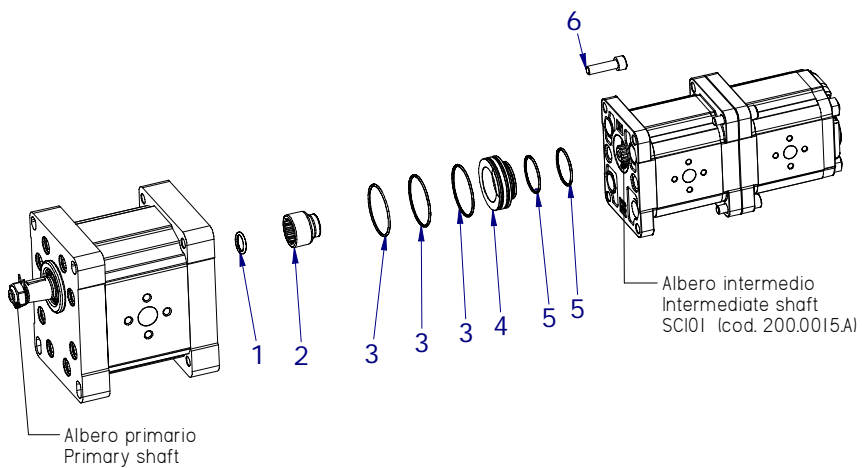
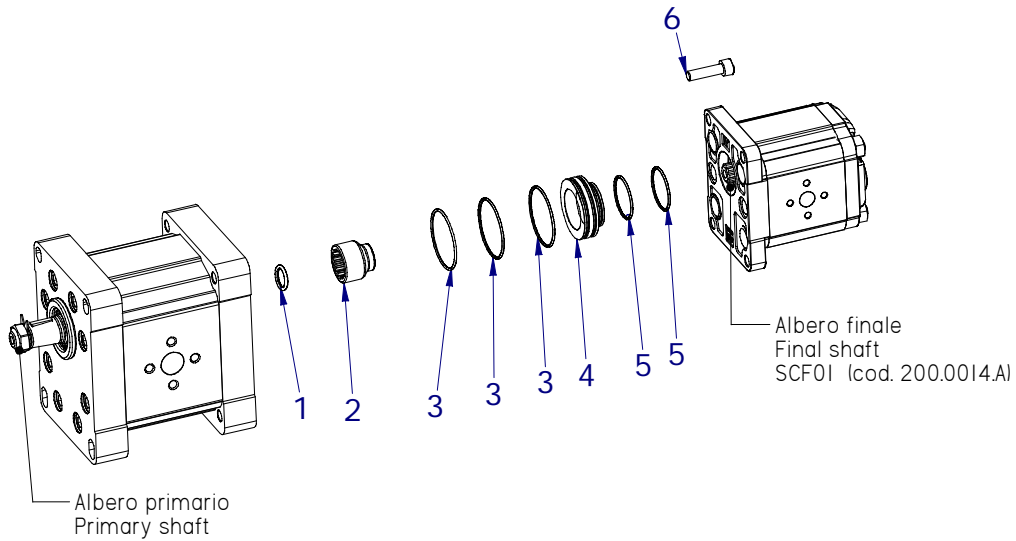

KIT ACCOPIAMENTO XV 3P + 2P LINKING KIT XV 3P + 2P				Cod.: 8KITR012
Pos.	Code	Qt.à	Descrizione	Description
1	650.0015.A	1	OR 18.72 x 2.62	OR 18.72 x 2.62
2	300.0021.A	1	Manicotto scanalato	Grooved sleeve
3	640.0085.A	3	OR 47.35 x 1.78	OR 47.35 x 1.78
4	300.0020.A	1	Anello di centraggio	Centering ring
5	640.0045.A	2	OR 33.05 x 1.78	OR 33.05 x 1.78
6	521.0008.AL25	4	Vite TCCE M8 x 25	Screw TCCE M8 x 25

MULTIPLE PUMPS – SINGLE ELEMENTS



Accoppiamento – Linking (Cod.: 8KITR011)

3P + 1P

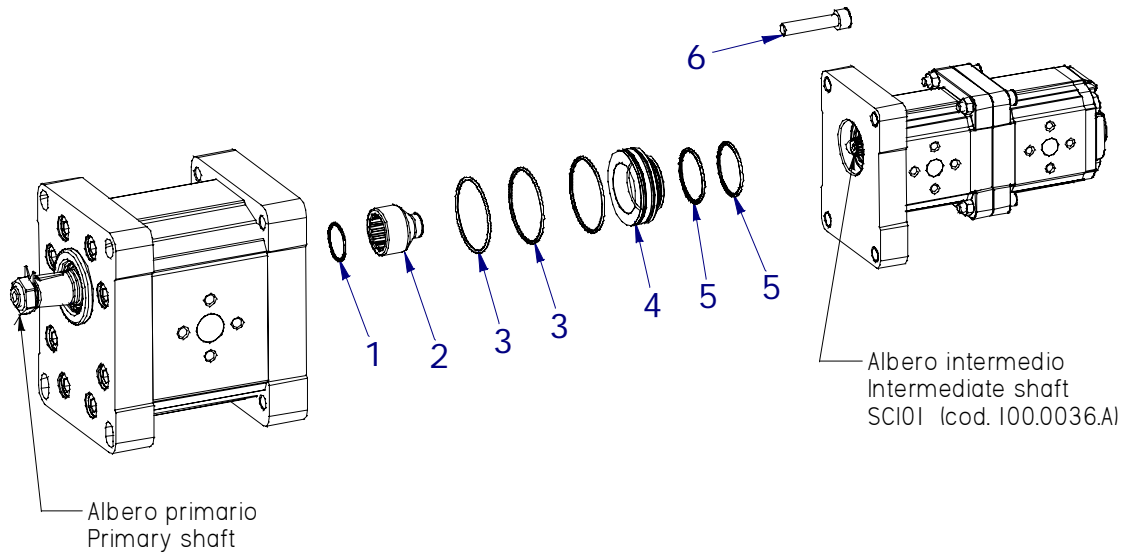
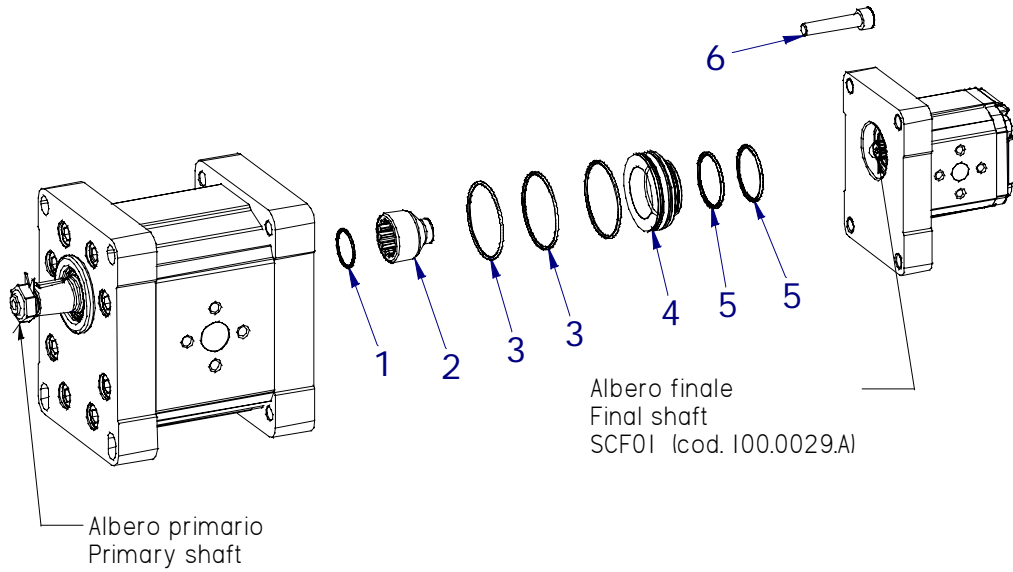

KIT ACCOPPIAMENTO XV 3P + 1P LINKING KIT XV 3P + 1P				Cod.: 8KITR011
Pos.	Code	Qt.à	Descrizione	Description
1	650.0015.A	2	OR 18.72 x 2.62	OR 18.72 x 2.62
2	300.0022.A	1	Manicotto scanalato	Grooved sleeve
3	640.0085.A	3	OR 47.35 x 1.78	OR 47.35 x 1.78
4	300.0020.A	1	Anello di centraggio	Centering ring
5	640.0045.A	2	OR 33.05 x 1.78	OR 33.05 x 1.78
6	521.0008.AL35	4	Vite TCCE M8 x 35	Screw TCCE M8 x 35

MULTIPLE PUMPS – SINGLE ELEMENTS



Accoppiamento– Linking (Cod.: 8KITR009- 8KITR015) **3P** + **0P**

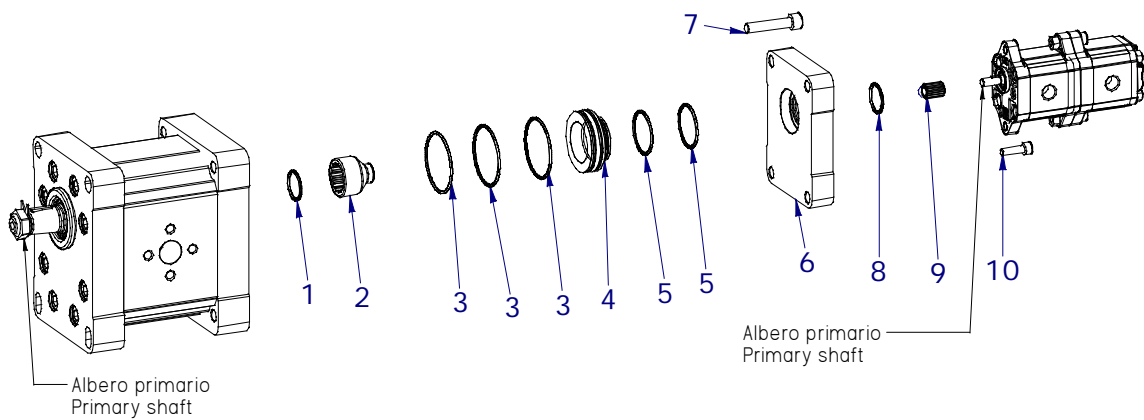
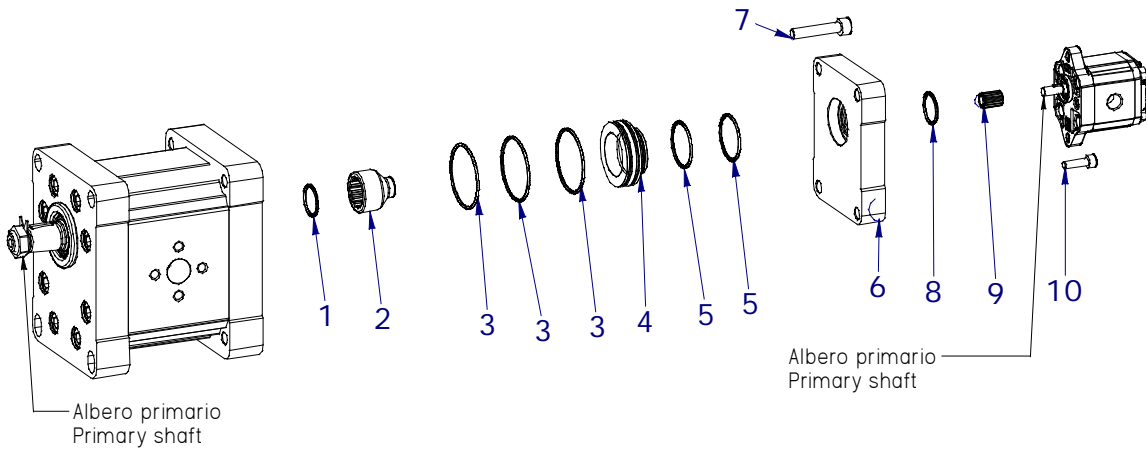

KIT ACCOPPIAMENTO XV 3P + 0P LINKING KIT XV 3P + 0P				Cod.: 8KITR009
Pos.	Code	Qt.à	Descrizione	Description
1	650.0015.A	2	OR 18.72 x 2.62	OR 18.72 x 2.62
2	300.0022.A	1	Manicotto scanalato	Grooved sleeve
3	640.0085.A	3	OR 47.35 x 1.78	OR 47.35 x 1.78
4	300.0020.A	1	Anello di centraggio	Centering ring
5	640.0045.A	2	OR 33.05 x 1.78	OR 33.05 x 1.78
7	521.0008.AL35	4	Vite TCCE M8 x 35	Screw TCCE M8 x 35
8	640.0030.A	1	OR 21.95 x 1.78	OR 21.95 x 1.78
9	050.0040.A	1	Manicotto scanalato	Grooved sleeve
10	521.0006.AL25	2	Vite TCCE M6 x 25	Screw TCCE M6 x 25

KIT ACCOPPIAMENTO XV3P+0P con flangia di supporto LINKING KIT XV 3P+ 0P with mounting flange				Cod.: 8KITR015
Pos.	Code	Qt.à	Descrizione	Description
	8KITR009	1	KIT 3P+0P	KIT 3P+0P
6	200.0170.A	1	flangia di supporto 2P+0P	2P+0P mounting flange

entrainment pump - series XV

XOT

STANDARD DRIVING PUMP
 ø22 FLANGE - PARALLEL SHAFT

X 0 T 06 02 A B B A

Series	X	series XV
Group	0	group 0
Category	T	entrainment pump
Displacement	06	0.76
Flange	02	Ø22 right rotation
Shaft	A	CIP01 - Parallel ø7 - M7x1 - key thk. 2
Body	IN	inlet - 1/4" GAS
	OUT	outlet - 1/4" GAS
Cover	A	ø22 female cover for left multiple pump element

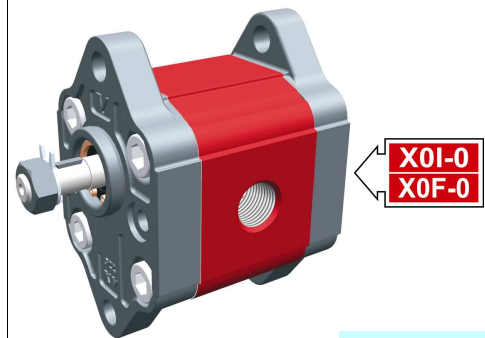

XT001

Technical data table						
TYPE	Displacement cm3/rev	Max. Pressure		CODE		
		P1 bar	P3 bar	Left rotation		Right rotation
XOT/0.17	0,16	220	260	X 0 T 01 01 A B B A	X 0 T 01 02 A B B A	X 0 T 01 02 A B B A
XOT/0.25	0,24	220	260	X 0 T 02 01 A B B A	X 0 T 02 02 A B B A	X 0 T 02 02 A B B A
XOT/0.45	0,45	220	280	X 0 T 04 01 A B B A	X 0 T 04 02 A B B A	X 0 T 04 02 A B B A
XOT/0.57	0,56	220	280	X 0 T 05 01 A B B A	X 0 T 05 02 A B B A	X 0 T 05 02 A B B A
XOT/0.76	0,75	220	280	X 0 T 06 01 A B B A	X 0 T 06 02 A B B A	X 0 T 06 02 A B B A
XOT/0.98	0,92	220	280	X 0 T 07 01 A B B A	X 0 T 07 02 A B B A	X 0 T 07 02 A B B A
XOT/1.27	1,26	220	280	X 0 T 09 01 A B B A	X 0 T 09 02 A B B A	X 0 T 09 02 A B B A
XOT/1.52	1,48	220	280	X 0 T 11 01 A B B A	X 0 T 11 02 A B B A	X 0 T 11 02 A B B A
XOT/2.30	2,28	190	210	X 0 T 13 01 A B B A	X 0 T 13 02 A B B A	X 0 T 13 02 A B B A

P1) Max. working pressure - P3) Max. peak pressure

For heavy-duty applications, it is recommended to check the admissible torque of the shaft

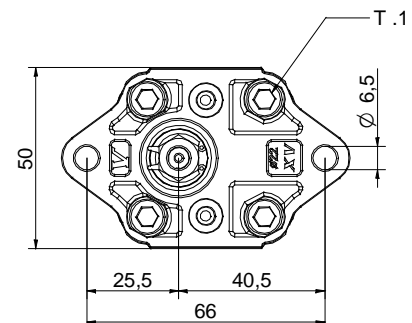
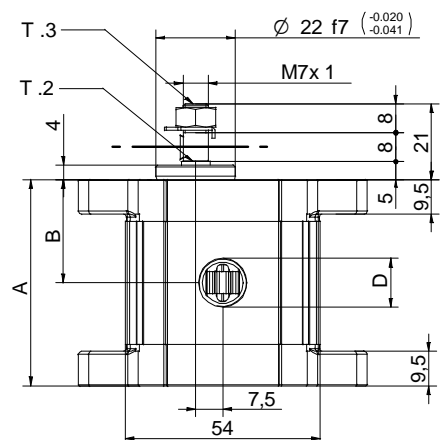
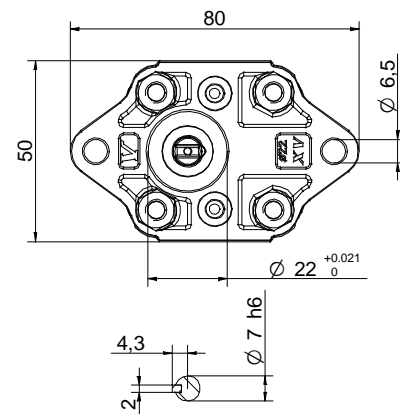

3103/08 XOT0602ABBA.dft

T.1 = 11.7÷13.7 [Nm] - screw tightening torque M6

T.3 = 11.5 [Nm] - torque wrench setting 11

T.2 = 2.1 [Nm] - admissible shaft torque (N.B. When choosing a shaft, always check the admissible torque).

Table of variations

XOT

Standard ø22 FLANGE

Standard ø22 FLANGE				Shaft				Cover			
Left rotation		Right rotation						Left rotation		Right rotation	
	01		02	CIP01 - Parallel T.2 = 2.1 [Nm]	A	CFP01 - Milled shank T.2 = 9.2 [Nm]	B				A
	03		04	CF005 - Milled shank T.2 = 8.4 [Nm]	F	CO001 - Tapered T.2 = 21.9 [Nm]	E				D
	05		06								
	07		08								

Displacement	
TYPE	CODE
XOT/0.17	01
XOT/0.25	02
XOT/0.45	04
XOT/0.57	05
XOT/0.76	06
XOT/0.98	07
XOT/1.27	09
XOT/1.52	11
XOT/2.30	13

Standard bodies			
Displacement cm3/rev	Standard threads		
	0.17	B - B	Z - B
0.25	B - B	Z - B	Z - Z
0.45	B - B	Z - B	Z - Z
0.57	B - B	Z - B	Z - Z
0.76	B - B	Z - B	Z - Z
0.98	B - B	Z - B	Z - Z
1.27	B - B	Z - B	Z - Z
1.52	B - B	Z - B	Z - Z
2.30	B - B	Z - B	Z - Z

Table showing standard flange and thread combinations available in stock

Body (threads/flanges)													
	A		B		C		D		E		F		G
	H		I	Closed Body	Z								

entrainment pump - series XV

XOT

"BH" DRIVING PUMP
 ø22 BODY-SHAPED FLANGE - MILLED SHANK

X 0 T 06 12 B B B A

Series	X	series XV
Group	0	group 0
Category	T	entrainment pump
Displacement	06	0.76
Flange	12	Ø22 BH right rotation
Shaft	B	CFP01 - Milled shank ø7 - thk.5
Body	IN	inlet - 1/4" GAS
	OUT	outlet - 1/4" GAS
Cover	A	ø22 female cover for left multiple pump element

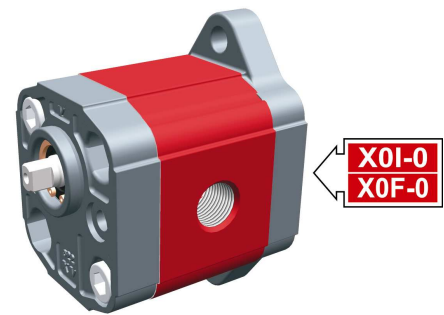

XT012

Technical data table						
TYPE	Displacement cm3/rev	Max. Pressure		CODE		
		P1 bar	P3 bar	Left rotation		Right rotation
XOT/0.17	0,16	220	260	X 0 T 01 11 B B B A	X 0 T 01 12 B B B A	X 0 T 01 12 B B B A
XOT/0.25	0,24	220	260	X 0 T 02 11 B B B A	X 0 T 02 12 B B B A	X 0 T 02 12 B B B A
XOT/0.45	0,45	220	280	X 0 T 04 11 B B B A	X 0 T 04 12 B B B A	X 0 T 04 12 B B B A
XOT/0.57	0,56	220	280	X 0 T 05 11 B B B A	X 0 T 05 12 B B B A	X 0 T 05 12 B B B A
XOT/0.76	0,75	220	280	X 0 T 06 11 B B B A	X 0 T 06 12 B B B A	X 0 T 06 12 B B B A
XOT/0.98	0,92	220	280	X 0 T 07 11 B B B A	X 0 T 07 12 B B B A	X 0 T 07 12 B B B A
XOT/1.27	1,26	220	280	X 0 T 09 11 B B B A	X 0 T 09 12 B B B A	X 0 T 09 12 B B B A
XOT/1.52	1,48	220	280	X 0 T 11 11 B B B A	X 0 T 11 12 B B B A	X 0 T 11 12 B B B A
XOT/2.30	2,28	190	210	X 0 T 13 11 B B B A	X 0 T 13 12 B B B A	X 0 T 13 12 B B B A

P1) Max. working pressure - P3) Max. peak pressure

For heavy-duty applications, it is recommended to check the admissible torque of the shaft

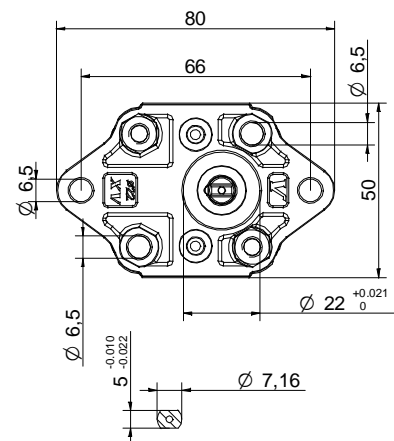

Dimensions table					
TYPE	Weight	A	B	D	D
	kg	mm	mm	IN	OUT
XOT/0.17	0,400	52,3	26,2	1/4" BSPP	1/4" BSPP
XOT/0.25	0,410	52,9	26,5	1/4" BSPP	1/4" BSPP
XOT/0.45	0,420	54,5	27,3	1/4" BSPP	1/4" BSPP
XOT/0.57	0,430	55,5	27,8	1/4" BSPP	1/4" BSPP
XOT/0.76	0,440	57,0	28,5	1/4" BSPP	1/4" BSPP
XOT/0.98	0,460	58,5	29,3	1/4" BSPP	1/4" BSPP
XOT/1.27	0,480	61,0	30,5	1/4" BSPP	1/4" BSPP
XOT/1.52	0,500	63,0	31,5	1/4" BSPP	1/4" BSPP
XOT/2.30	0,560	69,0	34,5	1/4" BSPP	1/4" BSPP

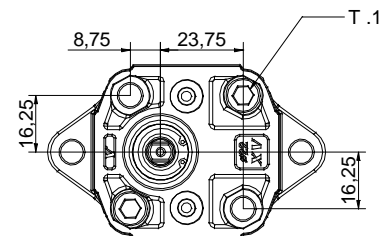
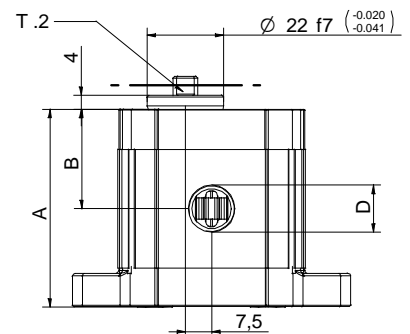

T.1 = 11.7÷13.7 [Nm] - screw tightening torque M6

T.2 = 9.2 [Nm] - admissible shaft torque (N.B. When choosing a shaft, always check the admissible torque).

10/04/08 XOT061288BA.dft

Table of variations

XOT

ø22 "BH" Body-Shaped FLANGE

ø22 "BH" Body-Shaped FLANGE				Shaft				Cover		
Left rotation		Right rotation						Left rotation	Right rotation	
	11		12	CIP01 - Parallel T.2 = 2.1 [Nm]	A	CFP01 - Milled shank T.2 = 9.2 [Nm]	B			A
	13		14	CF005 - Milled shank T.2 = 8.4 [Nm]	F	CO001 - Tapered T.2 = 21.9 [Nm]	E			D
	15		16							
	17		18							

Displacement	
TYPE	CODE
XOT/0.17	01
XOT/0.25	02
XOT/0.45	04
XOT/0.57	05
XOT/0.76	06
XOT/0.98	07
XOT/1.27	09
XOT/1.52	11
XOT/2.30	13

Standard bodies			
Displacement cm3/rev	Standard threads		
	0.17	B - B	Z - B
0.25	B - B	Z - B	Z - Z
0.45	B - B	Z - B	Z - Z
0.57	B - B	Z - B	Z - Z
0.76	B - B	Z - B	Z - Z
0.98	B - B	Z - B	Z - Z
1.27	B - B	Z - B	Z - Z
1.52	B - B	Z - B	Z - Z
2.30	B - B	Z - B	Z - Z

Table showing standard flange and thread combinations available in stock

Body (threads/flanges)													
	A		B		C		D		E		F		G
	H		I	Closed Body		Z							

entrainment pump - series XV

XOT

"HY" DRIVING PUMP
 ø22 BODY-SHAPED FLANGE - MILLED SHANK

X 0 T 06 22 B B B A

Series	X	series XV
Group	0	group 0
Category	T	entrainment pump
Displacement	06	0.76
Flange	22	Ø22 HY right rotation
Shaft	B	CFP01 - Milled shank ø7 - thk.5
Body	IN	inlet - 1/4" GAS
	OUT	outlet - 1/4" GAS
Cover	A	ø22 female cover for left multiple pump element

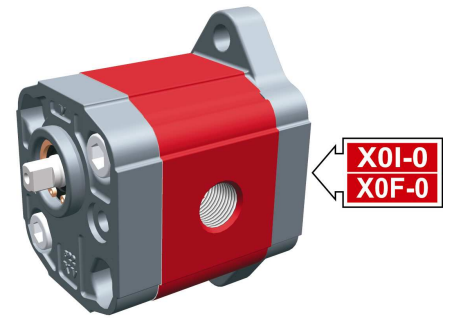

XT017

Technical data table

TYPE	Displacement cm3/rev	Max. Pressure		CODE	
		P1 bar	P3 bar	Left rotation	Right rotation
XOT/0.17	0,16	220	260	X 0 T 01 21 B B B A	X 0 T 01 22 B B B A
XOT/0.25	0,24	220	260	X 0 T 02 21 B B B A	X 0 T 02 22 B B B A
XOT/0.45	0,45	220	280	X 0 T 04 21 B B B A	X 0 T 04 22 B B B A
XOT/0.57	0,56	220	280	X 0 T 05 21 B B B A	X 0 T 05 22 B B B A
XOT/0.76	0,75	220	280	X 0 T 06 21 B B B A	X 0 T 06 22 B B B A
XOT/0.98	0,92	220	280	X 0 T 07 21 B B B A	X 0 T 07 22 B B B A
XOT/1.27	1,26	220	280	X 0 T 09 21 B B B A	X 0 T 09 22 B B B A
XOT/1.52	1,48	220	280	X 0 T 11 21 B B B A	X 0 T 11 22 B B B A
XOT/2.30	2,28	190	210	X 0 T 13 21 B B B A	X 0 T 13 22 B B B A

P1) Max. working pressure - P3) Max. peak pressure

For heavy-duty applications, it is recommended to check the admissible torque of the shaft

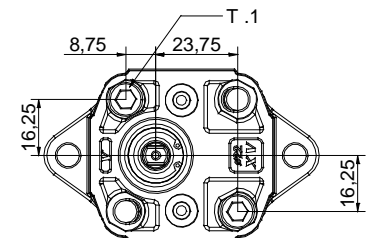
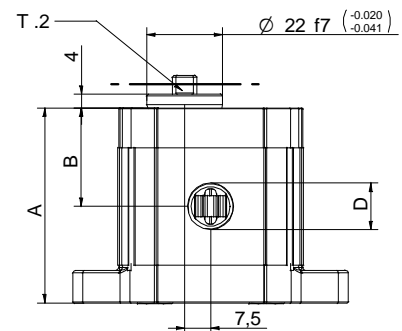
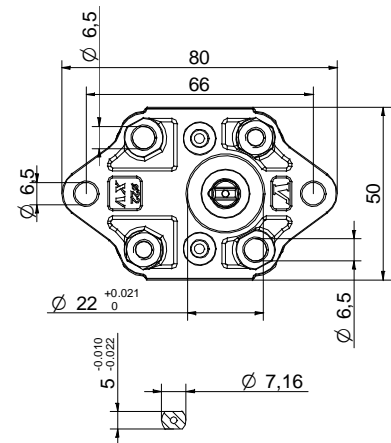

10/04/08 XOT06.2288BA.dft

Dimensions table

TYPE	Weight kg	A		D	
		mm	mm	IN	OUT
XOT/0.17	0,400	52,3	26,2	1/4" BSPP	1/4" BSPP
XOT/0.25	0,410	52,9	26,5	1/4" BSPP	1/4" BSPP
XOT/0.45	0,420	54,5	27,3	1/4" BSPP	1/4" BSPP
XOT/0.57	0,430	55,5	27,8	1/4" BSPP	1/4" BSPP
XOT/0.76	0,440	57,0	28,5	1/4" BSPP	1/4" BSPP
XOT/0.98	0,460	58,5	29,3	1/4" BSPP	1/4" BSPP
XOT/1.27	0,480	61,0	30,5	1/4" BSPP	1/4" BSPP
XOT/1.52	0,500	63,0	31,5	1/4" BSPP	1/4" BSPP
XOT/2.30	0,560	69,0	34,5	1/4" BSPP	1/4" BSPP

T.1 = 11.7÷13.7 [Nm] - screw tightening torque M6

T.2 = 9.2 [Nm] - admissible shaft torque (N.B. When choosing a shaft, always check the admissible torque).

Table of variations

XOT

ø22 "HY" Body-Shaped FLANGE

ø22 "HY" Body-Shaped FLANGE				Shaft				Cover		
Left rotation		Right rotation						Left rotation	Right rotation	
	21		22	CIP01 - Parallel T.2 = 2.1 [Nm]	A	CFP01 - Milled shank T.2 = 9.2 [Nm]	B			A
	23		24	CF005 - Milled shank T.2 = 8.4 [Nm]	F	CO001 - Tapered T.2 = 21.9 [Nm]	E			D
	25		26							
	27		28							

Displacement	
TYPE	CODE
XOT/0.17	01
XOT/0.25	02
XOT/0.45	04
XOT/0.57	05
XOT/0.76	06
XOT/0.98	07
XOT/1.27	09
XOT/1.52	11
XOT/2.30	13

Standard bodies			
Displacement cm3/rev	Standard threads		
	0.17	B - B	Z - B
0.25	B - B	Z - B	Z - Z
0.45	B - B	Z - B	Z - Z
0.57	B - B	Z - B	Z - Z
0.76	B - B	Z - B	Z - Z
0.98	B - B	Z - B	Z - Z
1.27	B - B	Z - B	Z - Z
1.52	B - B	Z - B	Z - Z
2.30	B - B	Z - B	Z - Z

Table showing standard flange and thread combinations available in stock

Body (threads/flanges)													
	A		B		C		D		E		F		G
	H		I	Closed Body		Z							

intermediate pump - series XV

XO1-0

STANDARD INTERMEDIATE PUMP
FEMALE Ø22 FLANGE

X 0 I 06 22 M B B A

Series	X	series XV
Group	0	group 0
Category	I	intermediate pump
Displacement	06	0.76
Flange	22	Ø22 female right rotation 0P+0P
Shaft	M	CFI01 - Intermediate - (Milled shank ø7 - thk.3)
Body	IN	inlet - 1/4" GAS
	OUT	outlet - 1/4" GAS
Cover	A	Ø22 female cover for left multiple pump element

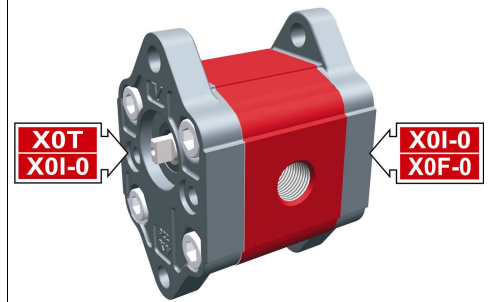

XI001

Technical data table

TYPE	Displacement cm3/rev	Max. Pressure		CODE	
		P1 bar	P3 bar	Left rotation	Right rotation
XO1-0/0.17	0,16	220	260	X 0 I 01 21 M B B A	X 0 I 01 22 M B B A
XO1-0/0.25	0,24	220	260	X 0 I 02 21 M B B A	X 0 I 02 22 M B B A
XO1-0/0.45	0,45	220	280	X 0 I 04 21 M B B A	X 0 I 04 22 M B B A
XO1-0/0.57	0,56	220	280	X 0 I 05 21 M B B A	X 0 I 05 22 M B B A
XO1-0/0.76	0,75	220	280	X 0 I 06 21 M B B A	X 0 I 06 22 M B B A
XO1-0/0.98	0,92	220	280	X 0 I 07 21 M B B A	X 0 I 07 22 M B B A
XO1-0/1.27	1,26	220	280	X 0 I 09 21 M B B A	X 0 I 09 22 M B B A
XO1-0/1.52	1,48	220	280	X 0 I 11 21 M B B A	X 0 I 11 22 M B B A
XO1-0/2.30	2,28	190	210	X 0 I 13 21 M B B A	X 0 I 13 22 M B B A

P1) Max. working pressure - P3) Max. peak pressure

For heavy-duty applications, it is recommended to check the admissible torque of the shaft

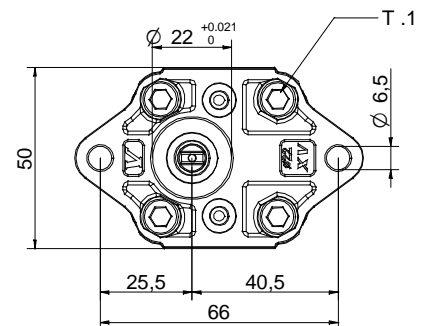
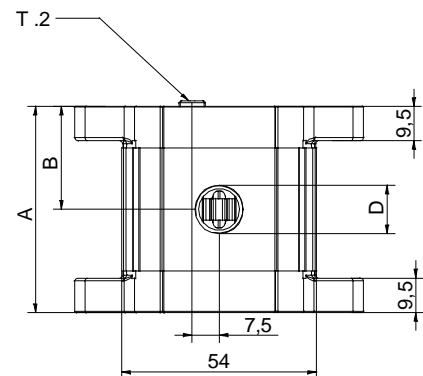
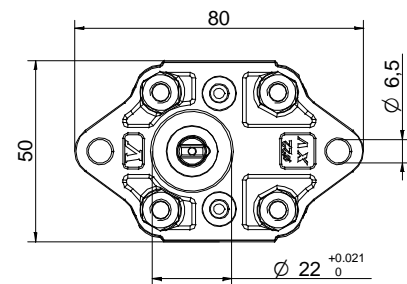

31/03/08 X010622MBBAdff

Dimensions table

TYPE	Weight kg	A	B	D	
		mm	mm	IN	OUT
XO1-0/0.17	0,400	52,3	26,2	1/4" BSPP	1/4" BSPP
XO1-0/0.25	0,410	52,9	26,5	1/4" BSPP	1/4" BSPP
XO1-0/0.45	0,420	54,5	27,3	1/4" BSPP	1/4" BSPP
XO1-0/0.57	0,430	55,5	27,8	1/4" BSPP	1/4" BSPP
XO1-0/0.76	0,440	57,0	28,5	1/4" BSPP	1/4" BSPP
XO1-0/0.98	0,460	58,5	29,3	1/4" BSPP	1/4" BSPP
XO1-0/1.27	0,480	61,0	30,5	1/4" BSPP	1/4" BSPP
XO1-0/1.52	0,500	63,0	31,5	1/4" BSPP	1/4" BSPP
XO1-0/2.30	0,560	69,0	34,5	1/4" BSPP	1/4" BSPP







T.1 = 11.7÷13.7 [Nm] - screw tightening torque M6

T.2 = 3.7 [Nm] - admissible shaft torque (N.B. When choosing a shaft, always check the admissible torque).

Table of variations

XOI-O

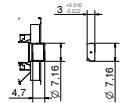
Standard female $\varnothing 22$ FLANGE

Standard female $\varnothing 22$ FLANGE				Shaft		Cover		
Left rotation		Right rotation				Left rotation	Right rotation	
	21		22	CFI01 - Milled shank - T.2 = 3.7 [Nm]				A
								D
				M				

Displacement	
TYPE	CODE
XOI-0/0.17	01
XOI-0/0.25	02
XOI-0/0.45	04
XOI-0/0.57	05
XOI-0/0.76	06
XOI-0/0.98	07
XOI-0/1.27	09
XOI-0/1.52	11
XOI-0/2.30	13

Standard bodies	
Displacement cm ³ /rev standard thread	
0.17	B - B
0.25	B - B
0.45	B - B
0.57	B - B
0.76	B - B
0.98	B - B
1.27	B - B
1.52	B - B
2.30	B - B

Table showing standard flange and thread combinations available in stock

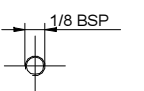
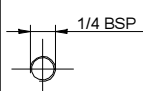
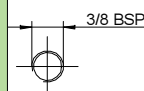
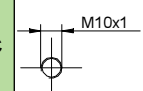
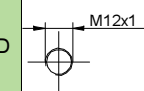
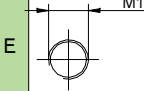
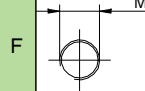
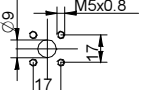
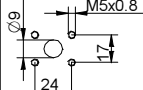
Body (threads/flanges)													
	A		B		C		D		E		F		G
	H		I	Closed Body		Z							

intermediate pump - series XV

XO1-0

SHAPED INTERMEDIATE PUMP
SHAPED FEMALE Ø22 FLANGE

X 0 I 06 24 M B B D

Series	X	series XV
Group	0	group 0
Category	I	intermediate pump
Displacement	06	0.76
Flange	24	Ø22 body-shaped female right rotation 0P+0P
Shaft	M	CFI01 - Intermediate - (Milled shank ø7 - thk.3)
Body	IN	inlet - 1/4" GAS
	OUT	outlet - 1/4" GAS
Cover	D	Ø22 female cover for left multiple pump element

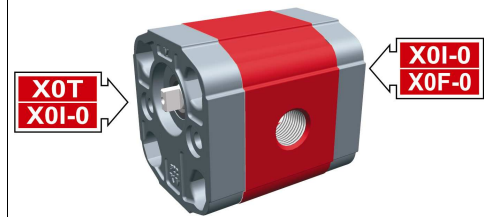

XI002

Technical data table

TYPE	Displacement cm3/rev	Max. Pressure		CODE	
		P1 bar	P3 bar	Left rotation	Right rotation
XO1-0/0.17	0,16	220	260	X 0 I 01 23 M B B A	X 0 I 01 24 M B B A
XO1-0/0.25	0,24	220	260	X 0 I 02 23 M B B A	X 0 I 02 24 M B B A
XO1-0/0.45	0,45	220	280	X 0 I 04 23 M B B A	X 0 I 04 24 M B B A
XO1-0/0.57	0,56	220	280	X 0 I 05 23 M B B A	X 0 I 05 24 M B B A
XO1-0/0.76	0,75	220	280	X 0 I 06 23 M B B A	X 0 I 06 24 M B B A
XO1-0/0.98	0,92	220	280	X 0 I 07 23 M B B A	X 0 I 07 24 M B B A
XO1-0/1.27	1,26	220	280	X 0 I 09 23 M B B A	X 0 I 09 24 M B B A
XO1-0/1.52	1,48	220	280	X 0 I 11 23 M B B A	X 0 I 11 24 M B B A
XO1-0/2.30	2,28	190	210	X 0 I 13 23 M B B A	X 0 I 13 24 M B B A

P1) Max. working pressure - P3) Max. peak pressure

For heavy-duty applications, it is recommended to check the admissible torque of the shaft

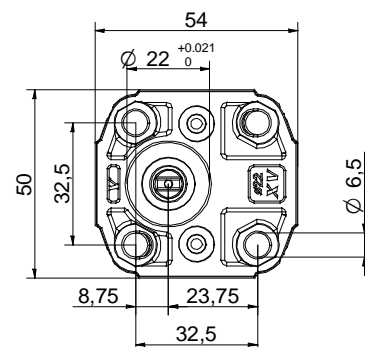
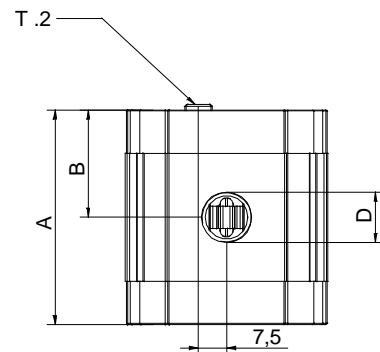
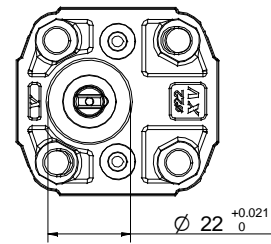

01/04/08 X010624M6B0.dft

Dimensions table

TYPE	Weight kg	A	B	D	D
		mm	mm	IN	OUT
XO1-0/0.17	0,400	52,3	26,2	1/4" BSPP	1/4" BSPP
XO1-0/0.25	0,410	52,9	26,5	1/4" BSPP	1/4" BSPP
XO1-0/0.45	0,420	54,5	27,3	1/4" BSPP	1/4" BSPP
XO1-0/0.57	0,430	55,5	27,8	1/4" BSPP	1/4" BSPP
XO1-0/0.76	0,440	57,0	28,5	1/4" BSPP	1/4" BSPP
XO1-0/0.98	0,460	58,5	29,3	1/4" BSPP	1/4" BSPP
XO1-0/1.27	0,480	61,0	30,5	1/4" BSPP	1/4" BSPP
XO1-0/1.52	0,500	63,0	31,5	1/4" BSPP	1/4" BSPP
XO1-0/2.30	0,560	69,0	34,5	1/4" BSPP	1/4" BSPP

T.2 = 3.7 [Nm] - admissible shaft torque (N.B. When choosing a shaft, always check the admissible torque).

Table of variations

XOI-O

Shaped female $\varnothing 22$ FLANGE

Shaped female $\varnothing 22$ FLANGE				Shaft		Cover		
Left rotation		Right rotation				Left rotation	Right rotation	
	23		24	CFI01 - Milled shank T.2 = 3.7 [Nm]	M			A
								D

Displacement	
TYPE	CODE
XOI-0/0.17	01
XOI-0/0.25	02
XOI-0/0.45	04
XOI-0/0.57	05
XOI-0/0.76	06
XOI-0/0.98	07
XOI-0/1.27	09
XOI-0/1.52	11
XOI-0/2.30	13

Standard bodies	
Displacement cm ³ /rev standard thread	
0.17	B - B
0.25	B - B
0.45	B - B
0.57	B - B
0.76	B - B
0.98	B - B
1.27	B - B
1.52	B - B
2.30	B - B

Table showing standard flange and thread combinations available in stock

Body (threads/flanges)													
	A		B		C		D		E		F		G
	H		I	Closed Body		Z							

intermediate pump - series XV

XO1-1

INTERMEDIATE PUMP TO BE COUPLED WITH XV1
FEMALE Ø25,4 FLANGE

X 0 I 06 32 A B B A

Series	X	series XV
Group	0	group 0
Category	I	intermediate pump
Displacement	06	0.76
Flange	32	Ø25.4 female right rotation 1P+0P
Shaft	A	CIP01 - Intermediate for 1+0 - 2+0 (Parallel ø7 - M7x1 - key thk. 2)
Body	IN	inlet - 1/4" GAS
	OUT	outlet - 1/4" GAS
Cover	A	ø22 female cover for left multiple pump element

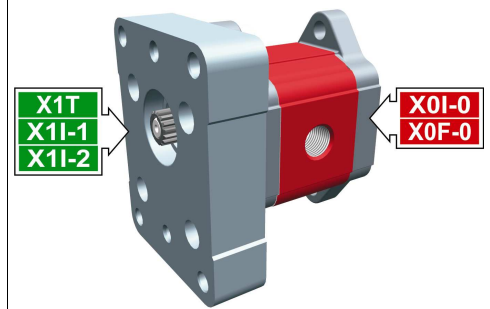

XI003

Technical data table

TYPE	Displacement cm3/rev	Max. Pressure		CODE	
		P1 bar	P3 bar	Left rotation	Right rotation
XO1-1/0.17	0,16	220	260	X 0 I 01 31 A B B A	X 0 I 01 32 A B B A
XO1-1/0.25	0,24	220	260	X 0 I 02 31 A B B A	X 0 I 02 32 A B B A
XO1-1/0.45	0,45	220	280	X 0 I 04 31 A B B A	X 0 I 04 32 A B B A
XO1-1/0.57	0,56	220	280	X 0 I 05 31 A B B A	X 0 I 05 32 A B B A
XO1-1/0.76	0,75	220	280	X 0 I 06 31 A B B A	X 0 I 06 32 A B B A
XO1-1/0.98	0,92	220	280	X 0 I 07 31 A B B A	X 0 I 07 32 A B B A
XO1-1/1.27	1,26	220	280	X 0 I 09 31 A B B A	X 0 I 09 32 A B B A
XO1-1/1.52	1,48	220	280	X 0 I 11 31 A B B A	X 0 I 11 32 A B B A
XO1-1/2.30	2,28	190	210	X 0 I 13 31 A B B A	X 0 I 13 32 A B B A

P1) Max. working pressure - P3) Max. peak pressure

For heavy-duty applications, it is recommended to check the admissible torque of the shaft

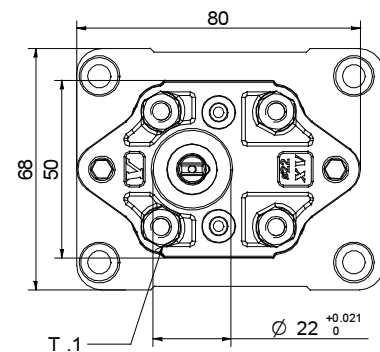

Dimensions table

TYPE	Weight kg	A	B	D	D
		mm	mm	IN	OUT
XO1-1/0.17	0,400	72,3	46,2	1/4" BSPP	1/4" BSPP
XO1-1/0.25	0,410	72,9	46,5	1/4" BSPP	1/4" BSPP
XO1-1/0.45	0,420	74,5	47,3	1/4" BSPP	1/4" BSPP
XO1-1/0.57	0,430	75,5	47,8	1/4" BSPP	1/4" BSPP
XO1-1/0.76	0,440	77,0	48,5	1/4" BSPP	1/4" BSPP
XO1-1/0.98	0,460	78,5	49,3	1/4" BSPP	1/4" BSPP
XO1-1/1.27	0,480	81,0	50,5	1/4" BSPP	1/4" BSPP
XO1-1/1.52	0,500	83,0	51,5	1/4" BSPP	1/4" BSPP
XO1-1/2.30	0,560	89,0	54,5	1/4" BSPP	1/4" BSPP

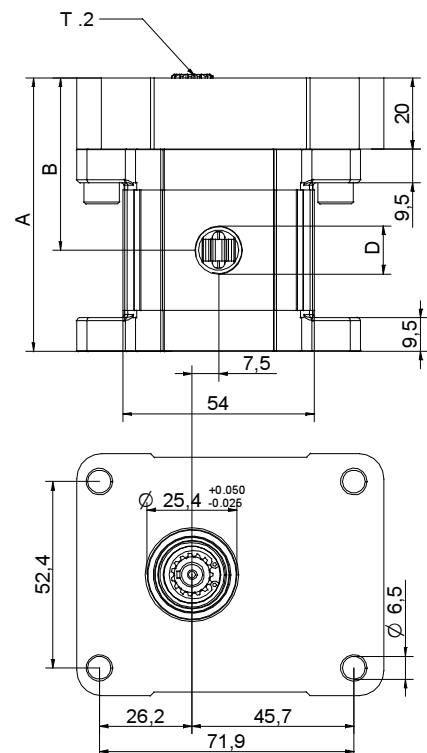

0104/08 X010632ABBA.dff

T.1 = 11.7÷13.7 [Nm] - screw tightening torque M6

T.2 = 2.1 [Nm] - admissible shaft torque (N.B. When choosing a shaft, always check the admissible torque).

Table of variations

XOI-1

Female $\varnothing 25,4$ FLANGE

Female $\varnothing 25,4$ FLANGE		Shaft		Cover		
Left rotation	Right rotation			Left rotation	Right rotation	
		CIP01 - Parallel T.2 = 2.1 [Nm] 				A
						D

Displacement	
TYPE	CODE
XOI-1/0.17	01
XOI-1/0.25	02
XOI-1/0.45	04
XOI-1/0.57	05
XOI-1/0.76	06
XOI-1/0.98	07
XOI-1/1.27	09
XOI-1/1.52	11
XOI-1/2.30	13

Standard bodies	
Displacement cm ³ /rev standard thread	
0.17	B - B
0.25	B - B
0.45	B - B
0.57	B - B
0.76	B - B
0.98	B - B
1.27	B - B
1.52	B - B
2.30	B - B

Table showing standard flange and thread combinations available in stock

Body (threads/flanges)						
		Closed Body		Z		

intermediate pump - series XV

XO1-2

INTERMEDIATE PUMP TO BE COUPLED WITH XV2
FEMALE Ø36,5 FLANGE

X 0 I 06 42 A B B A

Series	X	series XV
Group	0	group 0
Category	I	intermediate pump
Displacement	06	0.76
Flange	42	Ø36.5 female right rotation 2P+0P, 3P+0P
Shaft	A	CIP01 - Intermediate for 1+0 - 2+0 (Parallel ø7 - M7x1 - key thk. 2)
Body	IN	inlet - 1/4" GAS
	OUT	outlet - 1/4" GAS
Cover	A	ø22 female cover for left multiple pump element

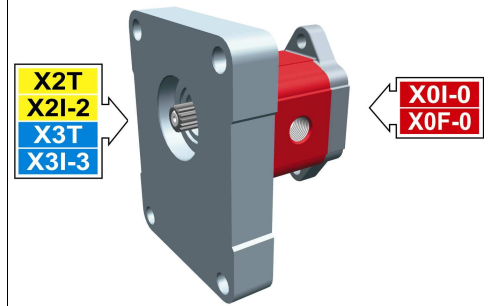

XI004

Technical data table

TYPE	Displacement cm3/rev	Max. Pressure		CODE	
		P1 bar	P3 bar	Left rotation	Right rotation
XO1-2/0.17	0,16	220	260	X 0 I 01 41 A B B A	X 0 I 01 42 A B B A
XO1-2/0.25	0,24	220	260	X 0 I 02 41 A B B A	X 0 I 02 42 A B B A
XO1-2/0.45	0,45	220	280	X 0 I 04 41 A B B A	X 0 I 04 42 A B B A
XO1-2/0.57	0,56	220	280	X 0 I 05 41 A B B A	X 0 I 05 42 A B B A
XO1-2/0.76	0,75	220	280	X 0 I 06 41 A B B A	X 0 I 06 42 A B B A
XO1-2/0.98	0,92	220	280	X 0 I 07 41 A B B A	X 0 I 07 42 A B B A
XO1-2/1.27	1,26	220	280	X 0 I 09 41 A B B A	X 0 I 09 42 A B B A
XO1-2/1.52	1,48	220	280	X 0 I 11 41 A B B A	X 0 I 11 42 A B B A
XO1-2/2.30	2,28	190	210	X 0 I 13 41 A B B A	X 0 I 13 42 A B B A

P1) Max. working pressure - P3) Max. peak pressure

For heavy-duty applications, it is recommended to check the admissible torque of the shaft

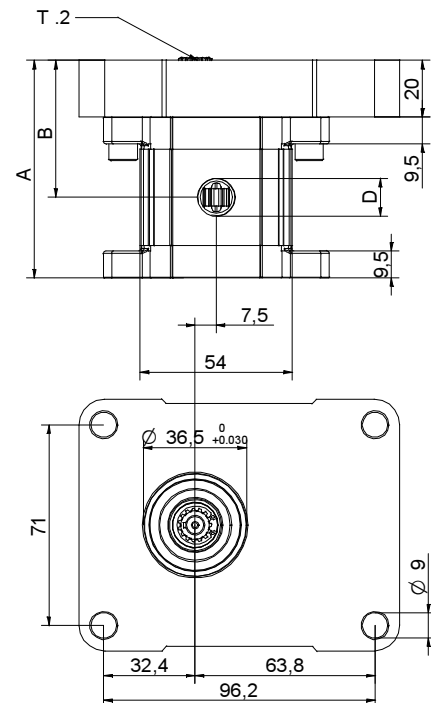
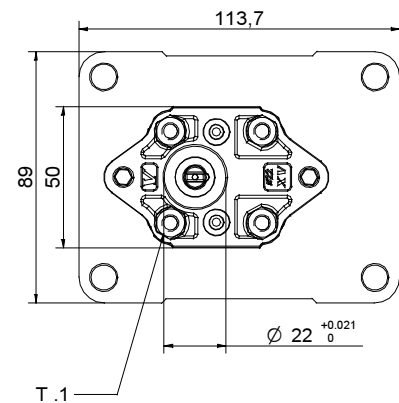

T.1 = 11.7÷13.7 [Nm] - screw tightening torque M6

T.2 = 2.1 [Nm] - admissible shaft torque (N.B. When choosing a shaft, always check the admissible torque).

Table of variations

XO1-2

Female $\varnothing 36.5$ FLANGE

Female $\varnothing 36.5$ FLANGE		Shaft		Cover		
Left rotation	Right rotation			Left rotation	Right rotation	
		CIP01 - Parallel $T.2 = 2.1$ [Nm] $m=0.75$ $Z=15$ 				A
41	42	A				D

Displacement	
TYPE	CODE
XO1-2/0.17	01
XO1-2/0.25	02
XO1-2/0.45	04
XO1-2/0.57	05
XO1-2/0.76	06
XO1-2/0.98	07
XO1-2/1.27	09
XO1-2/1.52	11
XO1-2/2.30	13

Standard bodies	
Displacement cm3/rev standard thread	
0.17	B - B
0.25	B - B
0.45	B - B
0.57	B - B
0.76	B - B
0.98	B - B
1.27	B - B
1.52	B - B
2.30	B - B

Table showing standard flange and thread combinations available in stock

Body (threads/flanges)													
	A		B		C		D		E		F		G
	H		I	Closed Body		Z							

final pump - series XV

XOF-0

STANDARD FINAL PUMP
FEMALE Ø22 FLANGE

X 0 F 06 22 N B B A

Series	X	series XV
Group	0	group 0
Category	F	final pump
Displacement	06	0.76
Flange	22	Ø22 female right rotation 0P+0P
Shaft	N	CFF01 - Final - Milled shank ø7.16 - thk.3
Body	IN	inlet - 1/4" GAS
	OUT	outlet - 1/4" GAS
Cover	A	standard

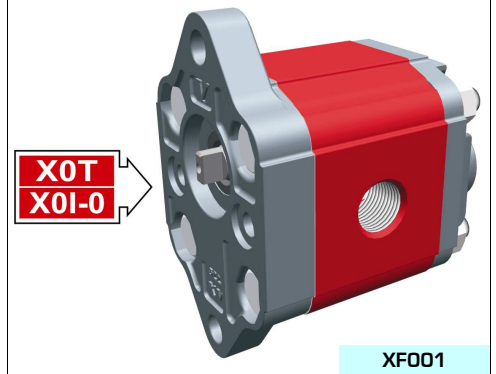

Technical data table						
TYPE	Displacement cm3/rev	Max. Pressure		CODE		
		P1 bar	P3 bar	Left rotation		Right rotation
XOF-0/0.17	0,16	220	260	X 0 F 01 21 N B B A	X 0 F 01 22 N B B A	
XOF-0/0.25	0,24	220	260	X 0 F 02 21 N B B A	X 0 F 02 22 N B B A	
XOF-0/0.45	0,45	220	280	X 0 F 04 21 N B B A	X 0 F 04 22 N B B A	
XOF-0/0.57	0,56	220	280	X 0 F 05 21 N B B A	X 0 F 05 22 N B B A	
XOF-0/0.76	0,75	220	280	X 0 F 06 21 N B B A	X 0 F 06 22 N B B A	
XOF-0/0.98	0,92	220	280	X 0 F 07 21 N B B A	X 0 F 07 22 N B B A	
XOF-0/1.27	1,26	220	280	X 0 F 09 21 N B B A	X 0 F 09 22 N B B A	
XOF-0/1.52	1,48	220	280	X 0 F 11 21 N B B A	X 0 F 11 22 N B B A	
XOF-0/2.30	2,28	190	210	X 0 F 13 21 N B B A	X 0 F 13 22 N B B A	

P1) Max. working pressure - P3) Max. peak pressure

For heavy-duty applications, it is recommended to check the admissible torque of the shaft

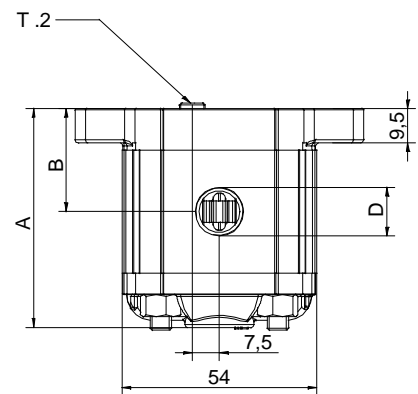
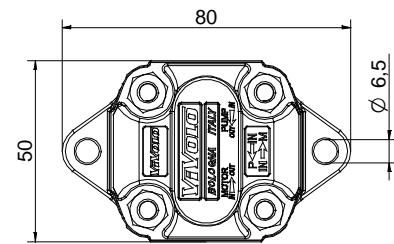

Dimensions table					
TYPE	Weight	A	B	D	D
	kg	mm	mm	IN	OUT
XOF-0/0.17	0,400	55,8	26,2	1/4" BSPP	1/4" BSPP
XOF-0/0.25	0,410	56,4	26,5	1/4" BSPP	1/4" BSPP
XOF-0/0.45	0,420	58,0	27,3	1/4" BSPP	1/4" BSPP
XOF-0/0.57	0,430	59,0	27,8	1/4" BSPP	1/4" BSPP
XOF-0/0.76	0,440	60,5	28,5	1/4" BSPP	1/4" BSPP
XOF-0/0.98	0,460	62,0	29,3	1/4" BSPP	1/4" BSPP
XOF-0/1.27	0,480	64,5	30,5	1/4" BSPP	1/4" BSPP
XOF-0/1.52	0,500	66,5	31,5	1/4" BSPP	1/4" BSPP
XOF-0/2.30	0,560	72,5	34,5	1/4" BSPP	1/4" BSPP

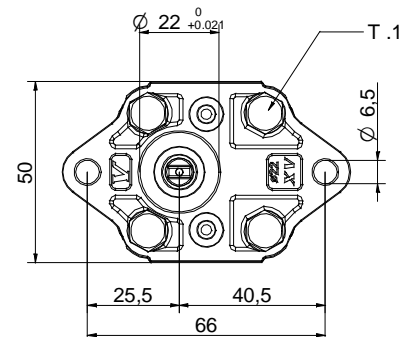

01/04/08 XOF0622NBA.dft

T.1 = 11.7÷13.7 [Nm] - screw tightening torque M6

T.2 = 3.7 [Nm] - admissible shaft torque (N.B. When choosing a shaft, always check the admissible torque).

final pump - series XV

XOF-0

SHAPED FINAL PUMP
SHAPED FEMALE Ø22 FLANGE

X 0 F 06 24 N B B A

Series	X	series XV
Group	0	group 0
Category	F	final pump
Displacement	06	0.76
Flange	24	Ø22 body-shaped female right rotation 0P+0P
Shaft	N	CFF01 - Final - Milled shank ø7.16 - thk.3
Body	IN	inlet - 1/4" GAS
	OUT	outlet - 1/4" GAS
Cover	A	standard

XOT
XOI-0



XF002

Technical data table

TYPE	Displacement cm3/rev	Max. Pressure		CODE	
		P1 bar	P3 bar	Left rotation	Right rotation
XOF-0/0.17	0,16	220	260	X 0 F 01 23 N B B A	X 0 F 01 24 N B B A
XOF-0/0.25	0,24	220	260	X 0 F 02 23 N B B A	X 0 F 02 24 N B B A
XOF-0/0.45	0,45	220	280	X 0 F 04 23 N B B A	X 0 F 04 24 N B B A
XOF-0/0.57	0,56	220	280	X 0 F 05 23 N B B A	X 0 F 05 24 N B B A
XOF-0/0.76	0,75	220	280	X 0 F 06 23 N B B A	X 0 F 06 24 N B B A
XOF-0/0.98	0,92	220	280	X 0 F 07 23 N B B A	X 0 F 07 24 N B B A
XOF-0/1.27	1,26	220	280	X 0 F 09 23 N B B A	X 0 F 09 24 N B B A
XOF-0/1.52	1,48	220	280	X 0 F 11 23 N B B A	X 0 F 11 24 N B B A
XOF-0/2.30	2,28	190	210	X 0 F 13 23 N B B A	X 0 F 13 24 N B B A

P1) Max. working pressure - P3) Max. peak pressure

For heavy-duty applications, it is recommended to check the admissible torque of the shaft

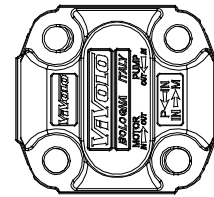

T.2

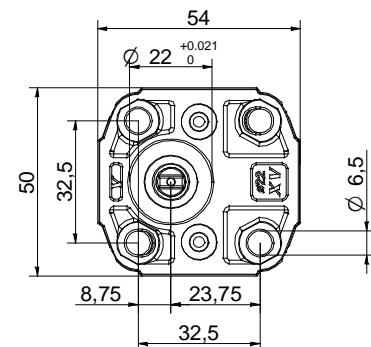
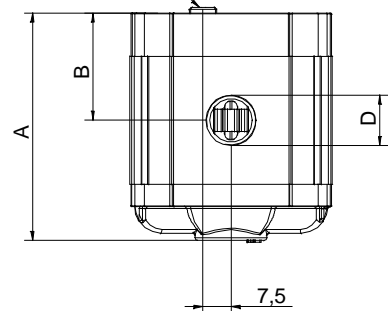

11/04/08 XOF0624NBA.dft

Dimensions table





TYPE	Weight kg	A	B	D	D
		mm	mm	IN	OUT
XOF-0/0.17	0,400	55,8	26,2	1/4" BSPP	1/4" BSPP
XOF-0/0.25	0,410	56,4	26,5	1/4" BSPP	1/4" BSPP
XOF-0/0.45	0,420	58,0	27,3	1/4" BSPP	1/4" BSPP
XOF-0/0.57	0,430	59,0	27,8	1/4" BSPP	1/4" BSPP
XOF-0/0.76	0,440	60,5	28,5	1/4" BSPP	1/4" BSPP
XOF-0/0.98	0,460	62,0	29,3	1/4" BSPP	1/4" BSPP
XOF-0/1.27	0,480	64,5	30,5	1/4" BSPP	1/4" BSPP
XOF-0/1.52	0,500	66,5	31,5	1/4" BSPP	1/4" BSPP
XOF-0/2.30	0,560	72,5	34,5	1/4" BSPP	1/4" BSPP

T.2 = 3.7 [Nm] - admissible shaft torque (N.B. When choosing a shaft, always check the admissible torque).

Table of variations

XOF-O

Shaped female $\varnothing 22$ FLANGE

Shaped female $\varnothing 22$ FLANGE		Shaft		Cover		
Left rotation	Right rotation			Left rotation	Right rotation	
	23		24	CFF01 - Milled shank T.2 = 3.7 [Nm]		N
						A

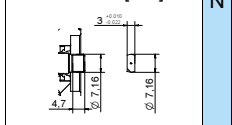

Displacement	
TYPE	CODE
XOF-0/0.17	01
XOF-0/0.25	02
XOF-0/0.45	04
XOF-0/0.57	05
XOF-0/0.76	06
XOF-0/0.98	07
XOF-0/1.27	09
XOF-0/1.52	11
XOF-0/2.30	13

Displacement cm ³ /rev	Standard bodies		
	Standard threads		
0.17	B - B	Z - B	Z - Z
0.25	B - B	Z - B	Z - Z
0.45	B - B	Z - B	Z - Z
0.57	B - B	Z - B	Z - Z
0.76	B - B	Z - B	Z - Z
0.98	B - B	Z - B	Z - Z
1.27	B - B	Z - B	Z - Z
1.52	B - B	Z - B	Z - Z
2.30	B - B	Z - B	Z - Z

Table showing standard flange and thread combinations available in stock

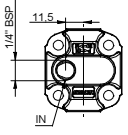
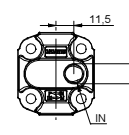
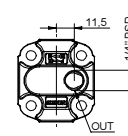
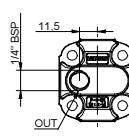
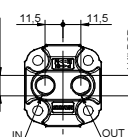
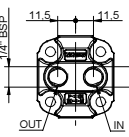
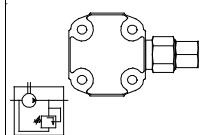
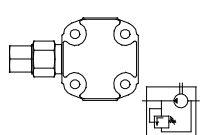
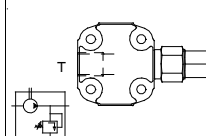
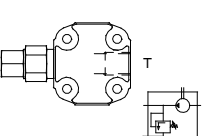
		B
		C
		D
 		N
 		O

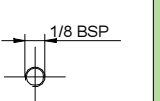
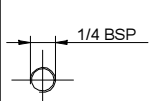
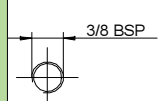
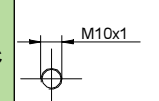
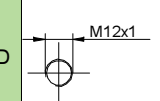
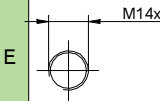
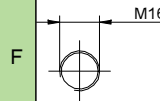
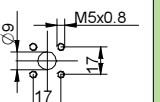
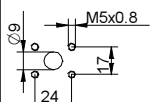
Body (threads/flanges)													
	A		B		C		D		E		F		G
	H		I	Closed Body		Z							

final pump - series XV

XOF-1

FINAL PUMP TO BE COUPLED WITH XV1
FEMALE Ø25,4 FLANGE

X 0 F 06 32 G B B A

Series	X	series XV
Group	0	group 0
Category	F	final pump
Displacement	06	0.76
Flange	32	Ø25.4 female right rotation 1P+0P
Shaft	G	CI001 - Final for 1+0, 2+0
Body	IN	inlet - 1/4" GAS
	OUT	outlet - 1/4" GAS
Cover	A	standard

X1T
X11-1
X11-2

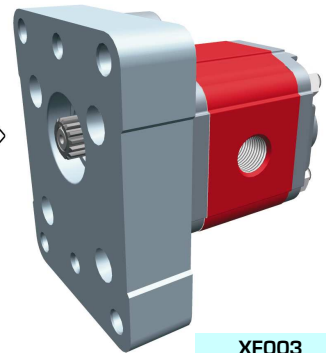

XF003

Technical data table

TYPE	Displacement cm3/rev	Max. Pressure		CODE	
		P1 bar	P3 bar	Left rotation	Right rotation
XOF-1/0.17	0,16	220	260	X 0 F 01 31 G B B A	X 0 F 01 32 G B B A
XOF-1/0.25	0,24	220	260	X 0 F 02 31 G B B A	X 0 F 02 32 G B B A
XOF-1/0.45	0,45	220	280	X 0 F 04 31 G B B A	X 0 F 04 32 G B B A
XOF-1/0.57	0,56	220	280	X 0 F 05 31 G B B A	X 0 F 05 32 G B B A
XOF-1/0.76	0,75	220	280	X 0 F 06 31 G B B A	X 0 F 06 32 G B B A
XOF-1/0.98	0,92	220	280	X 0 F 07 31 G B B A	X 0 F 07 32 G B B A
XOF-1/1.27	1,26	220	280	X 0 F 09 31 G B B A	X 0 F 09 32 G B B A
XOF-1/1.52	1,48	220	280	X 0 F 11 31 G B B A	X 0 F 11 32 G B B A
XOF-1/2.30	2,28	190	210	X 0 F 13 31 G B B A	X 0 F 13 32 G B B A

P1) Max. working pressure - P3) Max. peak pressure

For heavy-duty applications, it is recommended to check the admissible torque of the shaft

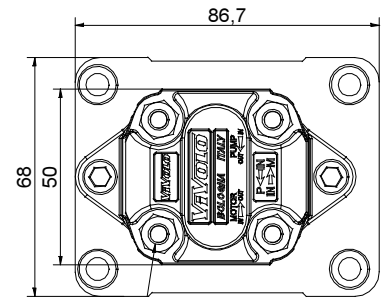

T.1

T.2

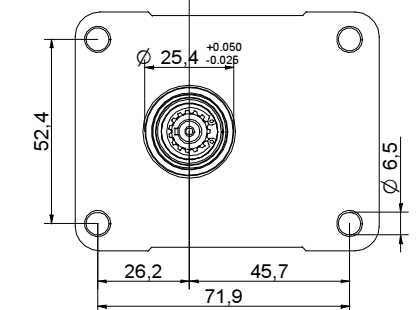
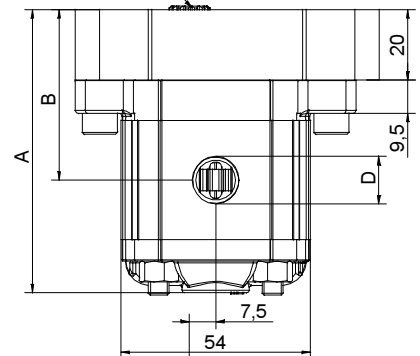

0104/08 XOF06:32GBBA.dft

T.1 = 11.7÷13.7 [Nm] - screw tightening torque M6

T.2 = 2.1 [Nm] - admissible shaft torque (N.B. When choosing a shaft, always check the admissible torque).

Dimensions table



TYPE	Weight kg	A	B	D	D
		mm	mm	IN	OUT
XOF-1/0.17	0,400	75,8	46,2	1/4" BSPP	1/4" BSPP
XOF-1/0.25	0,410	76,4	46,5	1/4" BSPP	1/4" BSPP
XOF-1/0.45	0,420	78,0	47,3	1/4" BSPP	1/4" BSPP
XOF-1/0.57	0,430	79,0	47,8	1/4" BSPP	1/4" BSPP
XOF-1/0.76	0,440	80,5	48,5	1/4" BSPP	1/4" BSPP
XOF-1/0.98	0,460	82,0	49,3	1/4" BSPP	1/4" BSPP
XOF-1/1.27	0,480	84,5	50,5	1/4" BSPP	1/4" BSPP
XOF-1/1.52	0,500	86,5	51,5	1/4" BSPP	1/4" BSPP
XOF-1/2.30	0,560	92,5	54,5	1/4" BSPP	1/4" BSPP

Table of variations

XOF-1

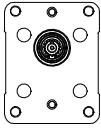
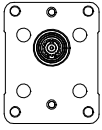
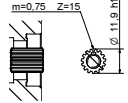
Female $\varnothing 25,4$ FLANGE

Female $\varnothing 25,4$ FLANGE		Shaft	
Left rotation	Right rotation		
		CI001 - Parallel T.2 = 2.1 [Nm] 	
31	32	G	

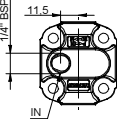
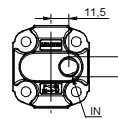
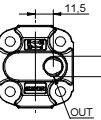
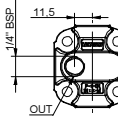
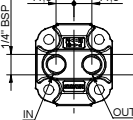
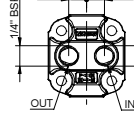
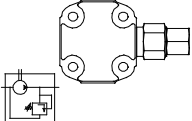
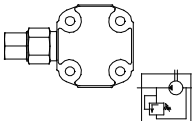
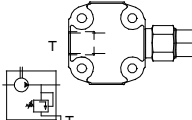
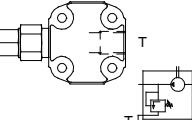
Cover		
Left rotation	Right rotation	
		A
		B
		C
		D
		N
Internal drainage		
		O
External drainage		

Displacement	
TYPE	CODE
XOF-1/0.17	01
XOF-1/0.25	02
XOF-1/0.45	04
XOF-1/0.57	05
XOF-1/0.76	06
XOF-1/0.98	07
XOF-1/1.27	09
XOF-1/1.52	11
XOF-1/2.30	13

Standard bodies				
Displacement cm ³ /rev	Standard threads			
	0.17	B - B	Z - B	Z - Z
0.25	B - B	Z - B	Z - Z	
0.45	B - B	Z - B	Z - Z	
0.57	B - B	Z - B	Z - Z	
0.76	B - B	Z - B	Z - Z	
0.98	B - B	Z - B	Z - Z	
1.27	B - B	Z - B	Z - Z	
1.52	B - B	Z - B	Z - Z	
2.30	B - B	Z - B	Z - Z	

Table showing standard flange and thread combinations available in stock

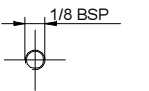
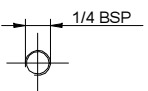
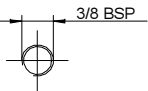
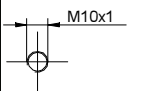
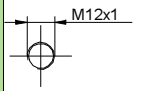
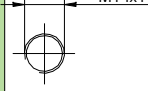
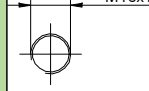
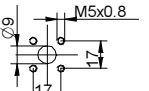
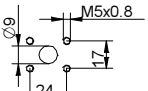
Body (threads/flanges)													
	A		B		C		D		E		F		G
	H		I	Closed Body		Z							

final pump - series XV

FINAL PUMP TO BE COUPLED WITH XV2
FEMALE Ø36,5 FLANGE

XOF-2

X 0 F 06 42 G B B A

Series	X	series XV
Group	0	group 0
Category	F	final pump
Displacement	06	0.76
Flange	42	Ø36.5 female right rotation 2P+0P, 3P+0P
Shaft	G	CI001 - Final for 1+0, 2+0
Body	IN	inlet - 1/4" GAS
	OUT	outlet - 1/4" GAS
Cover	A	standard

X2T
X2I-2
X3T
X3I-3

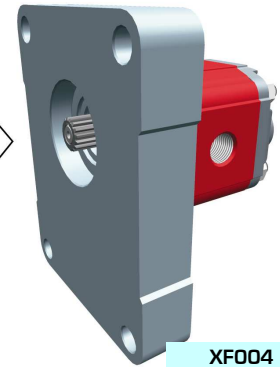

XF004

Technical data table

TYPE	Displacement cm3/rev	Max. Pressure		CODE			
		P1 bar	P3 bar	Left rotation		Right rotation	
XOF-2/0.17	0,16	220	260	X 0 F 01 41	G B B A	X 0 F 01 42	G B B A
XOF-2/0.25	0,24	220	260	X 0 F 02 41	G B B A	X 0 F 02 42	G B B A
XOF-2/0.45	0,45	220	280	X 0 F 04 41	G B B A	X 0 F 04 42	G B B A
XOF-2/0.57	0,56	220	280	X 0 F 05 41	G B B A	X 0 F 05 42	G B B A
XOF-2/0.76	0,75	220	280	X 0 F 06 41	G B B A	X 0 F 06 42	G B B A
XOF-2/0.98	0,92	220	280	X 0 F 07 41	G B B A	X 0 F 07 42	G B B A
XOF-2/1.27	1,26	220	280	X 0 F 09 41	G B B A	X 0 F 09 42	G B B A
XOF-2/1.52	1,48	220	280	X 0 F 11 41	G B B A	X 0 F 11 42	G B B A
XOF-2/2.30	2,28	190	210	X 0 F 13 41	G B B A	X 0 F 13 42	G B B A

P1) Max. working pressure - P3) Max. peak pressure

For heavy-duty applications, it is recommended to check the admissible torque of the shaft

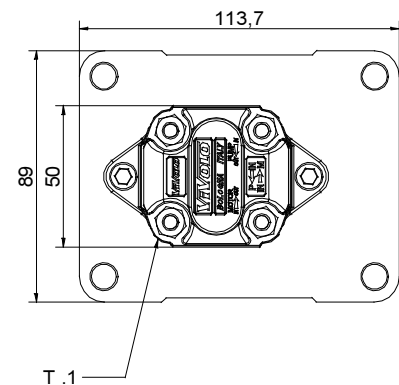

T.1

T.2

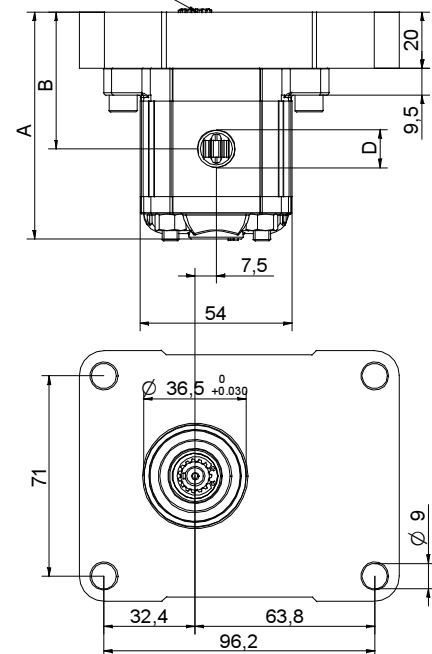

01/04/08 XOF0642GBBA.dft

T.1 = 11.7÷13.7 [Nm] - screw tightening torque M6

T.2 = 2.1 [Nm] - admissible shaft torque (N.B. When choosing a shaft, always check the admissible torque).

Table of variations

XOF-2

Female $\varnothing 36.5$ FLANGE

Female $\varnothing 36.5$ FLANGE		Shaft	
Left rotation	Right rotation		
		CI001 - Parallel T.2 = 2.1 [Nm] 	
41	42	G	

Cover		
Left rotation	Right rotation	
		A
		B
		C
		D
		N
		O

Displacement	
TYPE	CODE
XOF-2/0.17	01
XOF-2/0.25	02
XOF-2/0.45	04
XOF-2/0.57	05
XOF-2/0.76	06
XOF-2/0.98	07
XOF-2/1.27	09
XOF-2/1.52	11
XOF-2/2.30	13

Standard bodies				
Displacement cm ³ /rev	Standard threads			
	0.17	B - B	Z - B	Z - Z
0.25	B - B	Z - B	Z - Z	
0.45	B - B	Z - B	Z - Z	
0.57	B - B	Z - B	Z - Z	
0.76	B - B	Z - B	Z - Z	
0.98	B - B	Z - B	Z - Z	
1.27	B - B	Z - B	Z - Z	
1.52	B - B	Z - B	Z - Z	
2.30	B - B	Z - B	Z - Z	

Table showing standard flange and thread combinations available in stock

Body (threads/flanges)													
	A		B		C		D		E		F		G
	H		I	Closed Body		Z							

entrainment pump - series XV

EUROPEAN STANDARD DRIVING PUMP
 ø25.4 FLANGE - TAPER SHAFT

X1T

X 1 T 25 02 F I I A

Series	X	series XV
Group	1	group 1
Category	T	entrainment pump
Displacement	25	3.8
Flange	02	Ø25.4 STANDARD EUROPEAN right rotation
Shaft	F	COP01 - Tapered 1:8 - ø10 - M7x1 - key thk.2.4
Body	IN	inlet - Ø30 Ø12 M6
	OUT	outlet - Ø30 Ø12 M6
Cover	A	ø25,5 female cover for left multiple pump element

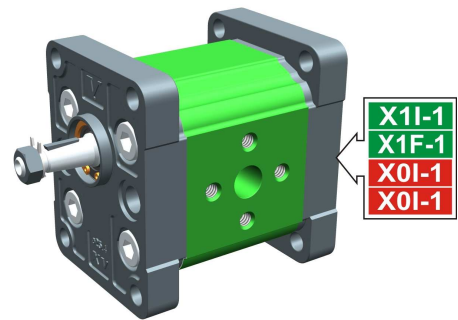

XT101

Technical data table

TYPE	Displacement cm3/rev	Max. Pressure		CODE	
		P1 bar	P3 bar	Left rotation	Right rotation
X1T/0.9	0,91	240	280	X 1 T 16 01 F I I A	X 1 T 16 02 F I I A
X1T/1.2	1,17	250	290	X 1 T 17 01 F I I A	X 1 T 17 02 F I I A
X1T/1.7	1,56	250	290	X 1 T 18 01 F I I A	X 1 T 18 02 F I I A
X1T/2.2	2,08	250	290	X 1 T 20 01 F I I A	X 1 T 20 02 F I I A
X1T/2.6	2,60	250	300	X 1 T 21 01 F I I A	X 1 T 21 02 F I I A
X1T/3.2	3,12	250	300	X 1 T 23 01 F I I A	X 1 T 23 02 F I I A
X1T/3.8	3,64	250	300	X 1 T 25 01 F I I A	X 1 T 25 02 F I I A
X1T/4.3	4,16	250	300	X 1 T 27 01 F I I A	X 1 T 27 02 F I I A
X1T/4.9	4,94	250	300	X 1 T 29 01 F I I A	X 1 T 29 02 F I I A
X1T/5.9	5,85	250	300	X 1 T 31 01 F I I A	X 1 T 31 02 F I I A
X1T/6.5	6,50	250	300	X 1 T 32 01 F I I A	X 1 T 32 02 F I I A
X1T/7.8	7,54	220	260	X 1 T 34 01 F I I A	X 1 T 34 02 F I I A
X1T/9.8	9,88	190	230	X 1 T 36 01 F I I A	X 1 T 36 02 F I I A

P1) Max. working pressure - P3) Max. peak pressure

For heavy-duty applications, it is recommended to check the admissible torque of the shaft

Dimensions table

TYPE	Weight kg	A	B	D	E	F	D	E	F
		mm	mm	IN			OUT		
X1T/0.9	0,950	74,5	37,3	ø12	30	M6x1	ø12	30	M6x1
X1T/1.2	0,970	75,5	37,8	ø12	30	M6x1	ø12	30	M6x1
X1T/1.7	1,010	77,0	38,5	ø12	30	M6x1	ø12	30	M6x1
X1T/2.2	1,030	79,0	39,5	ø12	30	M6x1	ø12	30	M6x1
X1T/2.6	1,060	81,0	40,5	ø12	30	M6x1	ø12	30	M6x1
X1T/3.2	1,090	83,0	41,5	ø12	30	M6x1	ø12	30	M6x1
X1T/3.8	1,120	85,0	42,5	ø12	30	M6x1	ø12	30	M6x1
X1T/4.3	1,170	87,0	43,5	ø12	30	M6x1	ø12	30	M6x1
X1T/4.9	1,200	90,0	45,0	ø12	30	M6x1	ø12	30	M6x1
X1T/5.9	1,260	93,5	46,8	ø12	30	M6x1	ø12	30	M6x1
X1T/6.5	1,300	96,0	48,0	ø12	30	M6x1	ø12	30	M6x1
X1T/7.8	1,360	100,0	50,0	ø12	30	M6x1	ø12	30	M6x1
X1T/9.8	1,500	109,0	54,5	ø12	30	M6x1	ø12	30	M6x1

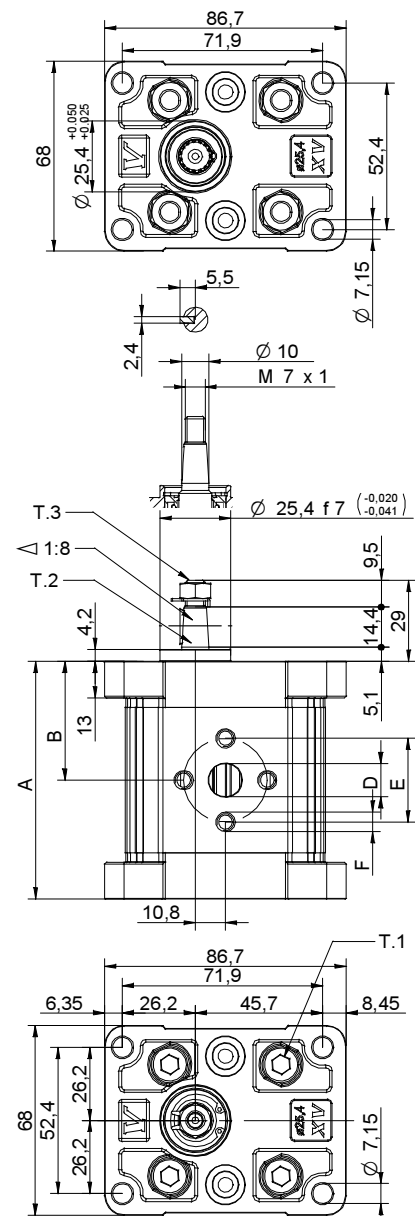

0104/08 X1T2502FIIA.dft

T.1 = 24.5÷29.4 [Nm] - screw tightening torque M8

T.2 = 43.1 [Nm] - admissible shaft torque (N.B. When choosing a shaft, always check the admissible torque).

Table of variations

X1T

ø25.4 FLANGE

ø25.4 FLANGE				Shaft				Cover		
Left rotation		Right rotation						Left rotation	Right rotation	
	01		02	COP01 - Tapered T.2 = 43.1 [Nm] 	F	CFP02 - Milled shank T.2 = 13.8 [Nm] 	D			A
	03		04	SCP04 - Splined T.2 = 22.6 [Nm] m=1.6 Z=6 DIN 5482 - 12x9 	J	SCF02 - Splined T.2 = 42.8 [Nm] m=0.75 Z=15 	L			D
	05		06	SCF01 - Splined T.2 = 42.8 [Nm] m=0.75 Z=15 	Q	SCF03 - Splined T.2 = 42.8 [Nm] m=0.75 Z=15 	R			
	07		08							

Displacement	
TYPE	CODE
X1T/0.9	16
X1T/1.2	17
X1T/1.7	18
X1T/2.2	20
X1T/2.6	21
X1T/3.2	23
X1T/3.8	25
X1T/4.3	27
X1T/4.9	29
X1T/5.9	31
X1T/6.5	32
X1T/7.8	34
X1T/9.8	36

Standard bodies							
Displacement cm3/rev	Standard threads						
	0.9	I - I	B - B	J - J	B - Z	Z - Z	G - F
1.2	I - I	B - B	J - J	B - Z	Z - Z	G - F	
1.7	I - I	B - B	J - J	B - Z	Z - Z	G - F	
2.2	I - I	B - B	J - J	B - Z	Z - Z	G - F	
2.6	I - I	B - B	J - J	B - Z	Z - Z	G - F	
3.2	I - I	B - B	J - J	B - Z	Z - Z	G - F	
3.8	I - I	B - B	J - J	B - Z	Z - Z	G - F	
4.3	I - I	B - B	J - J	B - Z	Z - Z	G - F	
4.9	I - I	B - B	J - J	B - Z	Z - Z	G - F	
5.9	I - I	B - B	J - J	B - Z	Z - Z	G - F	
6.5	I - I	B - B	J - J	B - Z	Z - Z	G - F	
7.8	I - I	B - B	J - J	B - Z	Z - Z	G - F	
9.8	I - I	B - B	J - J	B - Z	Z - Z	G - F	

Table showing standard flange and thread combinations available in stock

Body (threads/flanges)													
	A		B		C		D		E		F		G
	H		I		J	Closed Body	Z						

entrainment pump - series XV

X1T

STANDARD DRIVING PUMP
ø30 FLANGE - TAPER SHAFT

X 1 T 25 12 G I I A

Series	X	series XV
Group	1	group 1
Category	T	entrainment pump
Displacement	25	3.8
Flange	12	Ø30 STANDARD right rotation
Shaft	G	COP02 - Tapered 1:8 - ø14 - M10x1 - key thk.3
Body	IN OUT	inlet - Ø30 Ø12 M6 outlet - Ø30 Ø12 M6
Cover	A	ø25,5 female cover for left multiple pump element

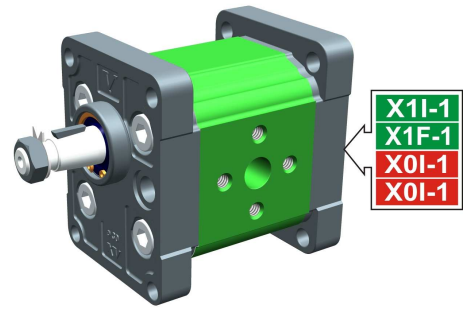

XT113

Technical data table

TYPE	Displacement cm3/rev	Max. Pressure		CODE	
		P1 bar	P3 bar	Left rotation	Right rotation
X1T/0.9	0,91	240	280	X 1 T 16 11 G I I A	X 1 T 16 12 G I I A
X1T/1.2	1,17	250	290	X 1 T 17 11 G I I A	X 1 T 17 12 G I I A
X1T/1.7	1,56	250	290	X 1 T 18 11 G I I A	X 1 T 18 12 G I I A
X1T/2.2	2,08	250	290	X 1 T 20 11 G I I A	X 1 T 20 12 G I I A
X1T/2.6	2,60	250	300	X 1 T 21 11 G I I A	X 1 T 21 12 G I I A
X1T/3.2	3,12	250	300	X 1 T 23 11 G I I A	X 1 T 23 12 G I I A
X1T/3.8	3,64	250	300	X 1 T 25 11 G I I A	X 1 T 25 12 G I I A
X1T/4.3	4,16	250	300	X 1 T 27 11 G I I A	X 1 T 27 12 G I I A
X1T/4.9	4,94	250	300	X 1 T 29 11 G I I A	X 1 T 29 12 G I I A
X1T/5.9	5,85	250	300	X 1 T 31 11 G I I A	X 1 T 31 12 G I I A
X1T/6.5	6,50	250	300	X 1 T 32 11 G I I A	X 1 T 32 12 G I I A
X1T/7.8	7,54	220	260	X 1 T 34 11 G I I A	X 1 T 34 12 G I I A
X1T/9.8	9,88	190	230	X 1 T 36 11 G I I A	X 1 T 36 12 G I I A

P1) Max. working pressure - P3) Max. peak pressure

For heavy-duty applications, it is recommended to check the admissible torque of the shaft

Dimensions table

TYPE	Weight kg	A	B	D	E	F	D	E	F
		mm	mm	IN			OUT		
X1T/0.9	0,950	74,5	37,3	ø12	30	M6x1	ø12	30	M6x1
X1T/1.2	0,970	75,5	37,8	ø12	30	M6x1	ø12	30	M6x1
X1T/1.7	1,010	77,0	38,5	ø12	30	M6x1	ø12	30	M6x1
X1T/2.2	1,030	79,0	39,5	ø12	30	M6x1	ø12	30	M6x1
X1T/2.6	1,060	81,0	40,5	ø12	30	M6x1	ø12	30	M6x1
X1T/3.2	1,090	83,0	41,5	ø12	30	M6x1	ø12	30	M6x1
X1T/3.8	1,120	85,0	42,5	ø12	30	M6x1	ø12	30	M6x1
X1T/4.3	1,170	87,0	43,5	ø12	30	M6x1	ø12	30	M6x1
X1T/4.9	1,200	90,0	45,0	ø12	30	M6x1	ø12	30	M6x1
X1T/5.9	1,260	93,5	46,8	ø12	30	M6x1	ø12	30	M6x1
X1T/6.5	1,300	96,0	48,0	ø12	30	M6x1	ø12	30	M6x1
X1T/7.8	1,360	100,0	50,0	ø12	30	M6x1	ø12	30	M6x1
X1T/9.8	1,500	109,0	54,5	ø12	30	M6x1	ø12	30	M6x1

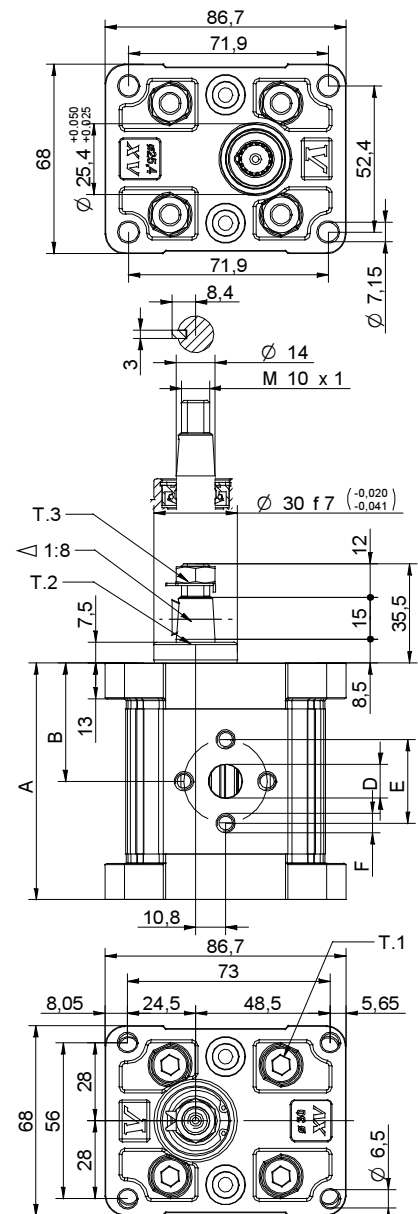

01/04/08 XT125G6IIA.dft

T.1 = 24.5÷29.4 [Nm] - screw tightening torque M8

T.3 = 13 [Nm] - torque wrench setting 17

T.2 = 119.8 [Nm] - admissible shaft torque (N.B. When choosing a shaft, always check the admissible torque).

Table of variations

X1T

ø30 FLANGE

ø30 FLANGE				Shaft				Cover			
Left rotation		Right rotation						Left rotation		Right rotation	
	11		12	CIP01 - Parallel T.2 = 25.8 [Nm] 	A	COP02 - Tapered T.2 = 119.8 [Nm] 	G			A	
	13		14	CI001+HK - Parallel T.2 = 25.8 [Nm] 	P	COP02+HK - Tapered T.2 = 119.8 [Nm] 	O			D	
	15		16								
	17		18								

Displacement	
TYPE	CODE
X1T/0.9	16
X1T/1.2	17
X1T/1.7	18
X1T/2.2	20
X1T/2.6	21
X1T/3.2	23
X1T/3.8	25
X1T/4.3	27
X1T/4.9	29
X1T/5.9	31
X1T/6.5	32
X1T/7.8	34
X1T/9.8	36

Standard bodies							
Displacement cm3/rev	Standard threads						
	0.9	I - I	B - B	J - J	B - Z	Z - Z	G - F
1.2	I - I	B - B	J - J	B - Z	Z - Z	G - F	
1.7	I - I	B - B	J - J	B - Z	Z - Z	G - F	
2.2	I - I	B - B	J - J	B - Z	Z - Z	G - F	
2.6	I - I	B - B	J - J	B - Z	Z - Z	G - F	
3.2	I - I	B - B	J - J	B - Z	Z - Z	G - F	
3.8	I - I	B - B	J - J	B - Z	Z - Z	G - F	
4.3	I - I	B - B	J - J	B - Z	Z - Z	G - F	
4.9	I - I	B - B	J - J	B - Z	Z - Z	G - F	
5.9	I - I	B - B	J - J	B - Z	Z - Z	G - F	
6.5	I - I	B - B	J - J	B - Z	Z - Z	G - F	
7.8	I - I	B - B	J - J	B - Z	Z - Z	G - F	
9.8	I - I	B - B	J - J	B - Z	Z - Z	G - F	

Table showing standard flange and thread combinations available in stock

Body (threads/flanges)													
	A		B		C		D		E		F		G
	H		I		J	Closed Body	Z						

entrainment pump - series XV

X1T

"BH" DRIVING PUMP
 ø32 BODY-SHAPED FLANGE - MILLED SHANK

X 1 T 25 42 D B B A

Series	X	series XV
Group	1	group 1
Category	T	entrainment pump
Displacement	25	3.8
Flange	42	Ø32 BH right rotation
Shaft	D	CFP02 - Milled shank ø10 - thk.5
Body	IN	inlet - 3/8" GAS
	OUT	outlet - 3/8" GAS
Cover	A	ø25,5 female cover for left multiple pump element

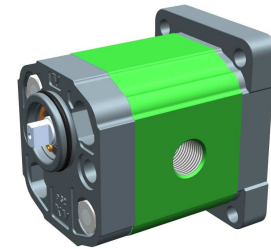

X1I-1
 X1F-1
 X0I-1
 X0I-1

XT119

Technical data table						
TYPE	Displacement cm3/rev	Max. Pressure		CODE		
		P1 bar	P3 bar	Left rotation		Right rotation
X1T/0.9	0,91	240	280	X 1 T 16 41	D B B A	X 1 T 16 42 D B B A
X1T/1.2	1,17	250	290	X 1 T 17 41	D B B A	X 1 T 17 42 D B B A
X1T/1.7	1,56	250	290	X 1 T 18 41	D B B A	X 1 T 18 42 D B B A
X1T/2.2	2,08	250	290	X 1 T 20 41	D B B A	X 1 T 20 42 D B B A
X1T/2.6	2,60	250	300	X 1 T 21 41	D B B A	X 1 T 21 42 D B B A
X1T/3.2	3,12	250	300	X 1 T 23 41	D B B A	X 1 T 23 42 D B B A
X1T/3.8	3,64	250	300	X 1 T 25 41	D B B A	X 1 T 25 42 D B B A
X1T/4.3	4,16	250	300	X 1 T 27 41	D B B A	X 1 T 27 42 D B B A
X1T/4.9	4,94	250	300	X 1 T 29 41	D B B A	X 1 T 29 42 D B B A
X1T/5.9	5,85	250	300	X 1 T 31 41	D B B A	X 1 T 31 42 D B B A
X1T/6.5	6,50	250	300	X 1 T 32 41	D B B A	X 1 T 32 42 D B B A
X1T/7.8	7,54	220	260	X 1 T 34 41	D B B A	X 1 T 34 42 D B B A
X1T/9.8	9,88	190	230	X 1 T 36 41	D B B A	X 1 T 36 42 D B B A

P1) Max. working pressure - P3) Max. peak pressure

For heavy-duty applications, it is recommended to check the admissible torque of the shaft

Dimensions table					
TYPE	Weight	A	B	D	D
	kg	mm	mm	IN	OUT
X1T/0.9	0,950	73,5	36,3	3/8" BSPP	3/8" BSPP
X1T/1.2	0,970	74,5	36,8	3/8" BSPP	3/8" BSPP
X1T/1.7	1,010	76,0	37,5	3/8" BSPP	3/8" BSPP
X1T/2.2	1,030	78,0	38,5	3/8" BSPP	3/8" BSPP
X1T/2.6	1,060	80,0	39,5	3/8" BSPP	3/8" BSPP
X1T/3.2	1,090	82,0	40,5	3/8" BSPP	3/8" BSPP
X1T/3.8	1,120	84,0	41,5	3/8" BSPP	3/8" BSPP
X1T/4.3	1,170	86,0	42,5	3/8" BSPP	3/8" BSPP
X1T/4.9	1,200	89,0	44,0	3/8" BSPP	3/8" BSPP
X1T/5.9	1,260	92,5	45,8	3/8" BSPP	3/8" BSPP
X1T/6.5	1,300	95,0	47,0	3/8" BSPP	3/8" BSPP
X1T/7.8	1,360	99,0	49,0	3/8" BSPP	3/8" BSPP
X1T/9.8	1,500	108,0	53,5	3/8" BSPP	3/8" BSPP

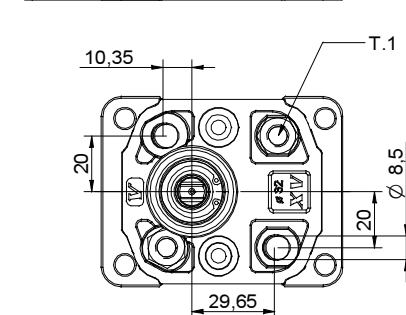
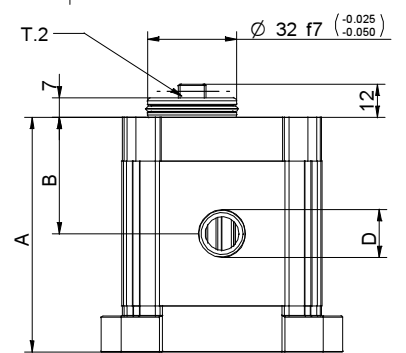
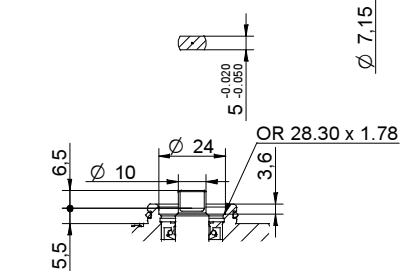
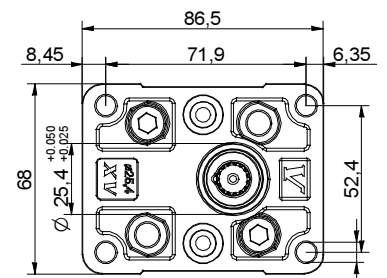

01/04/08 XT1254.208BA.dft

T.1 = 24.5÷29.4 [Nm] - screw tightening torque M8

T.2 = 13.8 [Nm] - admissible shaft torque (N.B. When choosing a shaft, always check the admissible torque).

Table of variations

X1T

ø32 "BH" Body-Shaped FLANGE

ø32 "BH" Body-Shaped FLANGE				Shaft				Cover		
Left rotation		Right rotation						Left rotation	Right rotation	
	41		42	CFP02 - Milled shank T.2 = 13.8 [Nm] 	D	COP01 - Tapered T.2 = 43.1 [Nm] 	F			A
	43		44	SCF02 - Splined T.2 = 42.8 [Nm] m=0,75 Z=15 	L	SCP04 - Splined T.2 = 22.6 [Nm] m=1,6 Z=6 DIN 5482 - 12x9 	J			D
	45		46	SCF01 - Splined T.2 = 42.8 [Nm] m=0,75 Z=15 	Q	SCF03 - Splined T.2 = 42.8 [Nm] m=0,75 Z=15 	R			
	47		48							

Displacement	
TYPE	CODE
X1T/0.9	16
X1T/1.2	17
X1T/1.7	18
X1T/2.2	20
X1T/2.6	21
X1T/3.2	23
X1T/3.8	25
X1T/4.3	27
X1T/4.9	29
X1T/5.9	31
X1T/6.5	32
X1T/7.8	34
X1T/9.8	36

Standard bodies							
Displacement cm3/rev	Standard threads						
	0.9	I - I	B - B	J - J	B - Z	Z - Z	G - F
1.2	I - I	B - B	J - J	B - Z	Z - Z	G - F	
1.7	I - I	B - B	J - J	B - Z	Z - Z	G - F	
2.2	I - I	B - B	J - J	B - Z	Z - Z	G - F	
2.6	I - I	B - B	J - J	B - Z	Z - Z	G - F	
3.2	I - I	B - B	J - J	B - Z	Z - Z	G - F	
3.8	I - I	B - B	J - J	B - Z	Z - Z	G - F	
4.3	I - I	B - B	J - J	B - Z	Z - Z	G - F	
4.9	I - I	B - B	J - J	B - Z	Z - Z	G - F	
5.9	I - I	B - B	J - J	B - Z	Z - Z	G - F	
6.5	I - I	B - B	J - J	B - Z	Z - Z	G - F	
7.8	I - I	B - B	J - J	B - Z	Z - Z	G - F	
9.8	I - I	B - B	J - J	B - Z	Z - Z	G - F	

Table showing standard flange and thread combinations available in stock

Body (threads/flanges)													
	A		B		C		D		E		F		G
	H		I		J	Closed Body	Z						

entrainment pump - series XV

X1T

"HY" DRIVING PUMP
 ø32 BODY-SHAPED FLANGE - MILLED SHANK

X 1 T 25 52 D B B A

Series	X	series XV
Group	1	group 1
Category	T	entrainment pump
Displacement	25	3.8
Flange	52	Ø32 HY right rotation
Shaft	D	CFP02 - Milled shank ø10 - thk.5
Body	IN	inlet - 3/8" GAS
	OUT	outlet - 3/8" GAS
Cover	A	ø25,5 female cover for left multiple pump element

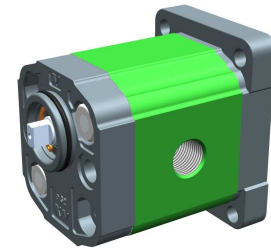

X1I-1
 X1F-1
 X0I-1
 X0I-1

XT140

Technical data table

TYPE	Displacement cm3/rev	Max. Pressure		CODE			
		P1 bar	P3 bar	Left rotation		Right rotation	
X1T/0.9	0,91	240	280	X 1 T 16 51	D B B A	X 1 T 16 52	D B B A
X1T/1.2	1,17	250	290	X 1 T 17 51	D B B A	X 1 T 17 52	D B B A
X1T/1.7	1,56	250	290	X 1 T 18 51	D B B A	X 1 T 18 52	D B B A
X1T/2.2	2,08	250	290	X 1 T 20 51	D B B A	X 1 T 20 52	D B B A
X1T/2.6	2,60	250	300	X 1 T 21 51	D B B A	X 1 T 21 52	D B B A
X1T/3.2	3,12	250	300	X 1 T 23 51	D B B A	X 1 T 23 52	D B B A
X1T/3.8	3,64	250	300	X 1 T 25 51	D B B A	X 1 T 25 52	D B B A
X1T/4.3	4,16	250	300	X 1 T 27 51	D B B A	X 1 T 27 52	D B B A
X1T/4.9	4,94	250	300	X 1 T 29 51	D B B A	X 1 T 29 52	D B B A
X1T/5.9	5,85	250	300	X 1 T 31 51	D B B A	X 1 T 31 52	D B B A
X1T/6.5	6,50	250	300	X 1 T 32 51	D B B A	X 1 T 32 52	D B B A
X1T/7.8	7,54	220	260	X 1 T 34 51	D B B A	X 1 T 34 52	D B B A
X1T/9.8	9,88	190	230	X 1 T 36 51	D B B A	X 1 T 36 52	D B B A

P1) Max. working pressure - P3) Max. peak pressure

For heavy-duty applications, it is recommended to check the admissible torque of the shaft

Dimensions table

TYPE	Weight kg	A	B	D	
		mm	mm	IN	OUT
X1T/0.9	0,950	73,5	36,3	3/8" BSPP	3/8" BSPP
X1T/1.2	0,970	74,5	36,8	3/8" BSPP	3/8" BSPP
X1T/1.7	1,010	76,0	37,5	3/8" BSPP	3/8" BSPP
X1T/2.2	1,030	78,0	38,5	3/8" BSPP	3/8" BSPP
X1T/2.6	1,060	80,0	39,5	3/8" BSPP	3/8" BSPP
X1T/3.2	1,090	82,0	40,5	3/8" BSPP	3/8" BSPP
X1T/3.8	1,120	84,0	41,5	3/8" BSPP	3/8" BSPP
X1T/4.3	1,170	86,0	42,5	3/8" BSPP	3/8" BSPP
X1T/4.9	1,200	89,0	44,0	3/8" BSPP	3/8" BSPP
X1T/5.9	1,260	92,5	45,8	3/8" BSPP	3/8" BSPP
X1T/6.5	1,300	95,0	47,0	3/8" BSPP	3/8" BSPP
X1T/7.8	1,360	99,0	49,0	3/8" BSPP	3/8" BSPP
X1T/9.8	1,500	108,0	53,5	3/8" BSPP	3/8" BSPP

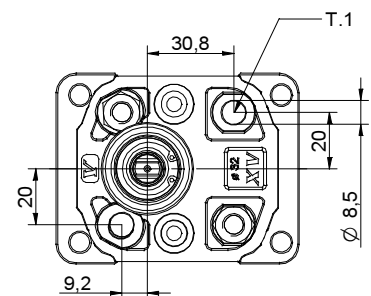
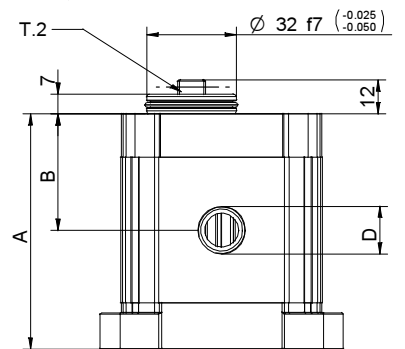
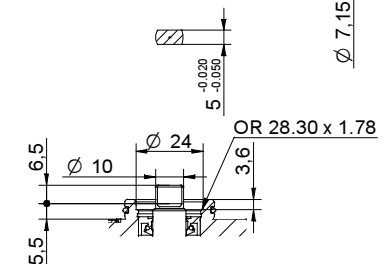
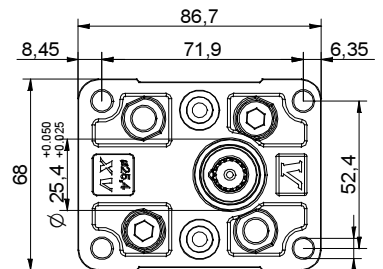

010A/08 XT125520BBA.dft

T.1 = 24.5÷29.4 [Nm] - screw tightening torque M8

T.2 = 13.8 [Nm] - admissible shaft torque (N.B. When choosing a shaft, always check the admissible torque).

Table of variations

X1T

ø32 "HY" Body-Shaped FLANGE

ø32 "HY" Body-Shaped FLANGE				Shaft				Cover		
Left rotation		Right rotation						Left rotation	Right rotation	
	51		52	CFP02 - Milled shank T.2 = 13.8 [Nm] 	D	COP01 - Tapered T.2 = 43.1 [Nm] 	F			A
	53		54	SCF02 - Splined T.2 = 42.8 [Nm] m=0,75 Z=15 	L	SCP04 - Splined T.2 = 22.6 [Nm] m=1,6 Z=6 DIN 5482 - 12x9 	J			D
	55		56	SCF01 - Splined T.2 = 42.8 [Nm] m=0,75 Z=15 	Q	SCF03 - Splined T.2 = 42.8 [Nm] m=0,75 Z=15 	R			
	57		58							

Displacement	
TYPE	CODE
X1T/0.9	16
X1T/1.2	17
X1T/1.7	18
X1T/2.2	20
X1T/2.6	21
X1T/3.2	23
X1T/3.8	25
X1T/4.3	27
X1T/4.9	29
X1T/5.9	31
X1T/6.5	32
X1T/7.8	34
X1T/9.8	36

Standard bodies							
Displacement cm3/rev	Standard threads						
	0.9	I - I	B - B	J - J	B - Z	Z - Z	G - F
1.2	I - I	B - B	J - J	B - Z	Z - Z	G - F	
1.7	I - I	B - B	J - J	B - Z	Z - Z	G - F	
2.2	I - I	B - B	J - J	B - Z	Z - Z	G - F	
2.6	I - I	B - B	J - J	B - Z	Z - Z	G - F	
3.2	I - I	B - B	J - J	B - Z	Z - Z	G - F	
3.8	I - I	B - B	J - J	B - Z	Z - Z	G - F	
4.3	I - I	B - B	J - J	B - Z	Z - Z	G - F	
4.9	I - I	B - B	J - J	B - Z	Z - Z	G - F	
5.9	I - I	B - B	J - J	B - Z	Z - Z	G - F	
6.5	I - I	B - B	J - J	B - Z	Z - Z	G - F	
7.8	I - I	B - B	J - J	B - Z	Z - Z	G - F	
9.8	I - I	B - B	J - J	B - Z	Z - Z	G - F	

Table showing standard flange and thread combinations available in stock

Body (threads/flanges)													
	A		B		C		D		E		F		G
	H		I		J	Closed Body	Z						

entrainment pump - series XV

"BH" GERMAN STANDARD DRIVING PUMP
 ø32 BODY-SHAPED FLANGE - MILLED SHANK

X1T

X 1 T 25 32 C B B A

Series	X	series XV
Group	1	group 1
Category	T	entrainment pump
Displacement	25	3.8
Flange	32	Ø32 BH GERMAN STARDARDIZED right rotation
Shaft	C	CFP01 - Milled shank ø10 - thk.5 ("BH" Standard German)
Body	IN	inlet - 3/8" GAS
	OUT	outlet - 3/8" GAS
Cover	A	ø25,5 female cover for left multiple pump element

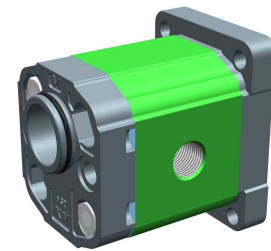

X1I-1
 X1F-1
 X0I-1
 X0I-1

XT161

Technical data table						
TYPE	Displacement cm3/rev	Max. Pressure		CODE		
		P1 bar	P3 bar	Left rotation		Right rotation
X1T/0.9	0,91	240	280	X 1 T 16 31	C B B A	X 1 T 16 32 C B B A
X1T/1.2	1,17	250	290	X 1 T 17 31	C B B A	X 1 T 17 32 C B B A
X1T/1.7	1,56	250	290	X 1 T 18 31	C B B A	X 1 T 18 32 C B B A
X1T/2.2	2,08	250	290	X 1 T 20 31	C B B A	X 1 T 20 32 C B B A
X1T/2.6	2,60	250	300	X 1 T 21 31	C B B A	X 1 T 21 32 C B B A
X1T/3.2	3,12	250	300	X 1 T 23 31	C B B A	X 1 T 23 32 C B B A
X1T/3.8	3,64	250	300	X 1 T 25 31	C B B A	X 1 T 25 32 C B B A
X1T/4.3	4,16	250	300	X 1 T 27 31	C B B A	X 1 T 27 32 C B B A
X1T/4.9	4,94	250	300	X 1 T 29 31	C B B A	X 1 T 29 32 C B B A
X1T/5.9	5,85	250	300	X 1 T 31 31	C B B A	X 1 T 31 32 C B B A
X1T/6.5	6,50	250	300	X 1 T 32 31	C B B A	X 1 T 32 32 C B B A
X1T/7.8	7,54	220	260	X 1 T 34 31	C B B A	X 1 T 34 32 C B B A
X1T/9.8	9,88	190	230	X 1 T 36 31	C B B A	X 1 T 36 32 C B B A

P1) Max. working pressure - P3) Max. peak pressure

For heavy-duty applications, it is recommended to check the admissible torque of the shaft

Dimensions table					
TYPE	Weight kg	A	B	D	D
		mm	mm	IN	OUT
X1T/0.9	0,950	73,5	36,3	3/8" BSPP	3/8" BSPP
X1T/1.2	0,970	74,5	36,8	3/8" BSPP	3/8" BSPP
X1T/1.7	1,010	76,0	37,5	3/8" BSPP	3/8" BSPP
X1T/2.2	1,030	78,0	38,5	3/8" BSPP	3/8" BSPP
X1T/2.6	1,060	80,0	39,5	3/8" BSPP	3/8" BSPP
X1T/3.2	1,090	82,0	40,5	3/8" BSPP	3/8" BSPP
X1T/3.8	1,120	84,0	41,5	3/8" BSPP	3/8" BSPP
X1T/4.3	1,170	86,0	42,5	3/8" BSPP	3/8" BSPP
X1T/4.9	1,200	89,0	44,0	3/8" BSPP	3/8" BSPP
X1T/5.9	1,260	92,5	45,8	3/8" BSPP	3/8" BSPP
X1T/6.5	1,300	95,0	47,0	3/8" BSPP	3/8" BSPP
X1T/7.8	1,360	99,0	49,0	3/8" BSPP	3/8" BSPP
X1T/9.8	1,500	108,0	53,5	3/8" BSPP	3/8" BSPP

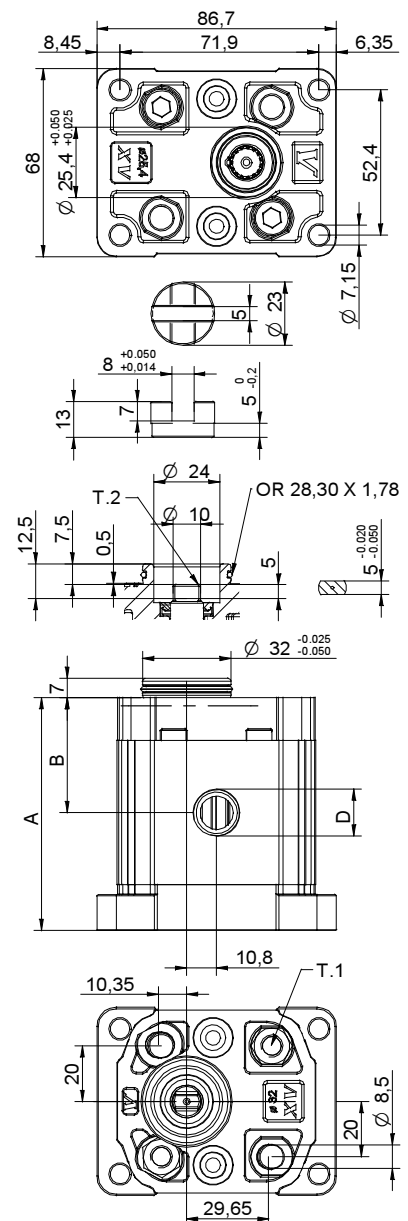

T.1 = 24.5÷29.4 [Nm] - screw tightening torque M8

T.2 = 13.8 [Nm] - admissible shaft torque (N.B. When choosing a shaft, always check the admissible torque).

Table of variations

X1T

Standard German $\varnothing 32$ "BH" FLANGE

Standard German $\varnothing 32$ "BH" FLANGE				Shaft		Cover		
Left rotation		Right rotation				Left rotation	Right rotation	
	31		32	CFP01 - Milled shank T.2 = 13.8 [Nm]	C	SCF01 - Splined T.2 = 42.8 [Nm]		A
	33		34	SCF03 - Splined T.2 = 42.8 [Nm]	R			D
	35		36					
	37		38					

Displacement	
TYPE	CODE
X1T/0.9	16
X1T/1.2	17
X1T/1.7	18
X1T/2.2	20
X1T/2.6	21
X1T/3.2	23
X1T/3.8	25
X1T/4.3	27
X1T/4.9	29
X1T/5.9	31
X1T/6.5	32
X1T/7.8	34
X1T/9.8	36

Standard bodies							
Displacement cm3/rev	Standard threads						
	0.9	I - I	B - B	J - J	B - Z	Z - Z	G - F
1.2	I - I	B - B	J - J	B - Z	Z - Z	G - F	
1.7	I - I	B - B	J - J	B - Z	Z - Z	G - F	
2.2	I - I	B - B	J - J	B - Z	Z - Z	G - F	
2.6	I - I	B - B	J - J	B - Z	Z - Z	G - F	
3.2	I - I	B - B	J - J	B - Z	Z - Z	G - F	
3.8	I - I	B - B	J - J	B - Z	Z - Z	G - F	
4.3	I - I	B - B	J - J	B - Z	Z - Z	G - F	
4.9	I - I	B - B	J - J	B - Z	Z - Z	G - F	
5.9	I - I	B - B	J - J	B - Z	Z - Z	G - F	
6.5	I - I	B - B	J - J	B - Z	Z - Z	G - F	
7.8	I - I	B - B	J - J	B - Z	Z - Z	G - F	
9.8	I - I	B - B	J - J	B - Z	Z - Z	G - F	

Table showing standard flange and thread combinations available in stock

Body (threads/flanges)													
	A		B		C		D		E		F		G
	H		I		J	Closed Body	Z						

entrainment pump - series XV

"SAE AA" DRIVING PUMP

X1T

X 1 T 25 62 B B B A

Series	X	series XV
Group	1	group 1
Category	T	entrainment pump
Displacement	25	3.8
Flange	62	Ø50.8 SAE AA right rotation
Shaft	B	CIP02 - Parallel ø12.7 - key thk. 3.2 (SAE AA)
Body	IN	inlet - 3/8" GAS
	OUT	outlet - 3/8" GAS
Cover	A	ø25,5 female cover for left multiple pump element

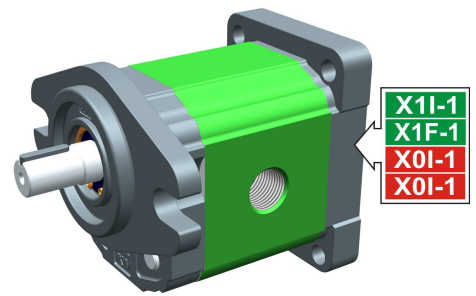

XT168

Technical data table

TYPE	Displacement cm3/rev	Max. Pressure		CODE	
		P1 bar	P3 bar	Left rotation	Right rotation
X1T/0.9	0,91	240	280	X 1 T 16 61 B B B A	X 1 T 16 62 B B B A
X1T/1.2	1,17	250	290	X 1 T 17 61 B B B A	X 1 T 17 62 B B B A
X1T/1.7	1,56	250	290	X 1 T 18 61 B B B A	X 1 T 18 62 B B B A
X1T/2.2	2,08	250	290	X 1 T 20 61 B B B A	X 1 T 20 62 B B B A
X1T/2.6	2,60	250	300	X 1 T 21 61 B B B A	X 1 T 21 62 B B B A
X1T/3.2	3,12	250	300	X 1 T 23 61 B B B A	X 1 T 23 62 B B B A
X1T/3.8	3,64	250	300	X 1 T 25 61 B B B A	X 1 T 25 62 B B B A
X1T/4.3	4,16	250	300	X 1 T 27 61 B B B A	X 1 T 27 62 B B B A
X1T/4.9	4,94	250	300	X 1 T 29 61 B B B A	X 1 T 29 62 B B B A
X1T/5.9	5,85	250	300	X 1 T 31 61 B B B A	X 1 T 31 62 B B B A
X1T/6.5	6,50	250	300	X 1 T 32 61 B B B A	X 1 T 32 62 B B B A
X1T/7.8	7,54	220	260	X 1 T 34 61 B B B A	X 1 T 34 62 B B B A
X1T/9.8	9,88	190	230	X 1 T 36 61 B B B A	X 1 T 36 62 B B B A

P1) Max. working pressure - P3) Max. peak pressure

For heavy-duty applications, it is recommended to check the admissible torque of the shaft

Dimensions table

TYPE	Weight kg	A	B	D	D
		mm	mm	IN	OUT
X1T/0.9	1,000	79,0	41,8	3/8" BSPP	3/8" BSPP
X1T/1.2	1,020	80,0	42,3	3/8" BSPP	3/8" BSPP
X1T/1.7	1,060	81,5	43,0	3/8" BSPP	3/8" BSPP
X1T/2.2	1,080	83,5	44,0	3/8" BSPP	3/8" BSPP
X1T/2.6	1,110	85,5	45,0	3/8" BSPP	3/8" BSPP
X1T/3.2	1,140	87,5	46,0	3/8" BSPP	3/8" BSPP
X1T/3.8	1,170	89,5	47,0	3/8" BSPP	3/8" BSPP
X1T/4.3	1,220	91,5	48,0	3/8" BSPP	3/8" BSPP
X1T/4.9	1,250	94,5	49,5	3/8" BSPP	3/8" BSPP
X1T/5.9	1,310	98,0	51,3	3/8" BSPP	3/8" BSPP
X1T/6.5	1,350	100,5	52,5	3/8" BSPP	3/8" BSPP
X1T/7.8	1,410	104,5	54,5	3/8" BSPP	3/8" BSPP
X1T/9.8	1,550	113,5	59,0	3/8" BSPP	3/8" BSPP

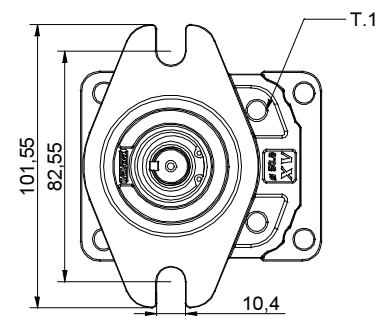
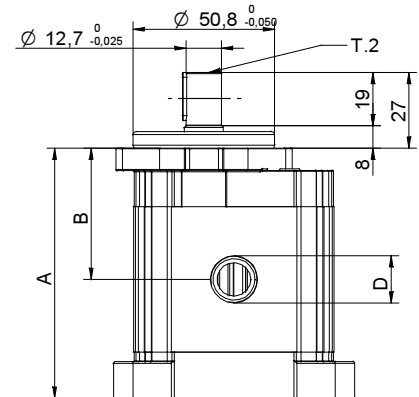
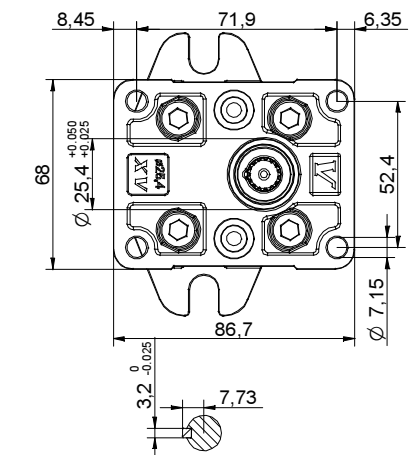

010/0/08 XT12562888A.dft

T.1 = 24.5÷29.4 [Nm] - screw tightening torque M8

T.2 = 32.8 [Nm] - admissible shaft torque (N.B. When choosing a shaft, always check the admissible torque).

Table of variations

X1T

ø50.8 FLANGE "SAE AA"

ø50.8 FLANGE "SAE AA"		Shaft		Cover				
Left rotation	Right rotation			Left rotation	Right rotation			
		CIP01 - Parallel T.2 = 25.8 [Nm] 	A	CIP02 - Parallel T.2 = 32.8 [Nm] SAE 3.2 	B			A
61	62	CFP03 - Milled shank T.2 = 25.9 [Nm] SAE 	E	COP02 - Tapered T.2 = 119.8 [Nm] 	G			D
		CO004 - Tapered T.2 = 90.4 [Nm] SAE 	I	SCF05 - Splined T.2 = 32.2 [Nm] SAE J 498 9T 20/40 DP 	K			
		COP02+HK - Tapered T.2 = 119.8 [Nm] HK 14-12 	O	CI001+HK - Parallel T.2 = 25.8 [Nm] HK 14-12 	P			

Displacement	
TYPE	CODE
X1T/0.9	16
X1T/1.2	17
X1T/1.7	18
X1T/2.2	20
X1T/2.6	21
X1T/3.2	23
X1T/3.8	25
X1T/4.3	27
X1T/4.9	29
X1T/5.9	31
X1T/6.5	32
X1T/7.8	34
X1T/9.8	36

Standard bodies							
Displacement cm3/rev	Standard threads						
	0.9	I - I	B - B	J - J	B - Z	Z - Z	G - F
1.2	I - I	B - B	J - J	B - Z	Z - Z	G - F	
1.7	I - I	B - B	J - J	B - Z	Z - Z	G - F	
2.2	I - I	B - B	J - J	B - Z	Z - Z	G - F	
2.6	I - I	B - B	J - J	B - Z	Z - Z	G - F	
3.2	I - I	B - B	J - J	B - Z	Z - Z	G - F	
3.8	I - I	B - B	J - J	B - Z	Z - Z	G - F	
4.3	I - I	B - B	J - J	B - Z	Z - Z	G - F	
4.9	I - I	B - B	J - J	B - Z	Z - Z	G - F	
5.9	I - I	B - B	J - J	B - Z	Z - Z	G - F	
6.5	I - I	B - B	J - J	B - Z	Z - Z	G - F	
7.8	I - I	B - B	J - J	B - Z	Z - Z	G - F	
9.8	I - I	B - B	J - J	B - Z	Z - Z	G - F	

Table showing standard flange and thread combinations available in stock

Body (threads/flanges)													
	A		B		C		D		E		F		G
	H		I		J	Closed Body	Z						

intermediate pump - series XV

X11-1

STANDARD INTERMEDIATE PUMP
FEMALE Ø25,4 FLANGE

X 1 I 25 72 S I I A

Series	X	series XV
Group	1	group 1
Category	I	intermediate pump
Displacement	25	3.8
Flange	72	Ø25.4 female right rotation 1P+1P
Shaft	S	SCI01 - Intermediate
Body	IN	inlet - Ø30 Ø12 M6
	OUT	outlet - Ø30 Ø12 M6
Cover	A	Ø25,5 female cover for left multiple pump element

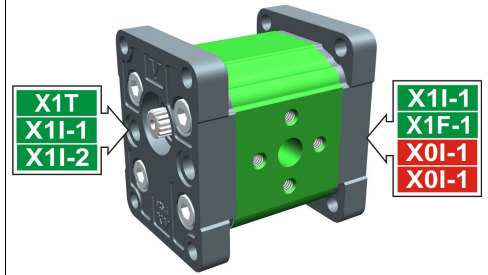

XI101

Technical data table

TYPE	Displacement cm3/rev	Max. Pressure		CODE																	
		P1 bar	P3 bar	Left rotation			Right rotation														
X11-1/0.9	0,91	240	280	X	1	I	16	71	S	I	I	A	X	1	I	16	72	S	I	I	A
X11-1/1.2	1,17	250	290	X	1	I	17	71	S	I	I	A	X	1	I	17	72	S	I	I	A
X11-1/1.7	1,56	250	290	X	1	I	18	71	S	I	I	A	X	1	I	18	72	S	I	I	A
X11-1/2.2	2,08	250	290	X	1	I	20	71	S	I	I	A	X	1	I	20	72	S	I	I	A
X11-1/2.6	2,60	250	300	X	1	I	21	71	S	I	I	A	X	1	I	21	72	S	I	I	A
X11-1/3.2	3,12	250	300	X	1	I	23	71	S	I	I	A	X	1	I	23	72	S	I	I	A
X11-1/3.8	3,64	250	300	X	1	I	25	71	S	I	I	A	X	1	I	25	72	S	I	I	A
X11-1/4.3	4,16	250	300	X	1	I	27	71	S	I	I	A	X	1	I	27	72	S	I	I	A
X11-1/4.9	4,94	250	300	X	1	I	29	71	S	I	I	A	X	1	I	29	72	S	I	I	A
X11-1/5.9	5,85	250	300	X	1	I	31	71	S	I	I	A	X	1	I	31	72	S	I	I	A
X11-1/6.5	6,50	250	300	X	1	I	32	71	S	I	I	A	X	1	I	32	72	S	I	I	A
X11-1/7.8	7,54	220	260	X	1	I	34	71	S	I	I	A	X	1	I	34	72	S	I	I	A
X11-1/9.8	9,88	190	230	X	1	I	36	71	S	I	I	A	X	1	I	36	72	S	I	I	A

P1) Max. working pressure - P3) Max. peak pressure

For heavy-duty applications, it is recommended to check the admissible torque of the shaft

Dimensions table

TYPE	Weight kg	A mm	B mm	IN			OUT		
				D	E	F	D	E	F
X11-1/0.9	0,950	74,5	37,3	Ø12	30	M6x1	Ø12	30	M6x1
X11-1/1.2	0,970	75,5	37,8	Ø12	30	M6x1	Ø12	30	M6x1
X11-1/1.7	1,010	77,0	38,5	Ø12	30	M6x1	Ø12	30	M6x1
X11-1/2.2	1,030	79,0	39,5	Ø12	30	M6x1	Ø12	30	M6x1
X11-1/2.6	1,060	81,0	40,5	Ø12	30	M6x1	Ø12	30	M6x1
X11-1/3.2	1,090	83,0	41,5	Ø12	30	M6x1	Ø12	30	M6x1
X11-1/3.8	1,120	85,0	42,5	Ø12	30	M6x1	Ø12	30	M6x1
X11-1/4.3	1,170	87,0	43,5	Ø12	30	M6x1	Ø12	30	M6x1
X11-1/4.9	1,200	90,0	45,0	Ø12	30	M6x1	Ø12	30	M6x1
X11-1/5.9	1,260	93,5	46,8	Ø12	30	M6x1	Ø12	30	M6x1
X11-1/6.5	1,300	96,0	48,0	Ø12	30	M6x1	Ø12	30	M6x1
X11-1/7.8	1,360	100,0	50,0	Ø12	30	M6x1	Ø12	30	M6x1
X11-1/9.8	1,500	109,0	54,5	Ø12	30	M6x1	Ø12	30	M6x1

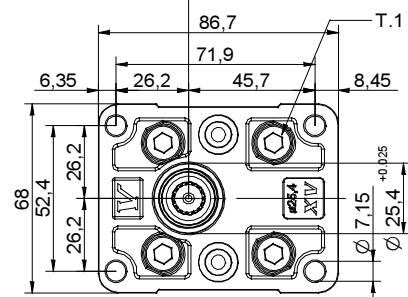
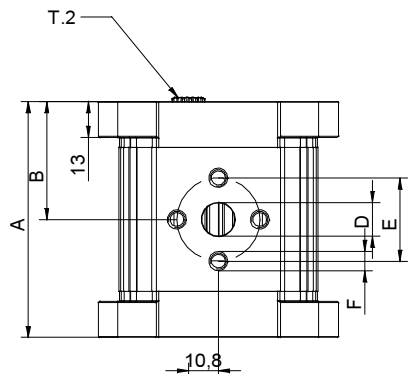
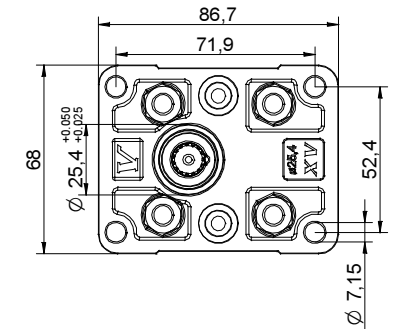

0104/08 XI12572SIIA.dft

T.1 = 24.5÷29.4 [Nm] - screw tightening torque M8

T.2 = 42.8 [Nm] - admissible shaft torque (N.B. When choosing a shaft, always check the admissible torque).

Table of variations

X11-1

Standard female $\phi 25,4$ FLANGE

Standard female $\phi 25,4$ FLANGE				Shaft		Cover		
Left rotation		Right rotation				Left rotation	Right rotation	
	71		72	SCI01 - Splined $T.2 = 42.8$ [Nm] $m=0,75$ $Z=15$ 				A
								D

Displacement	
TYPE	CODE
X11-1/0.9	16
X11-1/1.2	17
X11-1/1.7	18
X11-1/2.2	20
X11-1/2.6	21
X11-1/3.2	23
X11-1/3.8	25
X11-1/4.3	27
X11-1/4.9	29
X11-1/5.9	31
X11-1/6.5	32
X11-1/7.8	34
X11-1/9.8	36

Standard bodies				
Displacement cm3/rev	Standard threads			
	0.9	I - I	B - B	J - J
1.2	I - I	B - B	J - J	G - F
1.7	I - I	B - B	J - J	G - F
2.2	I - I	B - B	J - J	G - F
2.6	I - I	B - B	J - J	G - F
3.2	I - I	B - B	J - J	G - F
3.8	I - I	B - B	J - J	G - F
4.3	I - I	B - B	J - J	G - F
4.9	I - I	B - B	J - J	G - F
5.9	I - I	B - B	J - J	G - F
6.5	I - I	B - B	J - J	G - F
7.8	I - I	B - B	J - J	G - F
9.8	I - I	B - B	J - J	G - F

Table showing standard flange and thread combinations available in stock

Body (threads/flanges)													
	A		B		C		D		E		F		G
	H		I		J	Closed Body		Z					

intermediate pump - series XV

X11-1

SHAPED INTERMEDIATE PUMP
SHAPED FEMALE Ø25,4 FLANGE

X 1 I 25 74 S I I D

Series	X	series XV
Group	1	group 1
Category	I	intermediate pump
Displacement	25	3.8
Flange	74	Ø25.4 body-shaped female right rotation 1P+0P
Shaft	S	SCI01 - Intermediate
Body	IN	inlet - Ø30 Ø12 M6
	OUT	outlet - Ø30 Ø12 M6
Cover	D	Ø25,5 body-shaped female cover for left multiple pump element

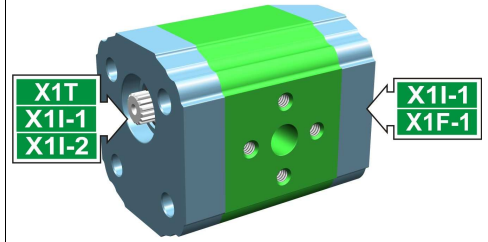

X1102

Technical data table

TYPE	Displacement cm3/rev	Max. Pressure		CODE	
		P1 bar	P3 bar	Left rotation	Right rotation
X11-1/0.9	0,91	240	280	X 1 I 16 73 S I I A	X 1 I 16 74 S I I A
X11-1/1.2	1,17	250	290	X 1 I 17 73 S I I A	X 1 I 17 74 S I I A
X11-1/1.7	1,56	250	290	X 1 I 18 73 S I I A	X 1 I 18 74 S I I A
X11-1/2.2	2,08	250	290	X 1 I 20 73 S I I A	X 1 I 20 74 S I I A
X11-1/2.6	2,60	250	300	X 1 I 21 73 S I I A	X 1 I 21 74 S I I A
X11-1/3.2	3,12	250	300	X 1 I 23 73 S I I A	X 1 I 23 74 S I I A
X11-1/3.8	3,64	250	300	X 1 I 25 73 S I I A	X 1 I 25 74 S I I A
X11-1/4.3	4,16	250	300	X 1 I 27 73 S I I A	X 1 I 27 74 S I I A
X11-1/4.9	4,94	250	300	X 1 I 29 73 S I I A	X 1 I 29 74 S I I A
X11-1/5.9	5,85	250	300	X 1 I 31 73 S I I A	X 1 I 31 74 S I I A
X11-1/6.5	6,50	250	300	X 1 I 32 73 S I I A	X 1 I 32 74 S I I A
X11-1/7.8	7,54	220	260	X 1 I 34 73 S I I A	X 1 I 34 74 S I I A
X11-1/9.8	9,88	190	230	X 1 I 36 73 S I I A	X 1 I 36 74 S I I A

P1) Max. working pressure - P3) Max. peak pressure

For heavy-duty applications, it is recommended to check the admissible torque of the shaft

Dimensions table

TYPE	Weight kg	A	B	D	E	F	D	E	F
		mm	mm	IN			OUT		
X11-1/0.9	0,950	74,5	37,3	Ø12	30	M6x1	Ø12	30	M6x1
X11-1/1.2	0,970	75,5	37,8	Ø12	30	M6x1	Ø12	30	M6x1
X11-1/1.7	1,010	77,0	38,5	Ø12	30	M6x1	Ø12	30	M6x1
X11-1/2.2	1,030	79,0	39,5	Ø12	30	M6x1	Ø12	30	M6x1
X11-1/2.6	1,060	81,0	40,5	Ø12	30	M6x1	Ø12	30	M6x1
X11-1/3.2	1,090	83,0	41,5	Ø12	30	M6x1	Ø12	30	M6x1
X11-1/3.8	1,120	85,0	42,5	Ø12	30	M6x1	Ø12	30	M6x1
X11-1/4.3	1,170	87,0	43,5	Ø12	30	M6x1	Ø12	30	M6x1
X11-1/4.9	1,200	90,0	45,0	Ø12	30	M6x1	Ø12	30	M6x1
X11-1/5.9	1,260	93,5	46,8	Ø12	30	M6x1	Ø12	30	M6x1
X11-1/6.5	1,300	96,0	48,0	Ø12	30	M6x1	Ø12	30	M6x1
X11-1/7.8	1,360	100,0	50,0	Ø12	30	M6x1	Ø12	30	M6x1
X11-1/9.8	1,500	109,0	54,5	Ø12	30	M6x1	Ø12	30	M6x1

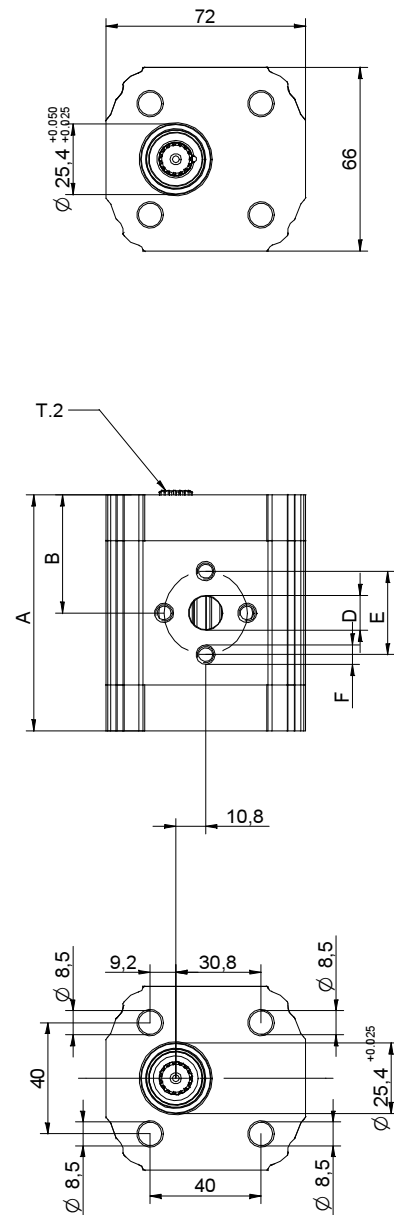

29/04/08 X112574SIIID.dft

T.2 = 42.8 [Nm] - admissible shaft torque (N.B. When choosing a shaft, always check the admissible torque).

Table of variations

X11-1

Shaped female $\varnothing 25,4$ FLANGE

Shaped female $\varnothing 25,4$ FLANGE		Shaft		Cover		
Left rotation	Right rotation			Left rotation	Right rotation	
		SCI01 - Splined $T.2 = 42.8$ [Nm] $m=0,75$ $Z=15$ 				A
						D

Displacement	
TYPE	CODE
X11-1/0.9	16
X11-1/1.2	17
X11-1/1.7	18
X11-1/2.2	20
X11-1/2.6	21
X11-1/3.2	23
X11-1/3.8	25
X11-1/4.3	27
X11-1/4.9	29
X11-1/5.9	31
X11-1/6.5	32
X11-1/7.8	34
X11-1/9.8	36

Standard bodies				
Displacement cm3/rev	Standard threads			
	0.9	I - I	B - B	J - J
1.2	I - I	B - B	J - J	G - F
1.7	I - I	B - B	J - J	G - F
2.2	I - I	B - B	J - J	G - F
2.6	I - I	B - B	J - J	G - F
3.2	I - I	B - B	J - J	G - F
3.8	I - I	B - B	J - J	G - F
4.3	I - I	B - B	J - J	G - F
4.9	I - I	B - B	J - J	G - F
5.9	I - I	B - B	J - J	G - F
6.5	I - I	B - B	J - J	G - F
7.8	I - I	B - B	J - J	G - F
9.8	I - I	B - B	J - J	G - F

Table showing standard flange and thread combinations available in stock

Body (threads/flanges)													
	A		B		C		D		E		F		G
	H		I		J	Closed Body	Z						

intermediate pump - series XV

X11-2

INTERMEDIATE PUMP TO BE COUPLED WITH XV2
FEMALE Ø36,5 FLANGE

X 1 I 25 82 S I I A

Series	X	series XV
Group	1	group 1
Category	I	intermediate pump
Displacement	25	3.8
Flange	82	Ø36.5 female right rotation 2P+1P, 3P+1P
Shaft	S	SCI01 - Intermediate
Body	IN	inlet - Ø30 Ø12 M6
	OUT	outlet - Ø30 Ø12 M6
Cover	A	Ø25,5 female cover for left multiple pump element

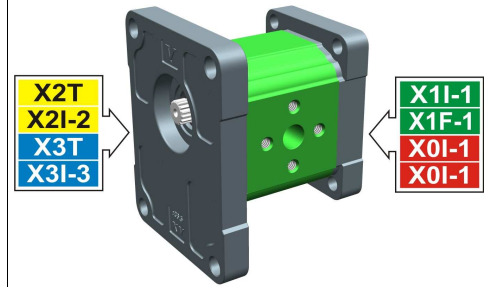

XI103

Technical data table

TYPE	Displacement cm3/rev	Max. Pressure		CODE																	
		P1 bar	P3 bar	Left rotation			Right rotation														
X11-2/0.9	0,91	240	280	X	1	I	16	81	S	I	I	A	X	1	I	16	82	S	I	I	A
X11-2/1.2	1,17	250	290	X	1	I	17	81	S	I	I	A	X	1	I	17	82	S	I	I	A
X11-2/1.7	1,56	250	290	X	1	I	18	81	S	I	I	A	X	1	I	18	82	S	I	I	A
X11-2/2.2	2,08	250	290	X	1	I	20	81	S	I	I	A	X	1	I	20	82	S	I	I	A
X11-2/2.6	2,60	250	300	X	1	I	21	81	S	I	I	A	X	1	I	21	82	S	I	I	A
X11-2/3.2	3,12	250	300	X	1	I	23	81	S	I	I	A	X	1	I	23	82	S	I	I	A
X11-2/3.8	3,64	250	300	X	1	I	25	81	S	I	I	A	X	1	I	25	82	S	I	I	A
X11-2/4.3	4,16	250	300	X	1	I	27	81	S	I	I	A	X	1	I	27	82	S	I	I	A
X11-2/4.9	4,94	250	300	X	1	I	29	81	S	I	I	A	X	1	I	29	82	S	I	I	A
X11-2/5.9	5,85	250	300	X	1	I	31	81	S	I	I	A	X	1	I	31	82	S	I	I	A
X11-2/6.5	6,50	250	300	X	1	I	32	81	S	I	I	A	X	1	I	32	82	S	I	I	A
X11-2/7.8	7,54	220	260	X	1	I	34	81	S	I	I	A	X	1	I	34	82	S	I	I	A
X11-2/9.8	9,88	190	230	X	1	I	36	81	S	I	I	A	X	1	I	36	82	S	I	I	A

P1) Max. working pressure - P3) Max. peak pressure

For heavy-duty applications, it is recommended to check the admissible torque of the shaft

Dimensions table

TYPE	Weight kg	A	B	D	E	F	D	E	F
		mm	mm	IN			OUT		
X11-2/0.9	0,950	78,0	40,8	Ø12	30	M6x1	Ø12	30	M6x1
X11-2/1.2	0,970	79,0	41,3	Ø12	30	M6x1	Ø12	30	M6x1
X11-2/1.7	1,010	80,5	42,0	Ø12	30	M6x1	Ø12	30	M6x1
X11-2/2.2	1,030	82,5	43,0	Ø12	30	M6x1	Ø12	30	M6x1
X11-2/2.6	1,060	84,5	44,0	Ø12	30	M6x1	Ø12	30	M6x1
X11-2/3.2	1,090	86,5	45,0	Ø12	30	M6x1	Ø12	30	M6x1
X11-2/3.8	1,120	88,5	46,0	Ø12	30	M6x1	Ø12	30	M6x1
X11-2/4.3	1,170	90,5	47,0	Ø12	30	M6x1	Ø12	30	M6x1
X11-2/4.9	1,200	93,5	48,5	Ø12	30	M6x1	Ø12	30	M6x1
X11-2/5.9	1,260	97,0	50,3	Ø12	30	M6x1	Ø12	30	M6x1
X11-2/6.5	1,300	99,5	51,5	Ø12	30	M6x1	Ø12	30	M6x1
X11-2/7.8	1,360	103,5	53,5	Ø12	30	M6x1	Ø12	30	M6x1
X11-2/9.8	1,500	112,5	58,0	Ø12	30	M6x1	Ø12	30	M6x1

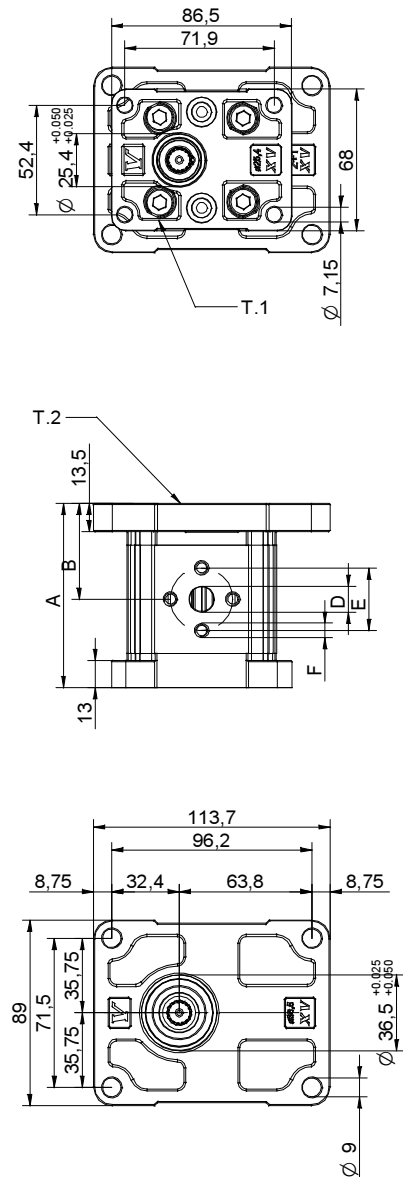

0104/08 XI1258231A.dft

T.1 = 24.5÷29.4 [Nm] - screw tightening torque M8

T.2 = 42.8 [Nm] - admissible shaft torque (N.B. When choosing a shaft, always check the admissible torque).

Table of variations

X11-2

Female $\varnothing 36.5$ FLANGE

Female $\varnothing 36.5$ FLANGE		Shaft		Cover		
Left rotation	Right rotation			Left rotation	Right rotation	
		SCI01 - Splined $T.2 = 42.8$ [Nm] $m=0,75$ $Z=15$ 				A
						D

Displacement	
TYPE	CODE
X11-2/0.9	16
X11-2/1.2	17
X11-2/1.7	18
X11-2/2.2	20
X11-2/2.6	21
X11-2/3.2	23
X11-2/3.8	25
X11-2/4.3	27
X11-2/4.9	29
X11-2/5.9	31
X11-2/6.5	32
X11-2/7.8	34
X11-2/9.8	36

Standard bodies				
Displacement cm3/rev	Standard threads			
	0.9	I - I	B - B	J - J
1.2	I - I	B - B	J - J	G - F
1.7	I - I	B - B	J - J	G - F
2.2	I - I	B - B	J - J	G - F
2.6	I - I	B - B	J - J	G - F
3.2	I - I	B - B	J - J	G - F
3.8	I - I	B - B	J - J	G - F
4.3	I - I	B - B	J - J	G - F
4.9	I - I	B - B	J - J	G - F
5.9	I - I	B - B	J - J	G - F
6.5	I - I	B - B	J - J	G - F
7.8	I - I	B - B	J - J	G - F
9.8	I - I	B - B	J - J	G - F

Table showing standard flange and thread combinations available in stock

Body (threads/flanges)													
	A		B		C		D		E		F		G
	H		I		J	Closed Body	Z						

final pump - series XV

STANDARD FINAL PUMP
FEMALE Ø25,4 FLANGE

X1F-1

X 1 F 25 72 T I I A

Series	X	series XV
Group	1	group 1
Category	F	final pump
Displacement	25	3.8
Flange	72	Ø25.4 female right rotation 1P+1P
Shaft	T	SCF01 - Final
Body	IN	inlet - Ø30 Ø12 M6
	OUT	outlet - Ø30 Ø12 M6
Cover	A	standard

X1T
X1-1
X1-2

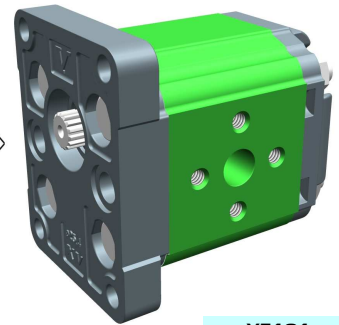

XF101

Technical data table

TYPE	Displacement cm3/rev	Max. Pressure		CODE																	
		P1 bar	P3 bar	Left rotation			Right rotation														
X1F-1/0.9	0,91	240	280	X	1	F	16	71	T	I	I	A	X	1	F	16	72	T	I	I	A
X1F-1/1.2	1,17	250	290	X	1	F	17	71	T	I	I	A	X	1	F	17	72	T	I	I	A
X1F-1/1.7	1,56	250	290	X	1	F	18	71	T	I	I	A	X	1	F	18	72	T	I	I	A
X1F-1/2.2	2,08	250	290	X	1	F	20	71	T	I	I	A	X	1	F	20	72	T	I	I	A
X1F-1/2.6	2,60	250	300	X	1	F	21	71	T	I	I	A	X	1	F	21	72	T	I	I	A
X1F-1/3.2	3,12	250	300	X	1	F	23	71	T	I	I	A	X	1	F	23	72	T	I	I	A
X1F-1/3.8	3,64	250	300	X	1	F	25	71	T	I	I	A	X	1	F	25	72	T	I	I	A
X1F-1/4.3	4,16	250	300	X	1	F	27	71	T	I	I	A	X	1	F	27	72	T	I	I	A
X1F-1/4.9	4,94	250	300	X	1	F	29	71	T	I	I	A	X	1	F	29	72	T	I	I	A
X1F-1/5.9	5,85	250	300	X	1	F	31	71	T	I	I	A	X	1	F	31	72	T	I	I	A
X1F-1/6.5	6,50	250	300	X	1	F	32	71	T	I	I	A	X	1	F	32	72	T	I	I	A
X1F-1/7.8	7,54	220	260	X	1	F	34	71	T	I	I	A	X	1	F	34	72	T	I	I	A
X1F-1/9.8	9,88	190	230	X	1	F	36	71	T	I	I	A	X	1	F	36	72	T	I	I	A

P1) Max. working pressure - P3) Max. peak pressure

For heavy-duty applications, it is recommended to check the admissible torque of the shaft

Dimensions table

TYPE	Weight kg	A	B	D	E	F	D	E	F
		mm	mm	IN			OUT		
X1F-1/0.9	0,950	78,0	37,3	Ø12	30	M6x1	Ø12	30	M6x1
X1F-1/1.2	0,970	79,0	37,8	Ø12	30	M6x1	Ø12	30	M6x1
X1F-1/1.7	1,010	80,5	38,5	Ø12	30	M6x1	Ø12	30	M6x1
X1F-1/2.2	1,030	82,5	39,5	Ø12	30	M6x1	Ø12	30	M6x1
X1F-1/2.6	1,060	84,5	40,5	Ø12	30	M6x1	Ø12	30	M6x1
X1F-1/3.2	1,090	86,5	41,5	Ø12	30	M6x1	Ø12	30	M6x1
X1F-1/3.8	1,120	88,5	42,5	Ø12	30	M6x1	Ø12	30	M6x1
X1F-1/4.3	1,170	90,5	43,5	Ø12	30	M6x1	Ø12	30	M6x1
X1F-1/4.9	1,200	93,5	45,0	Ø12	30	M6x1	Ø12	30	M6x1
X1F-1/5.9	1,260	97,0	46,8	Ø12	30	M6x1	Ø12	30	M6x1
X1F-1/6.5	1,300	99,5	48,0	Ø12	30	M6x1	Ø12	30	M6x1
X1F-1/7.8	1,360	103,5	50,0	Ø12	30	M6x1	Ø12	30	M6x1
X1F-1/9.8	1,500	112,5	54,5	Ø12	30	M6x1	Ø12	30	M6x1

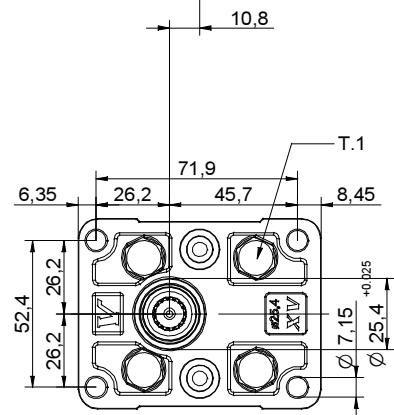
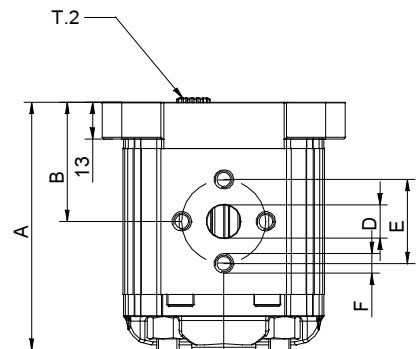
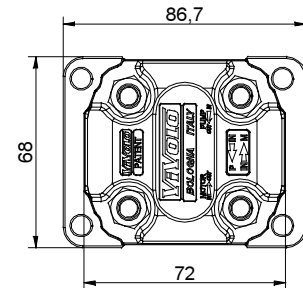

0104/08 XF25Z7IIA.dft

T.1 = 24.5÷29.4 [Nm] - screw tightening torque M8

T.2 = 42.8 [Nm] - admissible shaft torque (N.B. When choosing a shaft, always check the admissible torque).

Table of variations

X1F-1

Standard female $\phi 25,4$ FLANGE

Standard female $\phi 25,4$ FLANGE		Shaft		Cover	
Left rotation	Right rotation			Left rotation	Right rotation
		SCF01 - Splined $T.2 = 42.8$ [Nm] $m=0,75$ $Z=15$ 			
	71		72		

Displacement	
TYPE	CODE
X1F-1/0.9	16
X1F-1/1.2	17
X1F-1/1.7	18
X1F-1/2.2	20
X1F-1/2.6	21
X1F-1/3.2	23
X1F-1/3.8	25
X1F-1/4.3	27
X1F-1/4.9	29
X1F-1/5.9	31
X1F-1/6.5	32
X1F-1/7.8	34
X1F-1/9.8	36

Standard bodies							
Displacement cm3/rev	Standard threads						
	0.9	I - I	B - B	J - J	B - Z	Z - Z	G - F
1.2	I - I	B - B	J - J	B - Z	Z - Z	G - F	
1.7	I - I	B - B	J - J	B - Z	Z - Z	G - F	
2.2	I - I	B - B	J - J	B - Z	Z - Z	G - F	
2.6	I - I	B - B	J - J	B - Z	Z - Z	G - F	
3.2	I - I	B - B	J - J	B - Z	Z - Z	G - F	
3.8	I - I	B - B	J - J	B - Z	Z - Z	G - F	
4.3	I - I	B - B	J - J	B - Z	Z - Z	G - F	
4.9	I - I	B - B	J - J	B - Z	Z - Z	G - F	
5.9	I - I	B - B	J - J	B - Z	Z - Z	G - F	
6.5	I - I	B - B	J - J	B - Z	Z - Z	G - F	
7.8	I - I	B - B	J - J	B - Z	Z - Z	G - F	
9.8	I - I	B - B	J - J	B - Z	Z - Z	G - F	

Table showing standard flange and thread combinations available in stock

		A
		B
		C
		D
		E
		F
		G
		H
		I
		J
		K
		L
		M

Body (threads/flanges)													
	A		B		C		D		E		F		G
	H		I		J	Closed Body		Z					

final pump - series XV

X1F-1

SHAPED FINAL PUMP
SHAPED FEMALE Ø25,4 FLANGE

X 1 F 25 74 T I I A

Series	X	series XV
Group	1	group 1
Category	F	final pump
Displacement	25	3.8
Flange	74	Ø25.4 body-shaped female right rotation 1P+0P
Shaft	T	SCF01 - Final
Body	IN	inlet - Ø30 Ø12 M6
	OUT	outlet - Ø30 Ø12 M6
Cover	A	standard

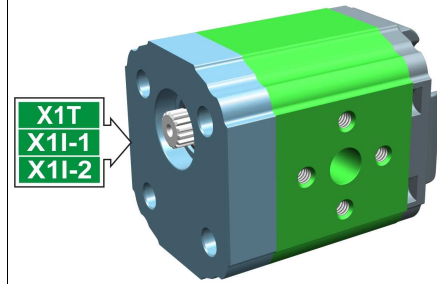

XF102

Technical data table

TYPE	Displacement cm3/rev	Max. Pressure		CODE																	
		P1 bar	P3 bar	Left rotation			Right rotation														
X1F-1/0.9	0,91	240	280	X	1	F	16	73	T	I	I	A	X	1	F	16	74	T	I	I	A
X1F-1/1.2	1,17	250	290	X	1	F	17	73	T	I	I	A	X	1	F	17	74	T	I	I	A
X1F-1/1.7	1,56	250	290	X	1	F	18	73	T	I	I	A	X	1	F	18	74	T	I	I	A
X1F-1/2.2	2,08	250	290	X	1	F	20	73	T	I	I	A	X	1	F	20	74	T	I	I	A
X1F-1/2.6	2,60	250	300	X	1	F	21	73	T	I	I	A	X	1	F	21	74	T	I	I	A
X1F-1/3.2	3,12	250	300	X	1	F	23	73	T	I	I	A	X	1	F	23	74	T	I	I	A
X1F-1/3.8	3,64	250	300	X	1	F	25	73	T	I	I	A	X	1	F	25	74	T	I	I	A
X1F-1/4.3	4,16	250	300	X	1	F	27	73	T	I	I	A	X	1	F	27	74	T	I	I	A
X1F-1/4.9	4,94	250	300	X	1	F	29	73	T	I	I	A	X	1	F	29	74	T	I	I	A
X1F-1/5.9	5,85	250	300	X	1	F	31	73	T	I	I	A	X	1	F	31	74	T	I	I	A
X1F-1/6.5	6,50	250	300	X	1	F	32	73	T	I	I	A	X	1	F	32	74	T	I	I	A
X1F-1/7.8	7,54	220	260	X	1	F	34	73	T	I	I	A	X	1	F	34	74	T	I	I	A
X1F-1/9.8	9,88	190	230	X	1	F	36	73	T	I	I	A	X	1	F	36	74	T	I	I	A

P1) Max. working pressure - P3) Max. peak pressure

For heavy-duty applications, it is recommended to check the admissible torque of the shaft

Dimensions table

TYPE	Weight kg	A	B	D	E	F	D	E	F
		mm	mm	IN			OUT		
X1F-1/0.9	0,950	78,0	37,3	Ø12	30	M6x1	Ø12	30	M6x1
X1F-1/1.2	0,970	79,0	37,8	Ø12	30	M6x1	Ø12	30	M6x1
X1F-1/1.7	1,010	80,5	38,5	Ø12	30	M6x1	Ø12	30	M6x1
X1F-1/2.2	1,030	82,5	39,5	Ø12	30	M6x1	Ø12	30	M6x1
X1F-1/2.6	1,060	84,5	40,5	Ø12	30	M6x1	Ø12	30	M6x1
X1F-1/3.2	1,090	86,5	41,5	Ø12	30	M6x1	Ø12	30	M6x1
X1F-1/3.8	1,120	88,5	42,5	Ø12	30	M6x1	Ø12	30	M6x1
X1F-1/4.3	1,170	90,5	43,5	Ø12	30	M6x1	Ø12	30	M6x1
X1F-1/4.9	1,200	93,5	45,0	Ø12	30	M6x1	Ø12	30	M6x1
X1F-1/5.9	1,260	97,0	46,8	Ø12	30	M6x1	Ø12	30	M6x1
X1F-1/6.5	1,300	99,5	48,0	Ø12	30	M6x1	Ø12	30	M6x1
X1F-1/7.8	1,360	103,5	50,0	Ø12	30	M6x1	Ø12	30	M6x1
X1F-1/9.8	1,500	112,5	54,5	Ø12	30	M6x1	Ø12	30	M6x1

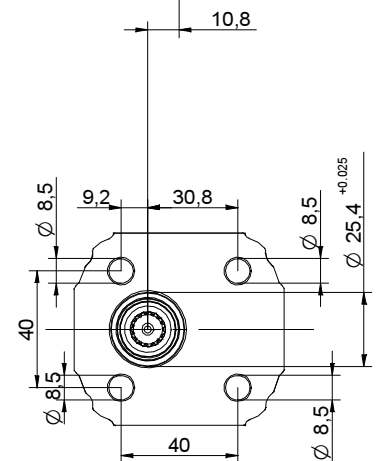
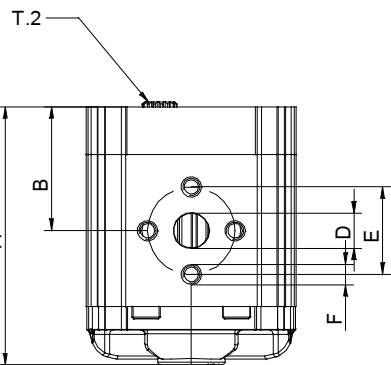
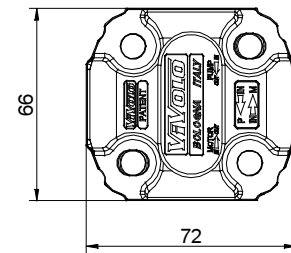

29/04/08 XF2574TIIA.dft



T.2 = 42.8 [Nm] - admissible shaft torque (N.B. When choosing a shaft, always check the admissible torque).

Table of variations

X1F-1

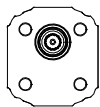
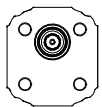
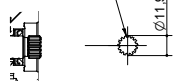
Shaped female $\varnothing 25,4$ FLANGE

Shaped female $\varnothing 25,4$ FLANGE		Shaft	
Left rotation	Right rotation		
		SCF01 - Splined $T.2 = 42.8$ [Nm] $m=0,75$ $Z=15$ 	
73	74	T	

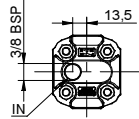
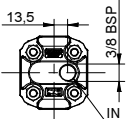
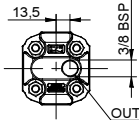
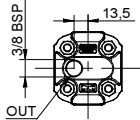
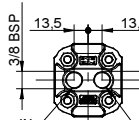
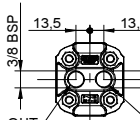
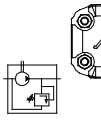
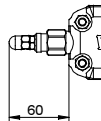
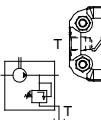
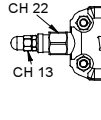
Cover		
Left rotation	Right rotation	
		A
		B
		C
		D
		N
Internal drainage		
		O
External drainage		

Displacement	
TYPE	CODE
X1F-1/0.9	16
X1F-1/1.2	17
X1F-1/1.7	18
X1F-1/2.2	20
X1F-1/2.6	21
X1F-1/3.2	23
X1F-1/3.8	25
X1F-1/4.3	27
X1F-1/4.9	29
X1F-1/5.9	31
X1F-1/6.5	32
X1F-1/7.8	34
X1F-1/9.8	36

Standard bodies							
Displacement cm3/rev	Standard threads						
	0.9	I - I	B - B	J - J	B - Z	Z - Z	G - F
1.2	I - I	B - B	J - J	B - Z	Z - Z	G - F	
1.7	I - I	B - B	J - J	B - Z	Z - Z	G - F	
2.2	I - I	B - B	J - J	B - Z	Z - Z	G - F	
2.6	I - I	B - B	J - J	B - Z	Z - Z	G - F	
3.2	I - I	B - B	J - J	B - Z	Z - Z	G - F	
3.8	I - I	B - B	J - J	B - Z	Z - Z	G - F	
4.3	I - I	B - B	J - J	B - Z	Z - Z	G - F	
4.9	I - I	B - B	J - J	B - Z	Z - Z	G - F	
5.9	I - I	B - B	J - J	B - Z	Z - Z	G - F	
6.5	I - I	B - B	J - J	B - Z	Z - Z	G - F	
7.8	I - I	B - B	J - J	B - Z	Z - Z	G - F	
9.8	I - I	B - B	J - J	B - Z	Z - Z	G - F	

Table showing standard flange and thread combinations available in stock

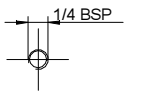
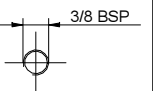
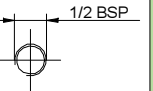
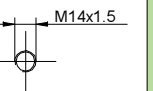
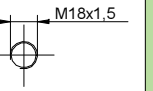
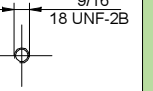
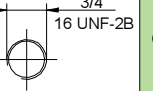
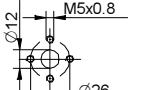
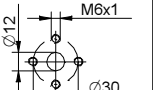
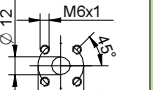
Body (threads/flanges)													
	A		B		C		D		E		F		G
	H		I		J	Z	Closed Body						

final pump - series XV

FINAL PUMP TO BE COUPLED WITH XV2
FEMALE Ø36,5 FLANGE

X1F-2

X 1 F 25 82 T I I A

Series	X	series XV
Group	1	group 1
Category	F	final pump
Displacement	25	3.8
Flange	82	Ø36.5 female right rotation 2P+1P, 3P+1P
Shaft	T	SCF01 - Final
Body	IN	inlet - Ø30 Ø12 M6
	OUT	outlet - Ø30 Ø12 M6
Cover	A	standard

X2T
X2I-2
X3T
X3I-3

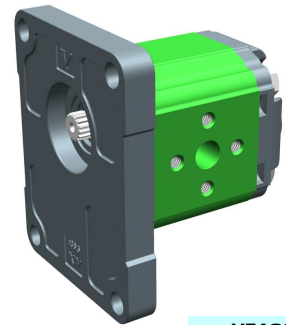

XF103

Technical data table

TYPE	Displacement cm3/rev	Max. Pressure		CODE																	
		P1 bar	P3 bar	Left rotation			Right rotation														
X1F-2/0.9	0,91	240	280	X	1	F	16	81	T	I	I	A	X	1	F	16	82	T	I	I	A
X1F-2/1.2	1,17	250	290	X	1	F	17	81	T	I	I	A	X	1	F	17	82	T	I	I	A
X1F-2/1.7	1,56	250	290	X	1	F	18	81	T	I	I	A	X	1	F	18	82	T	I	I	A
X1F-2/2.2	2,08	250	290	X	1	F	20	81	T	I	I	A	X	1	F	20	82	T	I	I	A
X1F-2/2.6	2,60	250	300	X	1	F	21	81	T	I	I	A	X	1	F	21	82	T	I	I	A
X1F-2/3.2	3,12	250	300	X	1	F	23	81	T	I	I	A	X	1	F	23	82	T	I	I	A
X1F-2/3.8	3,64	250	300	X	1	F	25	81	T	I	I	A	X	1	F	25	82	T	I	I	A
X1F-2/4.3	4,16	250	300	X	1	F	27	81	T	I	I	A	X	1	F	27	82	T	I	I	A
X1F-2/4.9	4,94	250	300	X	1	F	29	81	T	I	I	A	X	1	F	29	82	T	I	I	A
X1F-2/5.9	5,85	250	300	X	1	F	31	81	T	I	I	A	X	1	F	31	82	T	I	I	A
X1F-2/6.5	6,50	250	300	X	1	F	32	81	T	I	I	A	X	1	F	32	82	T	I	I	A
X1F-2/7.8	7,54	220	260	X	1	F	34	81	T	I	I	A	X	1	F	34	82	T	I	I	A
X1F-2/9.8	9,88	190	230	X	1	F	36	81	T	I	I	A	X	1	F	36	82	T	I	I	A

P1) Max. working pressure - P3) Max. peak pressure

For heavy-duty applications, it is recommended to check the admissible torque of the shaft

Dimensions table

TYPE	Weight kg	A	B	D	E	F	D	E	F
		mm	mm	IN			OUT		
X1F-2/0.9	0,950	81,5	40,8	Ø12	30	M6x1	Ø12	30	M6x1
X1F-2/1.2	0,970	82,5	41,3	Ø12	30	M6x1	Ø12	30	M6x1
X1F-2/1.7	1,010	84,0	42,0	Ø12	30	M6x1	Ø12	30	M6x1
X1F-2/2.2	1,030	86,0	43,0	Ø12	30	M6x1	Ø12	30	M6x1
X1F-2/2.6	1,060	88,0	44,0	Ø12	30	M6x1	Ø12	30	M6x1
X1F-2/3.2	1,090	90,0	45,0	Ø12	30	M6x1	Ø12	30	M6x1
X1F-2/3.8	1,120	92,0	46,0	Ø12	30	M6x1	Ø12	30	M6x1
X1F-2/4.3	1,170	94,0	47,0	Ø12	30	M6x1	Ø12	30	M6x1
X1F-2/4.9	1,200	97,0	48,5	Ø12	30	M6x1	Ø12	30	M6x1
X1F-2/5.9	1,260	100,5	50,3	Ø12	30	M6x1	Ø12	30	M6x1
X1F-2/6.5	1,300	103,0	51,5	Ø12	30	M6x1	Ø12	30	M6x1
X1F-2/7.8	1,360	107,0	53,5	Ø12	30	M6x1	Ø12	30	M6x1
X1F-2/9.8	1,500	116,0	58,0	Ø12	30	M6x1	Ø12	30	M6x1

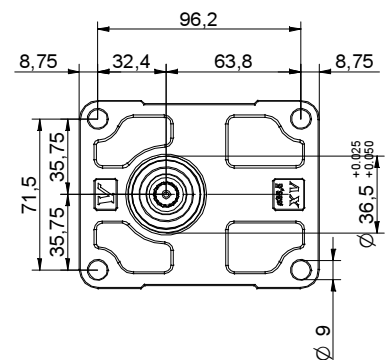
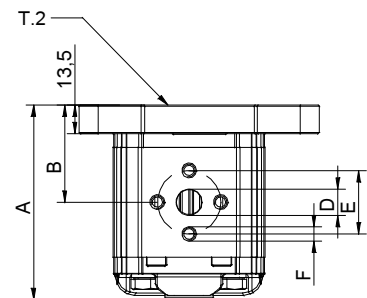
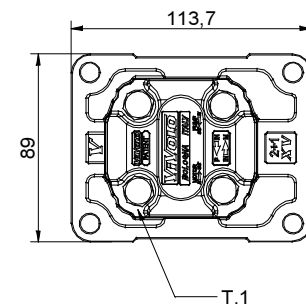

01/04/08 XF2582TIIA.dft

T.1 = 24.5÷29.4 [Nm] - screw tightening torque M8

T.2 = 42.8 [Nm] - admissible shaft torque (N.B. When choosing a shaft, always check the admissible torque).

Table of variations

X1F-2

Female $\varnothing 36.5$ FLANGE

Female $\varnothing 36.5$ FLANGE		Shaft	
Left rotation	Right rotation		
		SCF01 - Splined T.2 = 42.8 [Nm] m=0,75 Z=15	T
81	82		

Cover		
Left rotation	Right rotation	
		A
		B
		C
		D
		N
		O

Displacement	
TYPE	CODE
X1F-2/0.9	16
X1F-2/1.2	17
X1F-2/1.7	18
X1F-2/2.2	20
X1F-2/2.6	21
X1F-2/3.2	23
X1F-2/3.8	25
X1F-2/4.3	27
X1F-2/4.9	29
X1F-2/5.9	31
X1F-2/6.5	32
X1F-2/7.8	34
X1F-2/9.8	36

Standard bodies							
Displacement cm3/rev	Standard threads						
	0.9	I - I	B - B	J - J	B - Z	Z - Z	G - F
1.2	I - I	B - B	J - J	B - Z	Z - Z	G - F	
1.7	I - I	B - B	J - J	B - Z	Z - Z	G - F	
2.2	I - I	B - B	J - J	B - Z	Z - Z	G - F	
2.6	I - I	B - B	J - J	B - Z	Z - Z	G - F	
3.2	I - I	B - B	J - J	B - Z	Z - Z	G - F	
3.8	I - I	B - B	J - J	B - Z	Z - Z	G - F	
4.3	I - I	B - B	J - J	B - Z	Z - Z	G - F	
4.9	I - I	B - B	J - J	B - Z	Z - Z	G - F	
5.9	I - I	B - B	J - J	B - Z	Z - Z	G - F	
6.5	I - I	B - B	J - J	B - Z	Z - Z	G - F	
7.8	I - I	B - B	J - J	B - Z	Z - Z	G - F	
9.8	I - I	B - B	J - J	B - Z	Z - Z	G - F	

Table showing standard flange and thread combinations available in stock

Body (threads/flanges)													
	A		B		C		D		E		F		G
	H		I		J	Closed Body	Z						

entrainment pump - series XV

EUROPEAN STANDARD DRIVING PUMP
 ø36.5 FLANGE - TAPER SHAFT

X2T

X 2 T 51 02 E P O A

Series	X	series XV
Group	2	group 2
Category	T	entrainment pump
Displacement	51	17
Flange	02	Ø36.5 STANDARD EUROPEAN right rotation
Shaft	E	COP01 - Tapered 1:8 - ø17.4 - M12x1.5 - key thk.4
Body	IN	inlet - Ø40 Ø20 M8
	OUT	outlet - Ø30 Ø13.5 M6
Cover	A	ø36,5 female cover for left multiple pump element

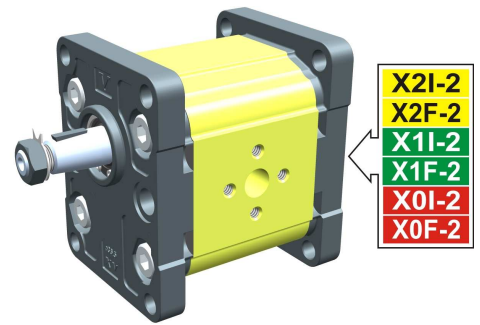

XT201

Technical data table

TYPE	Displacement cm3/rev	Max. Pressure		CODE	
		P1 bar	P3 bar	Left rotation	Right rotation
X2T/04	4,20	260	300	X 2 T 41 01 E O O A	X 2 T 41 02 E O O A
X2T/06	6,00	260	300	X 2 T 43 01 E O O A	X 2 T 43 02 E O O A
X2T/09	8,40	260	300	X 2 T 45 01 E O O A	X 2 T 45 02 E O O A
X2T/11	10,80	260	300	X 2 T 47 01 E O O A	X 2 T 47 02 E O O A
X2T/14	14,40	250	290	X 2 T 49 01 E P O A	X 2 T 49 02 E P O A
X2T/17	16,80	230	270	X 2 T 51 01 E P O A	X 2 T 51 02 E P O A
X2T/19	19,20	210	250	X 2 T 53 01 E P O A	X 2 T 53 02 E P O A
X2T/22	22,80	200	240	X 2 T 55 01 E P O A	X 2 T 55 02 E P O A
X2T/26	26,20	170	210	X 2 T 57 01 E Q P A	X 2 T 57 02 E Q P A
X2T/30	30,00	160	200	X 2 T 59 01 E Q P A	X 2 T 59 02 E Q P A
X2T/34	34,20	150	190	X 2 T 61 01 E Q P A	X 2 T 61 02 E Q P A
X2T/40	39,60	140	180	X 2 T 63 01 E Q P A	X 2 T 63 02 E Q P A

P1) Max. working pressure - P3) Max. peak pressure

For heavy-duty applications, it is recommended to check the admissible torque of the shaft

Dimensions table

TYPE	Weight kg	A	B	D	E	F	D	E	F
		mm	mm	IN			OUT		
X2T/04	2,200	83,4	41,7	ø13,5	30	M6x1	ø13,5	30	M6x1
X2T/06	2,300	86,4	43,2	ø13,5	30	M6x1	ø13,5	30	M6x1
X2T/09	2,400	90,4	45,2	ø13,5	30	M6x1	ø13,5	30	M6x1
X2T/11	2,500	94,4	47,2	ø13,5	30	M6x1	ø13,5	30	M6x1
X2T/14	2,700	100,4	50,2	ø20	40	M8X1,25	ø13,5	30	M6x1
X2T/17	2,800	104,4	52,2	ø20	40	M8X1,25	ø13,5	30	M6x1
X2T/19	2,900	108,4	54,2	ø20	40	M8X1,25	ø13,5	30	M6x1
X2T/22	3,050	114,4	57,2	ø20	40	M8X1,25	ø13,5	30	M6x1
X2T/26	3,150	118,4	59,2	ø23,5	40	M8X1,25	ø20	40	M8X1,25
X2T/30	3,400	126,4	63,2	ø23,5	40	M8X1,25	ø20	40	M8X1,25
X2T/34	3,600	133,4	66,7	ø23,5	40	M8X1,25	ø20	40	M8X1,25
X2T/40	3,800	142,4	71,2	ø23,5	40	M8X1,25	ø20	40	M8X1,25

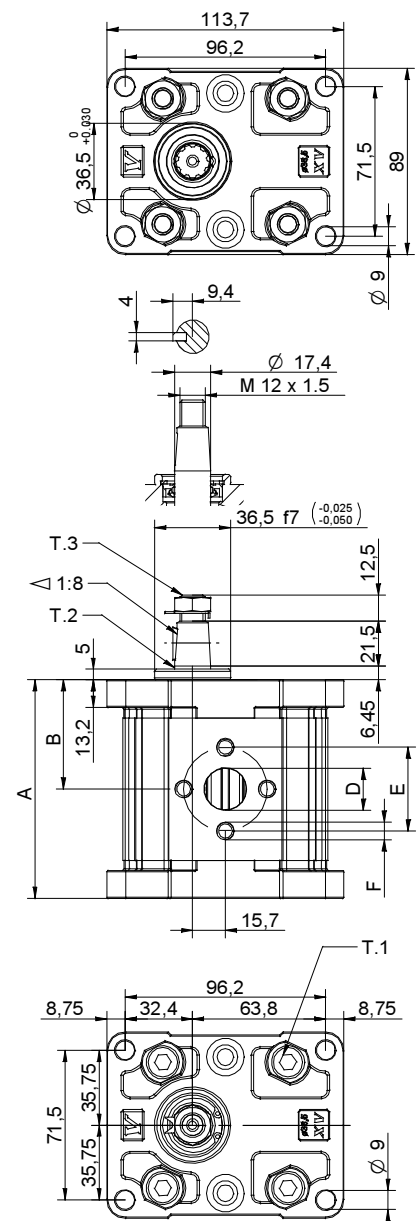

T.1 = 54-58.9 [Nm] - screw tightening torque M10

T.3 = 40 [Nm] - torque wrench setting 19

T.2 = 233.2 [Nm] - admissible shaft torque (N.B. When choosing a shaft, always check the admissible torque).

Table of variations

X2T

ø36.5 FLANGE

ø36.5 FLANGE				Shaft				Cover		
Left rotation		Right rotation						Left rotation	Right rotation	
	01		02	CIP01 - Parallel T.2 = 44.1 [Nm] 	A	CIP02 - Parallel T.2 = 67.5 [Nm] 	B			A
	03		04	COP01 - Tapered T.2 = 233.2 [Nm] 	E	COP02 - Tapered T.2 = 233.2 [Nm] 	F			D
	05		06	SCP02 - Splined T.2 = 86.2 [Nm] m=1.6 Z=9 DIN 5482 - 17x14 	G	SCP03 - Splined T.2 = 86.2 [Nm] m=1.6 Z=9 DIN 5482 - 17x14 	H			
	07		08	SCP04 - Splined T.2 = 67.1 [Nm] SAE J 498 9T 16/32 DP 	I	SCI01 - Splined T.2 = 86.2 [Nm] m=1.6 Z=9 DIN 5482 - 17x14 	L			

Displacement	
TYPE	CODE
X2T/04	41
X2T/06	43
X2T/09	45
X2T/11	47
X2T/14	49
X2T/17	51
X2T/19	53
X2T/22	55
X2T/26	57
X2T/30	59
X2T/34	61
X2T/40	63

Standard bodies						
Displacement cm3/rev	Standard threads					
	4	O - O	S - R	B - B	L - M	Z - Z
6	O - O	S - R	B - B	L - M	Z - Z	
9	O - O	S - R	B - B	L - M	Z - Z	
11	O - O	S - R	B - B	L - M	Z - Z	
14	P - O	S - R	C - B	L - M	Z - Z	
17	P - O	S - R	C - B	L - M	Z - Z	
19	P - O	S - R	C - B	L - M	Z - Z	
22	P - O	S - R	C - B	L - M	Z - Z	
26	Q - P	S - R	D - C	L - M	Z - Z	
30	Q - P	S - S	D - C	L - M	Z - Z	
34	Q - P	S - S	D - C	L - M	Z - Z	
40	Q - P	S - S	D - C	L - M	Z - Z	

Table showing standard flange and thread combinations available in stock

Body (threads/flanges)													
	A		B		C		D		E		F		G
	H		I		L		M		N		O		P
	Q		R		S		T		U		V	Closed Body	Z

entrainment pump - series XV

X2T

"BH" DRIVING PUMP
 ø50 BODY-SHAPED FLANGE - TAPER SHAFT

X 2 T 51 12 F S R D

Series	X	series XV
Group	2	group 2
Category	T	entrainment pump
Displacement	51	17
Flange	12	ø50 BH GERMAN STANDARDIZED right rotation
Shaft	F	COP02 - Tapered 1:5 - ø17.4 - M12x1.5 - key thk.3
Body	IN OUT	inlet - ø40 a 45° ø20 M6 outlet - ø35 a 45° ø15 M6
Cover	D	ø36,5 body-shaped female cover for left multiple pump element

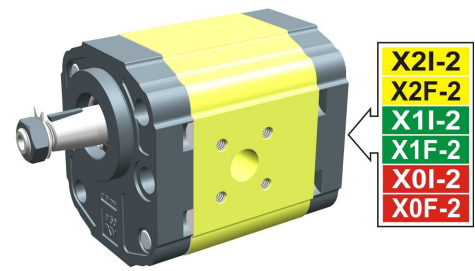

XT210

Technical data table																					
TYPE	Displacement cm3/rev	Max. Pressure		CODE																	
		P1 bar	P3 bar	Left rotation			Right rotation														
X2T/04	4,20	260	300	X	2	T	41	11	F	S	R	D	X	2	T	41	12	F	S	R	D
X2T/06	6,00	260	300	X	2	T	43	11	F	S	R	D	X	2	T	43	12	F	S	R	D
X2T/09	8,40	260	300	X	2	T	45	11	F	S	R	D	X	2	T	45	12	F	S	R	D
X2T/11	10,80	260	300	X	2	T	47	11	F	S	R	D	X	2	T	47	12	F	S	R	D
X2T/14	14,40	250	290	X	2	T	49	11	F	S	R	D	X	2	T	49	12	F	S	R	D
X2T/17	16,80	230	270	X	2	T	51	11	F	S	R	D	X	2	T	51	12	F	S	R	D
X2T/19	19,20	210	250	X	2	T	53	11	F	S	R	D	X	2	T	53	12	F	S	R	D
X2T/22	22,80	200	240	X	2	T	55	11	F	S	R	D	X	2	T	55	12	F	S	R	D
X2T/26	26,20	170	210	X	2	T	57	11	F	S	R	D	X	2	T	57	12	F	S	R	D
X2T/30	30,00	160	200	X	2	T	59	11	F	S	S	D	X	2	T	59	12	F	S	S	D
X2T/34	34,20	150	190	X	2	T	61	11	F	S	S	D	X	2	T	61	12	F	S	S	D
X2T/40	39,60	140	180	X	2	T	63	11	F	S	S	D	X	2	T	63	12	F	S	S	D

P1) Max. working pressure - P3) Max. peak pressure

For heavy-duty applications, it is recommended to check the admissible torque of the shaft

Dimensions table									
TYPE	Weight kg	A	B	D	E	F	D	E	F
		mm	mm	IN			OUT		
X2T/04	2,100	83,4	38,6	ø20	40	M6x1	ø15	35	M6x1
X2T/06	2,200	86,4	38,6	ø20	40	M6x2	ø15	35	M6x1
X2T/09	2,300	90,4	40,6	ø20	40	M6x3	ø15	35	M6x1
X2T/11	2,400	94,4	45,0	ø20	40	M6x4	ø15	35	M6x1
X2T/14	2,600	100,4	45,0	ø20	40	M6x5	ø15	35	M6x1
X2T/17	2,700	104,4	45,0	ø20	40	M6x6	ø15	35	M6x1
X2T/19	2,800	108,4	45,0	ø20	40	M6x7	ø15	35	M6x1
X2T/22	2,950	114,4	52,5	ø20	40	M6x8	ø15	35	M6x1
X2T/26	3,050	118,4	52,5	ø20	40	M6x9	ø15	35	M6x1
X2T/30	3,300	126,4	60,7	ø20	40	M6x10	ø20	40	M6x1
X2T/34	3,500	133,4	60,7	ø20	40	M6x11	ø20	40	M6x1
X2T/40	3,700	142,4	60,7	ø20	40	M6x12	ø20	40	M6x1

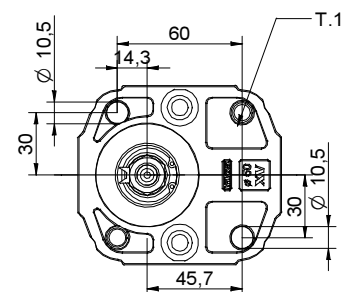
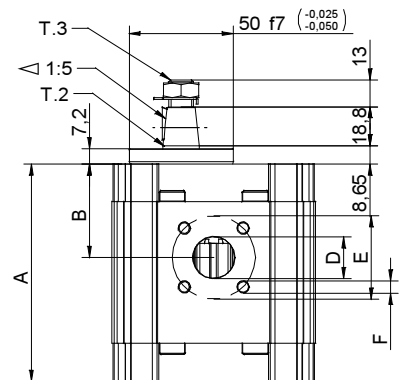
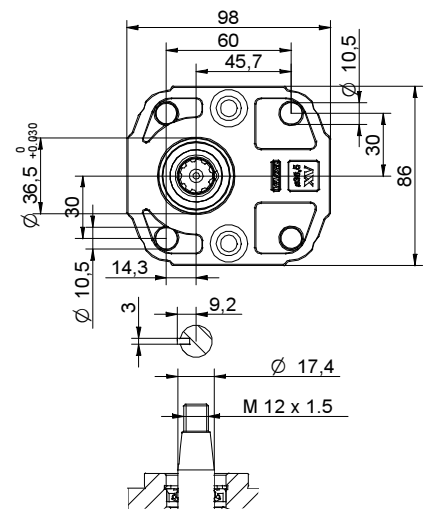

02/04/08 X2T5112E SRD.dft

T.1 = 54±58.9 [Nm] - screw tightening torque M10

T.3 = 40 [Nm] - torque wrench setting 19

T.2 = 233.2 [Nm] - admissible shaft torque (N.B. When choosing a shaft, always check the admissible torque).

Table of variations

X2T

ø50 "BH" Body-Shaped FLANGE

ø50 "BH" Body-Shaped FLANGE				Shaft				Cover		
Left rotation		Right rotation		CIP01 - Parallel T.2 = 44.1 [Nm]		CIP02 - Parallel T.2 = 67.5 [Nm]		Left rotation	Right rotation	
	11		12		A		B			A
	13		14		E		F			D
	15		16	SCP03 - Splined T.2 = 86.2 [Nm]		H				
	17		18							

Displacement	
TYPE	CODE
X2T/04	41
X2T/06	43
X2T/09	45
X2T/11	47
X2T/14	49
X2T/17	51
X2T/19	53
X2T/22	55
X2T/26	57
X2T/30	59
X2T/34	61
X2T/40	63

Standard bodies						
Displacement cm3/rev	Standard threads					
	4	O - O	S - R	B - B	L - M	Z - Z
6	O - O	S - R	B - B	L - M	Z - Z	
9	O - O	S - R	B - B	L - M	Z - Z	
11	O - O	S - R	B - B	L - M	Z - Z	
14	P - O	S - R	C - B	L - M	Z - Z	
17	P - O	S - R	C - B	L - M	Z - Z	
19	P - O	S - R	C - B	L - M	Z - Z	
22	P - O	S - R	C - B	L - M	Z - Z	
26	Q - P	S - R	D - C	L - M	Z - Z	
30	Q - P	S - S	D - C	L - M	Z - Z	
34	Q - P	S - S	D - C	L - M	Z - Z	
40	Q - P	S - S	D - C	L - M	Z - Z	

Table showing standard flange and thread combinations available in stock

Body (threads/flanges)													
	A		B		C		D		E		F		G
	H		I		L		M		N		O		P
	Q		R		S		T		U		V	Closed Body Z	

entrainment pump - series XV

X2T

"HY" DRIVING PUMP
 ø50 BODY-SHAPED FLANGE - TAPER SHAFT

X 2 T 51 22 F S R D

Series	X	series XV
Group	2	group 2
Category	T	entrainment pump
Displacement	51	17
Flange	22	ø50 HY GERMAN STANDARDIZED right rotation
Shaft	F	COP02 - Tapered 1:5 - ø17.4 - M12x1.5 - key thk.3
Body	IN	inlet - Ø40 a 45° Ø20 M6
	OUT	outlet - Ø35 a 45° Ø15 M6
Cover	D	ø36,5 body-shaped female cover for left multiple pump element

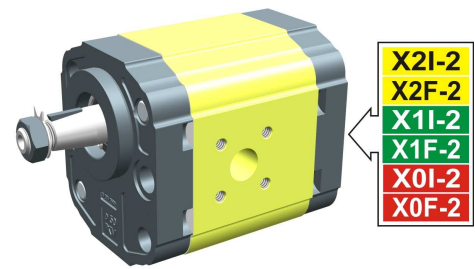

XT213

Technical data table																					
TYPE	Displacement cm3/rev	Max. Pressure		CODE																	
		P1 bar	P3 bar	Left rotation			Right rotation														
X2T/04	4,20	260	300	X	2	T	41	21	F	S	R	D	X	2	T	41	22	F	S	R	D
X2T/06	6,00	260	300	X	2	T	43	21	F	S	R	D	X	2	T	43	22	F	S	R	D
X2T/09	8,40	260	300	X	2	T	45	21	F	S	R	D	X	2	T	45	22	F	S	R	D
X2T/11	10,80	260	300	X	2	T	47	21	F	S	R	D	X	2	T	47	22	F	S	R	D
X2T/14	14,40	250	290	X	2	T	49	21	F	S	R	D	X	2	T	49	22	F	S	R	D
X2T/17	16,80	230	270	X	2	T	51	21	F	S	R	D	X	2	T	51	22	F	S	R	D
X2T/19	19,20	210	250	X	2	T	53	21	F	S	R	D	X	2	T	53	22	F	S	R	D
X2T/22	22,80	200	240	X	2	T	55	21	F	S	R	D	X	2	T	55	22	F	S	R	D
X2T/26	26,20	170	210	X	2	T	57	21	F	S	R	D	X	2	T	57	22	F	S	R	D
X2T/30	30,00	160	200	X	2	T	59	21	F	S	S	D	X	2	T	59	22	F	S	S	D
X2T/34	34,20	150	190	X	2	T	61	21	F	S	S	D	X	2	T	61	22	F	S	S	D
X2T/40	39,60	140	180	X	2	T	63	21	F	S	S	D	X	2	T	63	22	F	S	S	D

P1) Max. working pressure - P3) Max. peak pressure

For heavy-duty applications, it is recommended to check the admissible torque of the shaft

Dimensions table									
TYPE	Weight kg	A	B	D	E	F	D	E	F
		mm	mm	IN			OUT		
X2T/04	2,100	83,4	38,6	ø20	40	M6x1	ø15	35	M6x1
X2T/06	2,200	86,4	38,6	ø20	40	M6x2	ø15	35	M6x1
X2T/09	2,300	90,4	40,6	ø20	40	M6x3	ø15	35	M6x1
X2T/11	2,400	94,4	45,0	ø20	40	M6x4	ø15	35	M6x1
X2T/14	2,600	100,4	45,0	ø20	40	M6x5	ø15	35	M6x1
X2T/17	2,700	104,4	45,0	ø20	40	M6x6	ø15	35	M6x1
X2T/19	2,800	108,4	45,0	ø20	40	M6x7	ø15	35	M6x1
X2T/22	2,950	114,4	52,5	ø20	40	M6x8	ø15	35	M6x1
X2T/26	3,050	118,4	52,5	ø20	40	M6x9	ø15	35	M6x1
X2T/30	3,300	126,4	60,7	ø20	40	M6x10	ø20	40	M6x1
X2T/34	3,500	133,4	60,7	ø20	40	M6x11	ø20	40	M6x1
X2T/40	3,700	142,4	60,7	ø20	40	M6x12	ø20	40	M6x1

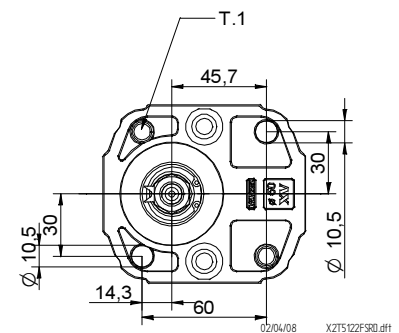
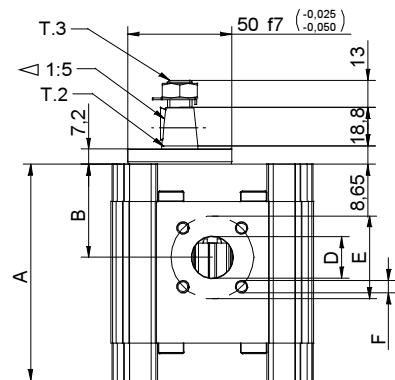
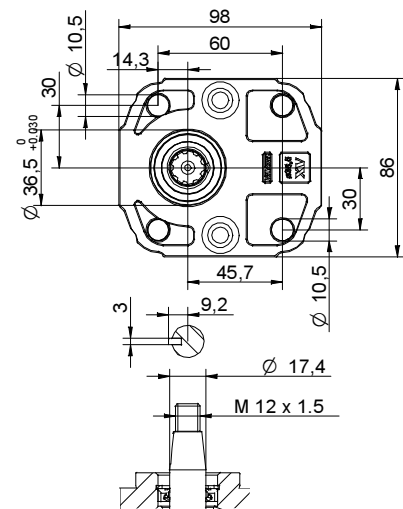

T.1 = 54÷58.9 [Nm] - screw tightening torque M10

T.3 = 40 [Nm] - torque wrench setting 19

T.2 = 233.2 [Nm] - admissible shaft torque (N.B. When choosing a shaft, always check the admissible torque).

Table of variations

X2T

ø50 "HY" Body-Shaped FLANGE

ø50 "HY" Body-Shaped FLANGE				Shaft				Cover		
Left rotation		Right rotation		CIP01 - Parallel T.2 = 44.1 [Nm]		CIP02 - Parallel T.2 = 67.5 [Nm]		Left rotation	Right rotation	
	21		22		A		B			A
	23		24		E		F			D
	25		26	SCP03 - Splined T.2 = 86.2 [Nm]		H				
	27		28							

Displacement	
TYPE	CODE
X2T/04	41
X2T/06	43
X2T/09	45
X2T/11	47
X2T/14	49
X2T/17	51
X2T/19	53
X2T/22	55
X2T/26	57
X2T/30	59
X2T/34	61
X2T/40	63

Standard bodies						
Displacement cm3/rev	Standard threads					
	4	O - O	S - R	B - B	L - M	Z - Z
6	O - O	S - R	B - B	L - M	Z - Z	
9	O - O	S - R	B - B	L - M	Z - Z	
11	O - O	S - R	B - B	L - M	Z - Z	
14	P - O	S - R	C - B	L - M	Z - Z	
17	P - O	S - R	C - B	L - M	Z - Z	
19	P - O	S - R	C - B	L - M	Z - Z	
22	P - O	S - R	C - B	L - M	Z - Z	
26	Q - P	S - R	D - C	L - M	Z - Z	
30	Q - P	S - S	D - C	L - M	Z - Z	
34	Q - P	S - S	D - C	L - M	Z - Z	
40	Q - P	S - S	D - C	L - M	Z - Z	

Table showing standard flange and thread combinations available in stock

Body (threads/flanges)													
	A		B		C		D		E		F		G
	H		I		L		M		N		O		P
	Q		R		S		T		U		V	Closed Body Z	

entrainment pump - series XV

X2T

"BH" GERMAN STANDARD DRIVING PUMP
 ø52 BODY-SHAPED FLANGE - MILLED SHANK

X 2 T 51 32 C S R D

Series	X	series XV
Group	2	group 2
Category	T	entrainment pump
Displacement	51	17
Flange	32	Ø52 GERMAN STANDARDIZED right rotation (with OR)
Shaft	C	CFP01 - Milled shank ø15 - thk.8 ("BH" Standard German)
Body	IN	inlet - Ø40 a 45° Ø20 M6
	OUT	outlet - Ø35 a 45° Ø15 M6
Cover	D	ø36,5 body-shaped female cover for left multiple pump element

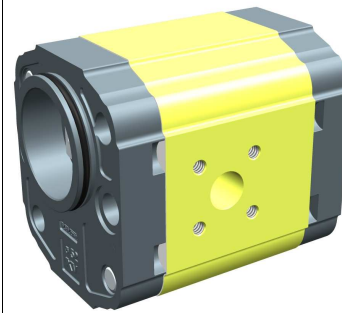

- X2I-2
- X2F-2
- X1I-2
- X1F-2
- X0I-2
- X0F-2

XT216

Technical data table																					
TYPE	Displacement cm3/rev	Max. Pressure		CODE																	
		P1 bar	P3 bar	Left rotation			Right rotation														
X2T/04	4,20	260	300	X	2	T	41	31	C	S	R	D	X	2	T	41	32	C	S	R	D
X2T/06	6,00	260	300	X	2	T	43	31	C	S	R	D	X	2	T	43	32	C	S	R	D
X2T/09	8,40	260	300	X	2	T	45	31	C	S	R	D	X	2	T	45	32	C	S	R	D
X2T/11	10,80	260	300	X	2	T	47	31	C	S	R	D	X	2	T	47	32	C	S	R	D
X2T/14	14,40	250	290	X	2	T	49	31	C	S	R	D	X	2	T	49	32	C	S	R	D
X2T/17	16,80	230	270	X	2	T	51	31	C	S	R	D	X	2	T	51	32	C	S	R	D
X2T/19	19,20	210	250	X	2	T	53	31	C	S	R	D	X	2	T	53	32	C	S	R	D
X2T/22	22,80	200	240	X	2	T	55	31	C	S	R	D	X	2	T	55	32	C	S	R	D
X2T/26	26,20	170	210	X	2	T	57	31	C	S	R	D	X	2	T	57	32	C	S	R	D
X2T/30	30,00	160	200	X	2	T	59	31	C	S	S	D	X	2	T	59	32	C	S	S	D
X2T/34	34,20	150	190	X	2	T	61	31	C	S	S	D	X	2	T	61	32	C	S	S	D
X2T/40	39,60	140	180	X	2	T	63	31	C	S	S	D	X	2	T	63	32	C	S	S	D

P1) Max. working pressure - P3) Max. peak pressure

For heavy-duty applications, it is recommended to check the admissible torque of the shaft

Dimensions table									
TYPE	Weight kg	A mm	B mm	D mm	E mm	IN		OUT	
						F	D	E	F
X2T/04	2,100	83,4	38,6	ø20	40	M6x1	ø15	35	M6x1
X2T/06	2,200	86,4	38,6	ø20	40	M6x2	ø15	35	M6x1
X2T/09	2,300	90,4	40,6	ø20	40	M6x3	ø15	35	M6x1
X2T/11	2,400	94,4	45,0	ø20	40	M6x4	ø15	35	M6x1
X2T/14	2,600	100,4	45,0	ø20	40	M6x5	ø15	35	M6x1
X2T/17	2,700	104,4	45,0	ø20	40	M6x6	ø15	35	M6x1
X2T/19	2,800	108,4	45,0	ø20	40	M6x7	ø15	35	M6x1
X2T/22	2,950	114,4	52,5	ø20	40	M6x8	ø15	35	M6x1
X2T/26	3,050	118,4	52,5	ø20	40	M6x9	ø15	35	M6x1
X2T/30	3,300	126,4	60,7	ø20	40	M6x10	ø20	40	M6x1
X2T/34	3,500	133,4	60,7	ø20	40	M6x11	ø20	40	M6x1
X2T/40	3,700	142,4	60,7	ø20	40	M6x12	ø20	40	M6x1

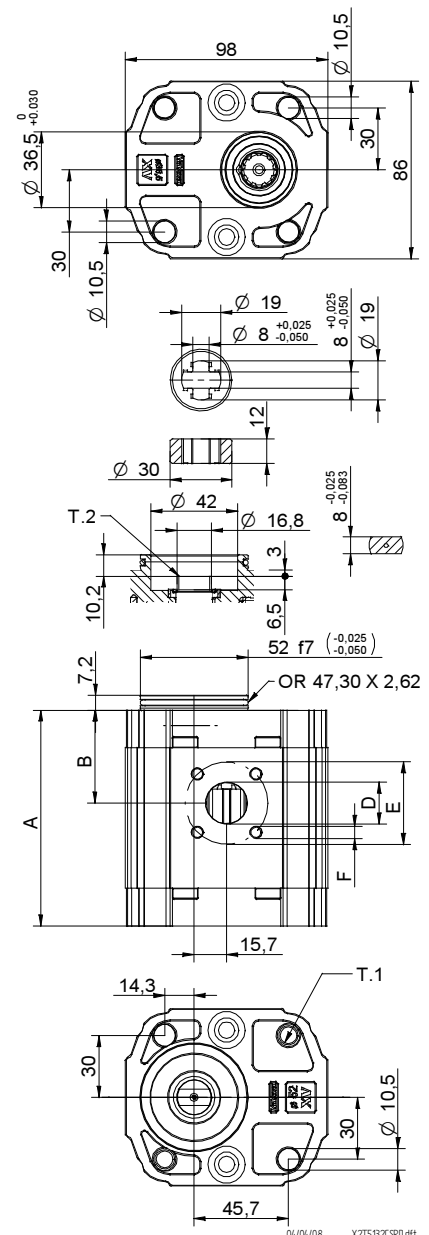

T.1 = 54÷58.9 [Nm] - screw tightening torque M10

T.2 = 60.5 [Nm] - admissible shaft torque (N.B. When choosing a shaft, always check the admissible torque).

Table of variations

X2T

Standard German ø52 "BH" FLANGE

Standard German ø52 "BH" FLANGE				Shaft		Cover		
Left rotation		Right rotation				Left rotation	Right rotation	
	31		32	CFP01 - Milled shank T.2 = 60.5 [Nm]	C	SCF05 - Splined T.2 = 86.2 [Nm] m=1.6 Z=9 DIN 5482 - 17x14		A
	33		34	SCI01 - Splined T.2 = 86.2 [Nm] m=1.6 Z=9 DIN 5482 - 17x14	L			D
	35		36					
	37		38					

Displacement	
TYPE	CODE
X2T/04	41
X2T/06	43
X2T/09	45
X2T/11	47
X2T/14	49
X2T/17	51
X2T/19	53
X2T/22	55
X2T/26	57
X2T/30	59
X2T/34	61
X2T/40	63

Standard bodies						
Displacement cm3/rev	Standard threads					
	4	O - O	S - R	B - B	L - M	Z - Z
6	O - O	S - R	B - B	L - M	Z - Z	
9	O - O	S - R	B - B	L - M	Z - Z	
11	O - O	S - R	B - B	L - M	Z - Z	
14	P - O	S - R	C - B	L - M	Z - Z	
17	P - O	S - R	C - B	L - M	Z - Z	
19	P - O	S - R	C - B	L - M	Z - Z	
22	P - O	S - R	C - B	L - M	Z - Z	
26	Q - P	S - R	D - C	L - M	Z - Z	
30	Q - P	S - S	D - C	L - M	Z - Z	
34	Q - P	S - S	D - C	L - M	Z - Z	
40	Q - P	S - S	D - C	L - M	Z - Z	

Table showing standard flange and thread combinations available in stock

Body (threads/flanges)													
	A		B		C		D		E		F		G
	H		I		L		M		N		O		P
	Q		R		S		T		U		V	Closed Body	Z

entrainment pump - series XV

X2T

GERMAN STANDARD DRIVING PUMP
 ø80 FLANGE - TAPER SHAFT

X 2 T 51 42 F S R A

Series	X	series XV
Group	2	group 2
Category	T	entrainment pump
Displacement	51	17
Flange	42	Ø80 GERMAN STANDARDIZED right rotation (with OR)
Shaft	F	COP02 - Tapered 1:5 - ø17.4 - M12x1.5 - key thk.3
Body	IN	inlet - Ø40 a 45° Ø20 M6
	OUT	outlet - Ø35 a 45° Ø15 M6
Cover	A	ø36,5 female cover for left multiple pump element

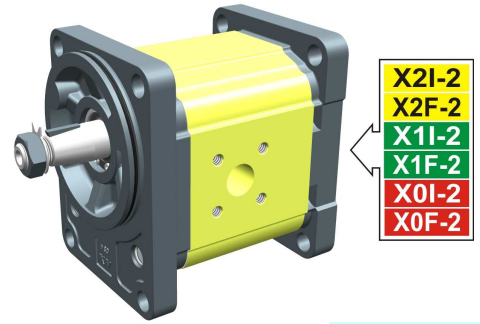

XT217

Technical data table

TYPE	Displacement cm3/rev	Max. Pressure		CODE	
		P1 bar	P3 bar		
				Left rotation	Right rotation
X2T/04	4,20	260	300	X 2 T 41 41 F S R A	X 2 T 41 42 F S R A
X2T/06	6,00	260	300	X 2 T 43 41 F S R A	X 2 T 43 42 F S R A
X2T/09	8,40	260	300	X 2 T 45 41 F S R A	X 2 T 45 42 F S R A
X2T/11	10,80	260	300	X 2 T 47 41 F S R A	X 2 T 47 42 F S R A
X2T/14	14,40	250	290	X 2 T 49 41 F S R A	X 2 T 49 42 F S R A
X2T/17	16,80	230	270	X 2 T 51 41 F S R A	X 2 T 51 42 F S R A
X2T/19	19,20	210	250	X 2 T 53 41 F S R A	X 2 T 53 42 F S R A
X2T/22	22,80	200	240	X 2 T 55 41 F S R A	X 2 T 55 42 F S R A
X2T/26	26,20	170	210	X 2 T 57 41 F S R A	X 2 T 57 42 F S R A
X2T/30	30,00	160	200	X 2 T 59 41 F S S A	X 2 T 59 42 F S S A
X2T/34	34,20	150	190	X 2 T 61 41 F S S A	X 2 T 61 42 F S S A
X2T/40	39,60	140	180	X 2 T 63 41 F S S A	X 2 T 63 42 F S S A

P1) Max. working pressure - P3) Max. peak pressure

For heavy-duty applications, it is recommended to check the admissible torque of the shaft

Dimensions table

TYPE	Weight kg	Dimensions							
		A	B	D	E	F	D	E	F
		mm	mm	IN			OUT		
X2T/04	2,330	85,9	41,1	ø20	40	M6x1	ø15	35	M6x1
X2T/06	2,430	88,9	41,1	ø20	40	M6x2	ø15	35	M6x1
X2T/09	2,530	92,9	43,1	ø20	40	M6x3	ø15	35	M6x1
X2T/11	2,630	96,9	47,5	ø20	40	M6x4	ø15	35	M6x1
X2T/14	2,730	102,9	47,5	ø20	40	M6x5	ø15	35	M6x1
X2T/17	2,830	106,9	47,5	ø20	40	M6x6	ø15	35	M6x1
X2T/19	2,930	110,9	47,5	ø20	40	M6x7	ø15	35	M6x1
X2T/22	3,180	116,9	55,0	ø20	40	M6x8	ø15	35	M6x1
X2T/26	3,280	120,9	55,0	ø20	40	M6x9	ø15	35	M6x1
X2T/30	3,530	128,9	63,2	ø20	40	M6x10	ø20	40	M6x1
X2T/34	3,730	135,9	63,2	ø20	40	M6x11	ø20	40	M6x1
X2T/40	3,930	144,9	63,2	ø20	40	M6x12	ø20	40	M6x1

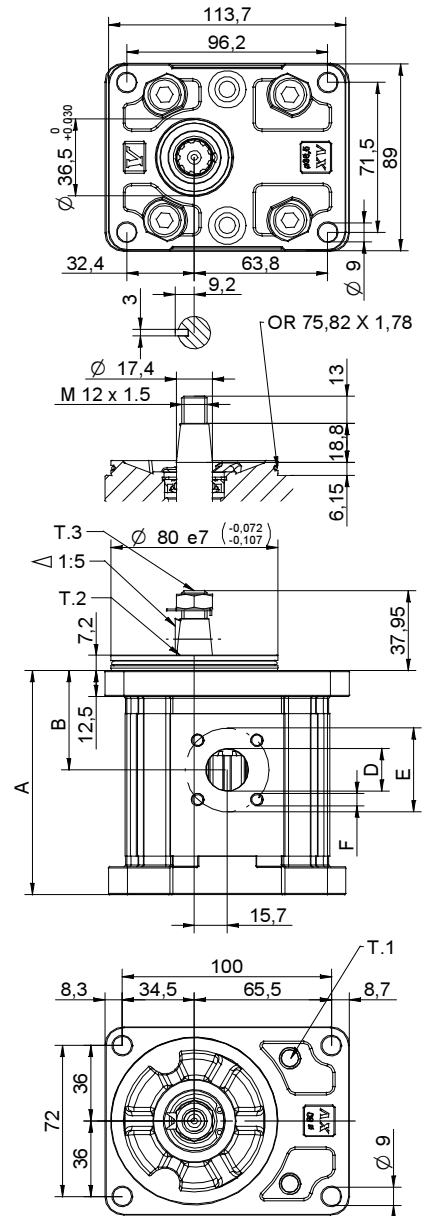

T.1 = 54÷58.9 [Nm] - screw tightening torque M10

T.3 = 40 [Nm] - torque wrench setting 19

T.2 = 233.2 [Nm] - admissible shaft torque (N.B. When choosing a shaft, always check the admissible torque).

Table of variations

X2T

ø80 FLANGE

ø80 FLANGE		Shaft		Cover	
Left rotation	Right rotation			Left rotation	Right rotation
		CIP01 - Parallel T.2 = 44.1 [Nm] 	CIP02 - Parallel T.2 = 67.5 [Nm] 		
41	42	A	B	A	A
		COP01 - Tapered T.2 = 233.2 [Nm] 	COP02 - Tapered T.2 = 233.2 [Nm] 		
		E	F	D	D
		SCP03 - Splined T.2 = 86.2 [Nm] 	H		

Displacement	
TYPE	CODE
X2T/04	41
X2T/06	43
X2T/09	45
X2T/11	47
X2T/14	49
X2T/17	51
X2T/19	53
X2T/22	55
X2T/26	57
X2T/30	59
X2T/34	61
X2T/40	63

Standard bodies						
Displacement cm3/rev	Standard threads					
	4	O - O	S - R	B - B	L - M	Z - Z
6	O - O	S - R	B - B	L - M	Z - Z	Z - Z
9	O - O	S - R	B - B	L - M	Z - Z	Z - Z
11	O - O	S - R	B - B	L - M	Z - Z	Z - Z
14	P - O	S - R	C - B	L - M	Z - Z	Z - Z
17	P - O	S - R	C - B	L - M	Z - Z	Z - Z
19	P - O	S - R	C - B	L - M	Z - Z	Z - Z
22	P - O	S - R	C - B	L - M	Z - Z	Z - Z
26	Q - P	S - R	D - C	L - M	Z - Z	Z - Z
30	Q - P	S - S	D - C	L - M	Z - Z	Z - Z
34	Q - P	S - S	D - C	L - M	Z - Z	Z - Z
40	Q - P	S - S	D - C	L - M	Z - Z	Z - Z

Table showing standard flange and thread combinations available in stock

Body (threads/flanges)													
	A		B		C		D		E		F		G
	H		I		L		M		N		O		P
	Q		R		S		T		U		V	Closed Body	Z

entrainment pump - series XV

X2T

"SAE A" DRIVING PUMP
ø82.5 FLANGE - SPLINED SHAFT

X 2 T 51 52 I S R A

Series	X	series XV
Group	2	group 2
Category	T	entrainment pump
Displacement	51	17
Flange	52	Ø82.5 SAE A right rotation (with OR)
Shaft	I	SCP04 - Splined ø15.456 z=9, H=22.5 - SAE J498 9T 16/32DP
Body	IN	inlet - Ø40 a 45° Ø20 M6
	OUT	outlet - Ø35 a 45° Ø15 M6
Cover	A	ø36,5 female cover for left multiple pump element

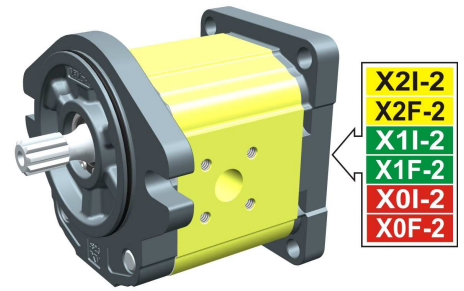

XT219

Technical data table

TYPE	Displacement cm3/rev	Max. Pressure		CODE	
		P1 bar	P3 bar	Left rotation	Right rotation
X2T/04	4,20	260	300	X 2 T 41 51 I S R A	X 2 T 41 52 I S R A
X2T/06	6,00	260	300	X 2 T 43 51 I S R A	X 2 T 43 52 I S R A
X2T/09	8,40	260	300	X 2 T 45 51 I S R A	X 2 T 45 52 I S R A
X2T/11	10,80	260	300	X 2 T 47 51 I S R A	X 2 T 47 52 I S R A
X2T/14	14,40	250	290	X 2 T 49 51 I S R A	X 2 T 49 52 I S R A
X2T/17	16,80	230	270	X 2 T 51 51 I S R A	X 2 T 51 52 I S R A
X2T/19	19,20	210	250	X 2 T 53 51 I S R A	X 2 T 53 52 I S R A
X2T/22	22,80	200	240	X 2 T 55 51 I S R A	X 2 T 55 52 I S R A
X2T/26	26,20	170	210	X 2 T 57 51 I S R A	X 2 T 57 52 I S R A
X2T/30	30,00	160	200	X 2 T 59 51 I S S A	X 2 T 59 52 I S S A
X2T/34	34,20	150	190	X 2 T 61 51 I S S A	X 2 T 61 52 I S S A
X2T/40	39,60	140	180	X 2 T 63 51 I S S A	X 2 T 63 52 I S S A

P1) Max. working pressure - P3) Max. peak pressure

For heavy-duty applications, it is recommended to check the admissible torque of the shaft

Dimensions table

TYPE	Weight kg	A	B	D	E	F	D	E	F
		mm	mm	IN			OUT		
X2T/04	2,280	84,2	39,4	ø20	40	M6x1	ø15	35	M6x1
X2T/06	2,380	87,2	39,4	ø20	40	M6x2	ø15	35	M6x1
X2T/09	2,480	91,2	41,4	ø20	40	M6x3	ø15	35	M6x1
X2T/11	2,580	95,2	45,8	ø20	40	M6x4	ø15	35	M6x1
X2T/14	2,780	101,2	45,8	ø20	40	M6x5	ø15	35	M6x1
X2T/17	2,880	105,2	45,8	ø20	40	M6x6	ø15	35	M6x1
X2T/19	2,980	109,2	45,8	ø20	40	M6x7	ø15	35	M6x1
X2T/22	3,130	115,2	53,3	ø20	40	M6x8	ø15	35	M6x1
X2T/26	3,230	119,2	53,3	ø20	40	M6x9	ø15	35	M6x1
X2T/30	3,480	127,2	61,5	ø20	40	M6x10	ø20	40	M6x1
X2T/34	3,680	134,2	61,5	ø20	40	M6x11	ø20	40	M6x1
X2T/40	3,880	143,2	61,5	ø20	40	M6x12	ø20	40	M6x1

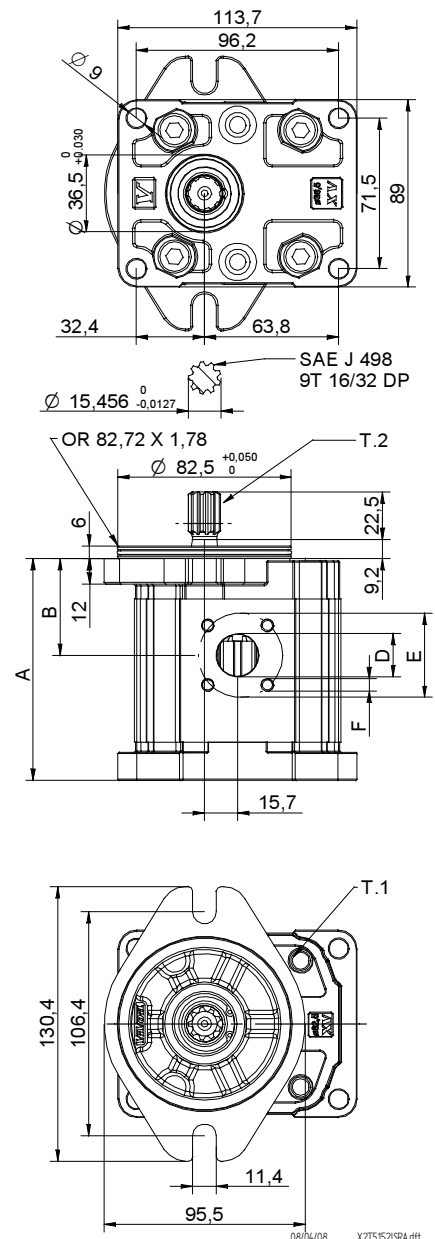

T.1 = 54÷58.9 [Nm] - screw tightening torque M10

T.2 = 67.1 [Nm] - admissible shaft torque (N.B. When choosing a shaft, always check the admissible torque).

Table of variations

X2T

ø82.5 FLANGE "SAE A"

ø82.5 FLANGE "SAE A"				Shaft				Cover		
Left rotation		Right rotation		CIP01 - Parallel		CIP02 - Parallel		Left rotation	Right rotation	
	51		52		A		B			A
	53		54		E		F			D
Without OR		Without OR		SCP04 - Splined						
				T.2 = 233,2 [Nm]		T.2 = 233,2 [Nm]				
				T.2 = 44.1 [Nm]		T.2 = 67.5 [Nm]				
				T.2 = 67.1 [Nm]						

Displacement	
TYPE	CODE
X2T/04	41
X2T/06	43
X2T/09	45
X2T/11	47
X2T/14	49
X2T/17	51
X2T/19	53
X2T/22	55
X2T/26	57
X2T/30	59
X2T/34	61
X2T/40	63

Standard bodies						
Displacement cm3/rev	Standard threads					
	4	O - O	S - R	B - B	L - M	Z - Z
6	O - O	S - R	B - B	L - M	Z - Z	
9	O - O	S - R	B - B	L - M	Z - Z	
11	O - O	S - R	B - B	L - M	Z - Z	
14	P - O	S - R	C - B	L - M	Z - Z	
17	P - O	S - R	C - B	L - M	Z - Z	
19	P - O	S - R	C - B	L - M	Z - Z	
22	P - O	S - R	C - B	L - M	Z - Z	
26	Q - P	S - R	D - C	L - M	Z - Z	
30	Q - P	S - S	D - C	L - M	Z - Z	
34	Q - P	S - S	D - C	L - M	Z - Z	
40	Q - P	S - S	D - C	L - M	Z - Z	

Table showing standard flange and thread combinations available in stock

Body (threads/flanges)													
	A		B		C		D		E		F		G
	H		I		L		M		N		O		P
	Q		R		S		T		U		V	Closed Body	Z

intermediate pump - series XV

X2I-2

**STANDARD FINAL PUMP
FEMALE Ø36,5 FLANGE**

X 2 I 51 02 P P O A

Series	X	series XV
Group	2	group 2
Category	I	intermediate pump
Displacement	51	17
Flange	02	Ø36.5 female right rotation 2P+2P, 3P+2P
Shaft	P	SCI01 - Intermediate
Body	IN	inlet - Ø40 Ø20 M8
	OUT	outlet - Ø30 Ø13.5 M6
Cover	A	Ø36,5 female cover for left multiple pump element

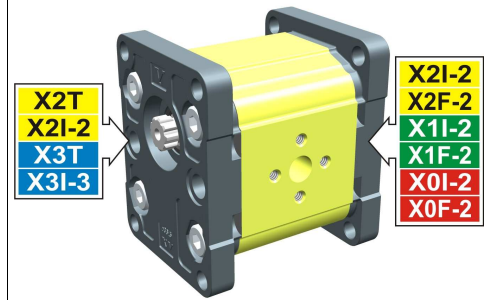

XI201

Technical data table

TYPE	Displacement cm3/rev	Max. Pressure		CODE																	
		P1 bar	P3 bar	Left rotation			Right rotation														
				IN	OUT	COVER	IN	OUT	COVER												
X2I-2/04	4,20	260	300	X	2	I	41	01	P	O	O	A	X	2	I	41	02	P	O	O	A
X2I-2/06	6,00	260	300	X	2	I	43	01	P	O	O	A	X	2	I	43	02	P	O	O	A
X2I-2/09	8,40	260	300	X	2	I	45	01	P	O	O	A	X	2	I	45	02	P	O	O	A
X2I-2/11	10,80	260	300	X	2	I	47	01	P	O	O	A	X	2	I	47	02	P	O	O	A
X2I-2/14	14,40	250	290	X	2	I	49	01	P	P	O	A	X	2	I	49	02	P	P	O	A
X2I-2/17	16,80	230	270	X	2	I	51	01	P	P	O	A	X	2	I	51	02	P	P	O	A
X2I-2/19	19,20	210	250	X	2	I	53	01	P	P	O	A	X	2	I	53	02	P	P	O	A
X2I-2/22	22,80	200	240	X	2	I	55	01	P	P	O	A	X	2	I	55	02	P	P	O	A
X2I-2/26	26,20	170	210	X	2	I	57	01	P	Q	P	A	X	2	I	57	02	P	Q	P	A
X2I-2/30	30,00	160	200	X	2	I	59	01	P	Q	P	A	X	2	I	59	02	P	Q	P	A
X2I-2/34	34,20	150	190	X	2	I	61	01	P	Q	P	A	X	2	I	61	02	P	Q	P	A
X2I-2/40	39,60	140	180	X	2	I	63	01	P	Q	P	A	X	2	I	63	02	P	Q	P	A

P1) Max. working pressure - P3) Max. peak pressure

For heavy-duty applications, it is recommended to check the admissible torque of the shaft

Dimensions table

TYPE	Weight kg	A	B	D	E	F	D	E	F
		mm	mm	IN			OUT		
X2I-2/04	2,200	83,4	41,7	Ø13,5	30	M6x1	Ø13,5	30	M6x1
X2I-2/06	2,300	86,4	43,2	Ø13,5	30	M6x1	Ø13,5	30	M6x1
X2I-2/09	2,400	90,4	45,2	Ø13,5	30	M6x1	Ø13,5	30	M6x1
X2I-2/11	2,500	94,4	47,2	Ø13,5	30	M6x1	Ø13,5	30	M6x1
X2I-2/14	2,700	100,4	50,2	Ø20	40	M8X1,25	Ø13,5	30	M6x1
X2I-2/17	2,800	104,4	52,2	Ø20	40	M8X1,25	Ø13,5	30	M6x1
X2I-2/19	2,900	108,4	54,2	Ø20	40	M8X1,25	Ø13,5	30	M6x1
X2I-2/22	3,050	114,4	57,2	Ø20	40	M8X1,25	Ø13,5	30	M6x1
X2I-2/26	3,150	118,4	59,2	Ø23,5	40	M8X1,25	Ø20	40	M8X1,25
X2I-2/30	3,400	126,4	63,2	Ø23,5	40	M8X1,25	Ø20	40	M8X1,25
X2I-2/34	3,600	133,4	66,7	Ø23,5	40	M8X1,25	Ø20	40	M8X1,25
X2I-2/40	3,800	142,4	71,2	Ø23,5	40	M8X1,25	Ø20	40	M8X1,25

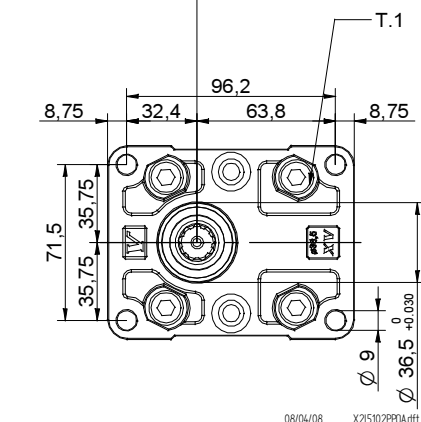
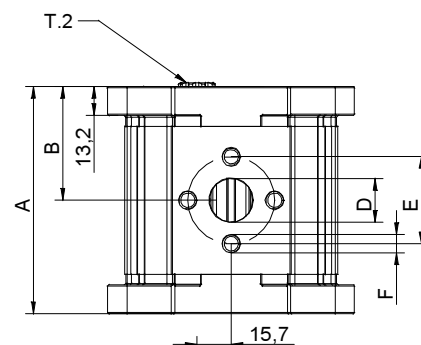
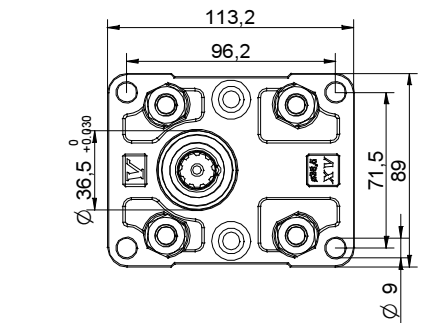

08/04/08 X2I5102PP0A.dft





T.1 = 54÷58.9 [Nm] - screw tightening torque M10

T.2 = 86.2 [Nm] - admissible shaft torque (N.B. When choosing a shaft, always check the admissible torque).

Table of variations

X2I-2

Standard female $\varnothing 36.5$ FLANGE

Standard female $\varnothing 36.5$ FLANGE		Shaft		Cover			
Left rotation	Right rotation			Left rotation	Right rotation		
	01		02	SCI01 - Splined $T.2 = 86.2$ [Nm] $m=1.6$ $Z=9$ DIN 5482 - 17x14 			A
						D	

Displacement	
TYPE	CODE
X2I-2/04	41
X2I-2/06	43
X2I-2/09	45
X2I-2/11	47
X2I-2/14	49
X2I-2/17	51
X2I-2/19	53
X2I-2/22	55
X2I-2/26	57
X2I-2/30	59
X2I-2/34	61
X2I-2/40	63

Standard bodies				
Displacement cm3/rev	Standard threads			
	4	O - O	S - R	B - B
6	O - O	S - R	B - B	L - M
9	O - O	S - R	B - B	L - M
11	O - O	S - R	B - B	L - M
14	P - O	S - R	C - B	L - M
17	P - O	S - R	C - B	L - M
19	P - O	S - R	C - B	L - M
22	P - O	S - R	C - B	L - M
26	Q - P	S - R	D - C	L - M
30	Q - P	S - S	D - C	L - M
34	Q - P	S - S	D - C	L - M
40	Q - P	S - S	D - C	L - M

Table showing standard flange and thread combinations available in stock

Body (threads/flanges)													
	A		B		C		D		E		F		G
	H		I		L		M		N		O		P
	Q		R		S		T		U		V	Closed Body	Z

intermediate pump - series XV

X2I-2

SHAPED FINAL PUMP
SHAPED FEMALE $\varnothing 36,5$ FLANGE

X 2 I 51 72 P P O D

Series	X	series XV
Group	2	group 2
Category	I	intermediate pump
Displacement	51	17
Flange	72	$\varnothing 36.5$ body-shaped female right rotation 2P+2P
Shaft	P	SCI01 - Intermediate
Body	IN	inlet - $\varnothing 40 \varnothing 20$ M8
	OUT	outlet - $\varnothing 30 \varnothing 13.5$ M6
Cover	D	$\varnothing 36,5$ body-shaped female cover for left multiple pump element

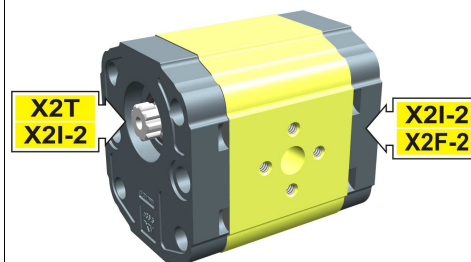

XI202

Technical data table

TYPE	Displacement cm3/rev	Max. Pressure		CODE	
		P1 bar	P3 bar	Left rotation	Right rotation
X2I-2/04	4,20	260	300	X 2 I 41 71 P O O D	X 2 I 41 72 P O O D
X2I-2/06	6,00	260	300	X 2 I 43 71 P O O D	X 2 I 43 72 P O O D
X2I-2/09	8,40	260	300	X 2 I 45 71 P O O D	X 2 I 45 72 P O O D
X2I-2/11	10,80	260	300	X 2 I 47 71 P O O D	X 2 I 47 72 P O O D
X2I-2/14	14,40	250	290	X 2 I 49 71 P O D D	X 2 I 49 72 P P O D
X2I-2/17	16,80	230	270	X 2 I 51 71 P P O D	X 2 I 51 72 P P O D
X2I-2/19	19,20	210	250	X 2 I 53 71 P P O D	X 2 I 53 72 P P O D
X2I-2/22	22,80	200	240	X 2 I 55 71 P P O D	X 2 I 55 72 P P O D
X2I-2/26	26,20	170	210	X 2 I 57 71 P Q P D	X 2 I 57 72 P Q P D
X2I-2/30	30,00	160	200	X 2 I 59 71 P Q P D	X 2 I 59 72 P Q P D
X2I-2/34	34,20	150	190	X 2 I 61 71 P Q P D	X 2 I 61 72 P Q P D
X2I-2/40	39,60	140	180	X 2 I 63 71 P Q P D	X 2 I 63 72 P Q P D

P1) Max. working pressure - P3) Max. peak pressure

For heavy-duty applications, it is recommended to check the admissible torque of the shaft

Dimensions table

TYPE	Weight kg	A	B	D	E	F	D	E	F
		mm	mm	IN			OUT		
X2I-2/04	2,200	83,4	41,7	$\varnothing 13,5$	30	M6x1	$\varnothing 13,5$	30	M6x1
X2I-2/06	2,300	86,4	43,2	$\varnothing 13,5$	30	M6x1	$\varnothing 13,5$	30	M6x1
X2I-2/09	2,400	90,4	45,2	$\varnothing 13,5$	30	M6x1	$\varnothing 13,5$	30	M6x1
X2I-2/11	2,500	94,4	47,2	$\varnothing 13,5$	30	M6x1	$\varnothing 13,5$	30	M6x1
X2I-2/14	2,700	100,4	50,2	$\varnothing 20$	40	M8X1,25	$\varnothing 13,5$	30	M6x1
X2I-2/17	2,800	104,4	52,2	$\varnothing 20$	40	M8X1,25	$\varnothing 13,5$	30	M6x1
X2I-2/19	2,900	108,4	54,2	$\varnothing 20$	40	M8X1,25	$\varnothing 13,5$	30	M6x1
X2I-2/22	3,050	114,4	57,2	$\varnothing 20$	40	M8X1,25	$\varnothing 13,5$	30	M6x1
X2I-2/26	3,150	118,4	59,2	$\varnothing 23,5$	40	M8X1,25	$\varnothing 20$	40	M8X1,25
X2I-2/30	3,400	126,4	63,2	$\varnothing 23,5$	40	M8X1,25	$\varnothing 20$	40	M8X1,25
X2I-2/34	3,600	133,4	66,7	$\varnothing 23,5$	40	M8X1,25	$\varnothing 20$	40	M8X1,25
X2I-2/40	3,800	142,4	71,2	$\varnothing 23,5$	40	M8X1,25	$\varnothing 20$	40	M8X1,25

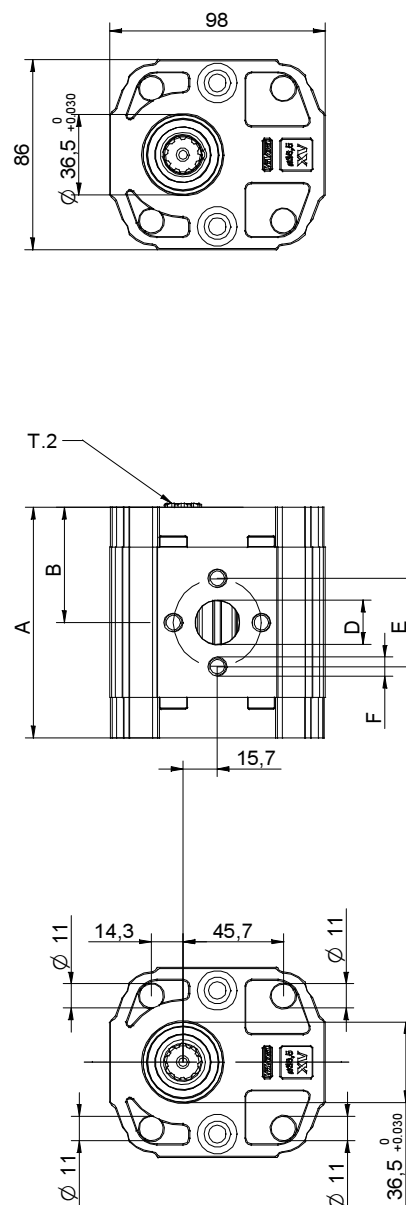

29/04/08 X2I5172PP01.dft

T.2 = 86.2 [Nm] - admissible shaft torque (N.B. When choosing a shaft, always check the admissible torque).

Table of variations

X2I-2

Shaped female $\varnothing 36.5$ FLANGE

Shaped female $\varnothing 36.5$ FLANGE				Shaft		Cover		
Left rotation		Right rotation				Left rotation	Right rotation	
	71		72	SCI01 - Splined $T.2 = 86.2$ [Nm] $m=1.6$ $Z=9$ DIN 5482 - 17x14 	P			A
								D

Displacement	
TYPE	CODE
X2I-2/04	41
X2I-2/06	43
X2I-2/09	45
X2I-2/11	47
X2I-2/14	49
X2I-2/17	51
X2I-2/19	53
X2I-2/22	55
X2I-2/26	57
X2I-2/30	59
X2I-2/34	61
X2I-2/40	63

Standard bodies				
Displacement cm3/rev	Standard threads			
	4	O - O	S - R	B - B
6	O - O	S - R	B - B	L - M
9	O - O	S - R	B - B	L - M
11	O - O	S - R	B - B	L - M
14	P - O	S - R	C - B	L - M
17	P - O	S - R	C - B	L - M
19	P - O	S - R	C - B	L - M
22	P - O	S - R	C - B	L - M
26	Q - P	S - R	D - C	L - M
30	Q - P	S - S	D - C	L - M
34	Q - P	S - S	D - C	L - M
40	Q - P	S - S	D - C	L - M

Table showing standard flange and thread combinations available in stock

Body (threads/flanges)													
	A		B		C		D		E		F		G
	H		I		L		M		N		O		P
	Q		R		S		T		U		V	Closed Body	Z

final pump - series XV

X2F-2

STANDARD FINAL PUMP
FEMALE Ø36,5 FLANGE

X 2 F 51 02 Q P O A

Series	X	series XV
Group	2	group 2
Category	F	final pump
Displacement	51	17
Flange	02	Ø36.5 female right rotation 2P+2P, 3P+2P
Shaft	Q	SCF01 - Final
Body	IN	inlet - Ø40 Ø20 M8
	OUT	outlet - Ø30 Ø13.5 M6
Cover	A	standard

X2T
X2I-2
X3T
X3I-3

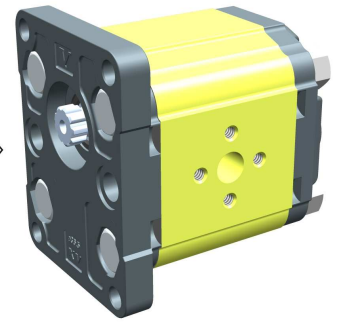

XF201

Technical data table

TYPE	Displacement cm3/rev	Max. Pressure		CODE																	
		P1 bar	P3 bar	Left rotation			Right rotation														
X2F-2/04	4,20	260	300	X	2	F	41	01	Q	O	O	A	X	2	F	41	02	Q	O	O	A
X2F-2/06	6,00	260	300	X	2	F	43	01	Q	O	O	A	X	2	F	43	02	Q	O	O	A
X2F-2/09	8,40	260	300	X	2	F	45	01	Q	O	O	A	X	2	F	45	02	Q	O	O	A
X2F-2/11	10,80	260	300	X	2	F	47	01	Q	O	O	A	X	2	F	47	02	Q	O	O	A
X2F-2/14	14,40	250	290	X	2	F	49	01	Q	P	O	A	X	2	F	49	02	Q	P	O	A
X2F-2/17	16,80	230	270	X	2	F	51	01	Q	P	O	A	X	2	F	51	02	Q	P	O	A
X2F-2/19	19,20	210	250	X	2	F	53	01	Q	P	O	A	X	2	F	53	02	Q	P	O	A
X2F-2/22	22,80	200	240	X	2	F	55	01	Q	P	O	A	X	2	F	55	02	Q	P	O	A
X2F-2/26	26,20	170	210	X	2	F	57	01	Q	Q	P	A	X	2	F	57	02	Q	Q	P	A
X2F-2/30	30,00	160	200	X	2	F	59	01	Q	Q	P	A	X	2	F	59	02	Q	Q	P	A
X2F-2/34	34,20	150	190	X	2	F	61	01	Q	Q	P	A	X	2	F	61	02	Q	Q	P	A
X2F-2/40	39,60	140	180	X	2	F	63	01	Q	Q	P	A	X	2	F	63	02	Q	Q	P	A

P1) Max. working pressure - P3) Max. peak pressure

For heavy-duty applications, it is recommended to check the admissible torque of the shaft

Dimensions table

TYPE	Weight kg	A	B	D	E	F	D	E	F
		mm	mm	IN			OUT		
X2F-2/04	2,200	87,2	41,7	Ø13,5	30	M6x1	Ø13,5	30	M6x1
X2F-2/06	2,300	90,2	43,2	Ø13,5	30	M6x1	Ø13,5	30	M6x1
X2F-2/09	2,400	94,2	45,2	Ø13,5	30	M6x1	Ø13,5	30	M6x1
X2F-2/11	2,500	98,2	47,2	Ø13,5	30	M6x1	Ø13,5	30	M6x1
X2F-2/14	2,700	104,2	50,2	Ø20	40	M8X1,25	Ø13,5	30	M6x1
X2F-2/17	2,800	108,2	52,2	Ø20	40	M8X1,25	Ø13,5	30	M6x1
X2F-2/19	2,900	112,2	54,2	Ø20	40	M8X1,25	Ø13,5	30	M6x1
X2F-2/22	3,050	118,2	57,2	Ø20	40	M8X1,25	Ø13,5	30	M6x1
X2F-2/26	3,150	122,2	59,2	Ø23,5	40	M8X1,25	Ø20	40	M8X1,25
X2F-2/30	3,400	130,2	63,2	Ø23,5	40	M8X1,25	Ø20	40	M8X1,25
X2F-2/34	3,600	137,2	66,7	Ø23,5	40	M8X1,25	Ø20	40	M8X1,25
X2F-2/40	3,800	146,2	71,2	Ø23,5	40	M8X1,25	Ø20	40	M8X1,25

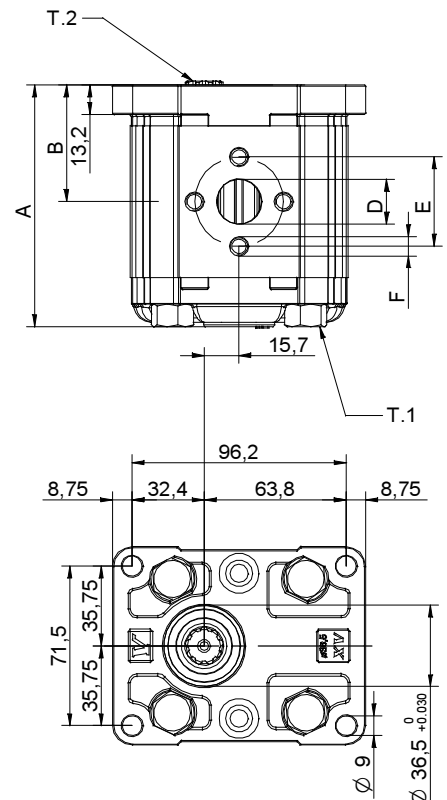
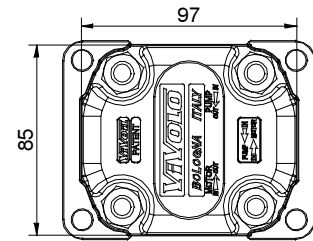

08/04/08 X2F5102P0A.dft



T.1 = 54÷58.9 [Nm] - screw tightening torque M10

T.2 = 86.2 [Nm] - admissible shaft torque (N.B. When choosing a shaft, always check the admissible torque).

Table of variations

X2F-2

Standard female $\varnothing 36.5$ FLANGE

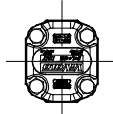
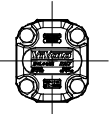
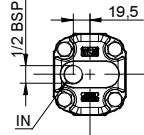
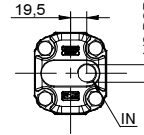
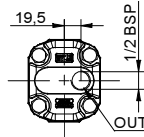
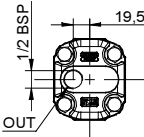
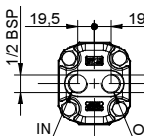
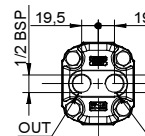
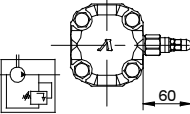
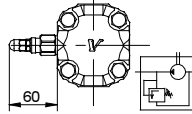
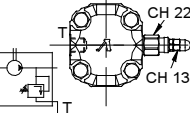
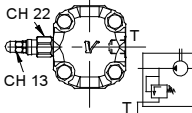
Standard female $\varnothing 36.5$ FLANGE		Shaft		Cover		
Left rotation	Right rotation			Left rotation	Right rotation	
		SCF01 - Splined T.2 = 86.2 [Nm] m=1.6 Z=9 DIN 5482 - 17x14 				A
01	02	Q				B
						C
						D
						N
				Internal drainage		
						O
				External drainage		

Displacement	
TYPE	CODE
X2F-2/04	41
X2F-2/06	43
X2F-2/09	45
X2F-2/11	47
X2F-2/14	49
X2F-2/17	51
X2F-2/19	53
X2F-2/22	55
X2F-2/26	57
X2F-2/30	59
X2F-2/34	61
X2F-2/40	63

Standard bodies						
Displacement cm3/rev	Standard threads					
	4	O - O	S - R	B - B	L - M	Z - Z
6	O - O	S - R	B - B	L - M	Z - Z	Z - Z
9	O - O	S - R	B - B	L - M	Z - Z	Z - Z
11	O - O	S - R	B - B	L - M	Z - Z	Z - Z
14	P - O	S - R	C - B	L - M	Z - Z	Z - Z
17	P - O	S - R	C - B	L - M	Z - Z	Z - Z
19	P - O	S - R	C - B	L - M	Z - Z	Z - Z
22	P - O	S - R	C - B	L - M	Z - Z	Z - Z
26	Q - P	S - R	D - C	L - M	Z - Z	Z - Z
30	Q - P	S - S	D - C	L - M	Z - Z	Z - Z
34	Q - P	S - S	D - C	L - M	Z - Z	Z - Z
40	Q - P	S - S	D - C	L - M	Z - Z	Z - Z

Table showing standard flange and thread combinations available in stock

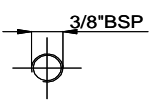
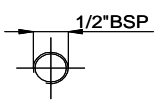
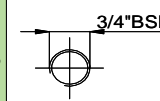
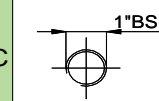
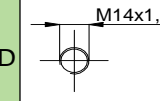
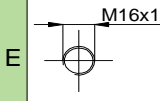
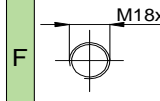
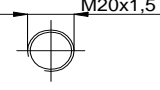
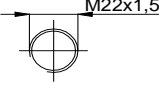
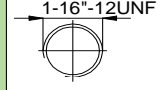
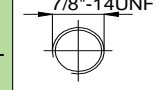
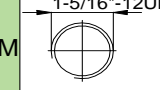
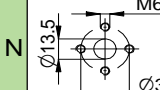
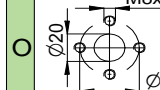
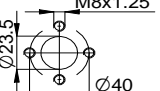
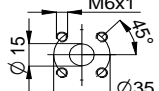
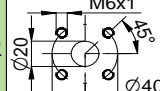
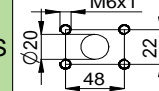
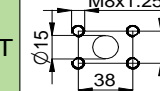
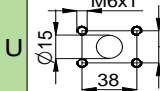
Body (threads/flanges)													
	A		B		C		D		E		F		G
	H		I		L		M		N		O		P
	Q		R		S		T		U		V	Closed Body	Z

final pump - series XV

X2F-2

SHAPED FINAL PUMP
SHAPED FEMALE $\varnothing 36,5$ FLANGE

X 2 F 51 72 Q P O A

Series	X	series XV
Group	2	group 2
Category	F	final pump
Displacement	51	17
Flange	72	$\varnothing 36.5$ body-shaped female right rotation 2P+2P
Shaft	Q	SCF01 - Final
Body	IN	inlet - $\varnothing 40 \varnothing 20$ M8
	OUT	outlet - $\varnothing 30 \varnothing 13.5$ M6
Cover	A	standard

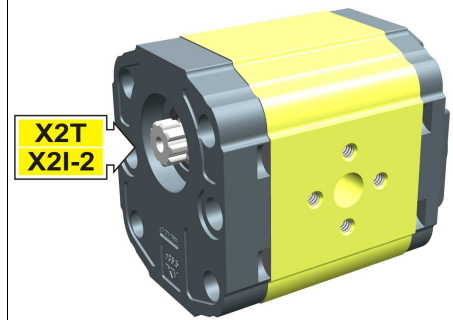

XF202

Technical data table

TYPE	Displacement cm3/rev	Max. Pressure		CODE	
		P1 bar	P3 bar	Left rotation	Right rotation
X2F-2/04	4,20	260	300	X 2 F 41 71 Q O O A	X 2 F 41 72 Q O O A
X2F-2/06	6,00	260	300	X 2 F 43 71 Q O O A	X 2 F 43 72 Q O O A
X2F-2/09	8,40	260	300	X 2 F 45 71 Q O O A	X 2 F 45 72 Q O O A
X2F-2/11	10,80	260	300	X 2 F 47 71 Q O O A	X 2 F 47 72 Q O O A
X2F-2/14	14,40	250	290	X 2 F 49 71 Q P O A	X 2 F 49 72 Q P O A
X2F-2/17	16,80	230	270	X 2 F 51 71 Q P O A	X 2 F 51 72 Q P O A
X2F-2/19	19,20	210	250	X 2 F 53 71 Q P O A	X 2 F 53 72 Q P O A
X2F-2/22	22,80	200	240	X 2 F 55 71 Q P O A	X 2 F 55 72 Q P O A
X2F-2/26	26,20	170	210	X 2 F 57 71 Q Q P A	X 2 F 57 72 Q Q P A
X2F-2/30	30,00	160	200	X 2 F 59 71 Q Q P A	X 2 F 59 72 Q Q P A
X2F-2/34	34,20	150	190	X 2 F 61 71 Q Q P A	X 2 F 61 72 Q Q P A
X2F-2/40	39,60	140	180	X 2 F 63 71 Q Q P A	X 2 F 63 72 Q Q P A

P1) Max. working pressure - P3) Max. peak pressure

For heavy-duty applications, it is recommended to check the admissible torque of the shaft

Dimensions table

TYPE	Weight kg	A	B	D	E	F	D	E	F
		mm	mm	IN			OUT		
X2F-2/04	2,200	87,2	41,7	$\varnothing 13,5$	30	M6x1	$\varnothing 13,5$	30	M6x1
X2F-2/06	2,300	90,2	43,2	$\varnothing 13,5$	30	M6x1	$\varnothing 13,5$	30	M6x1
X2F-2/09	2,400	94,2	45,2	$\varnothing 13,5$	30	M6x1	$\varnothing 13,5$	30	M6x1
X2F-2/11	2,500	98,2	47,2	$\varnothing 13,5$	30	M6x1	$\varnothing 13,5$	30	M6x1
X2F-2/14	2,700	104,2	50,2	$\varnothing 20$	40	M8X1,25	$\varnothing 13,5$	30	M6x1
X2F-2/17	2,800	108,2	52,2	$\varnothing 20$	40	M8X1,25	$\varnothing 13,5$	30	M6x1
X2F-2/19	2,900	112,2	54,2	$\varnothing 20$	40	M8X1,25	$\varnothing 13,5$	30	M6x1
X2F-2/22	3,050	118,2	57,2	$\varnothing 20$	40	M8X1,25	$\varnothing 13,5$	30	M6x1
X2F-2/26	3,150	122,2	59,2	$\varnothing 23,5$	40	M8X1,25	$\varnothing 20$	40	M8X1,25
X2F-2/30	3,400	130,2	63,2	$\varnothing 23,5$	40	M8X1,25	$\varnothing 20$	40	M8X1,25
X2F-2/34	3,600	137,2	66,7	$\varnothing 23,5$	40	M8X1,25	$\varnothing 20$	40	M8X1,25
X2F-2/40	3,800	146,2	71,2	$\varnothing 23,5$	40	M8X1,25	$\varnothing 20$	40	M8X1,25

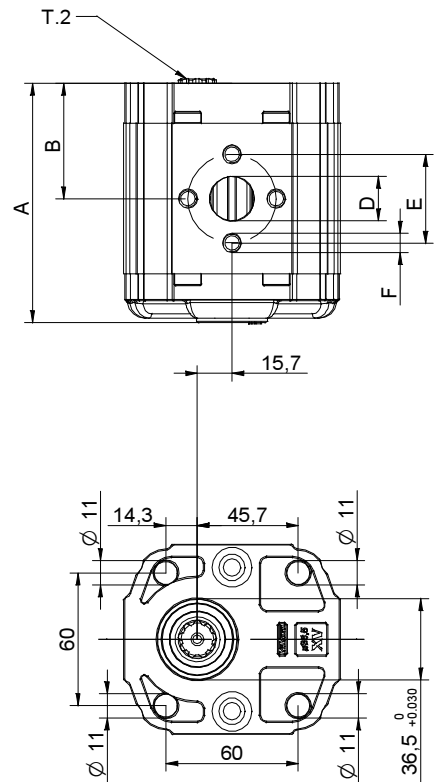
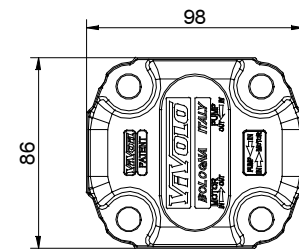



29/04/08 X2F5172P0A.dft

T.2 = 86.2 [Nm] - admissible shaft torque (N.B. When choosing a shaft, always check the admissible torque).

Table of variations

X2F-2

Shaped female $\varnothing 36.5$ FLANGE

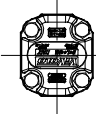
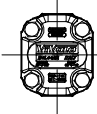
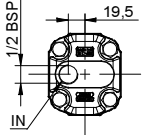
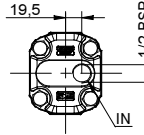
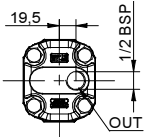
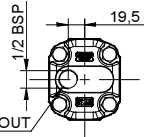
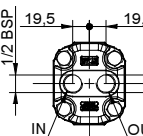
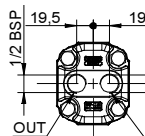
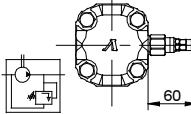
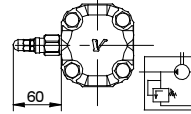
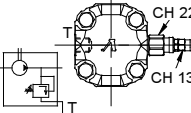
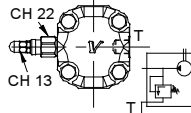
Shaped female $\varnothing 36.5$ FLANGE		Shaft		Cover					
Left rotation	Right rotation			Left rotation	Right rotation				
		71	72	SCF01 - Splined $T.2 = 86.2$ [Nm] $m=1.6$ $Z=9$ DIN 5482 - 17x14 		Q			A
						B			
						C			
						D			
						N	Internal drainage		
						O	External drainage		

Displacement	
TYPE	CODE
X2F-2/04	41
X2F-2/06	43
X2F-2/09	45
X2F-2/11	47
X2F-2/14	49
X2F-2/17	51
X2F-2/19	53
X2F-2/22	55
X2F-2/26	57
X2F-2/30	59
X2F-2/34	61
X2F-2/40	63

Standard bodies						
Displacement cm3/rev	Standard threads					
	4	O - O	S - R	B - B	L - M	Z - Z
6	O - O	S - R	B - B	L - M	Z - Z	Z - Z
9	O - O	S - R	B - B	L - M	Z - Z	Z - Z
11	O - O	S - R	B - B	L - M	Z - Z	Z - Z
14	P - O	S - R	C - B	L - M	Z - Z	Z - Z
17	P - O	S - R	C - B	L - M	Z - Z	Z - Z
19	P - O	S - R	C - B	L - M	Z - Z	Z - Z
22	P - O	S - R	C - B	L - M	Z - Z	Z - Z
26	Q - P	S - R	D - C	L - M	Z - Z	Z - Z
30	Q - P	S - S	D - C	L - M	Z - Z	Z - Z
34	Q - P	S - S	D - C	L - M	Z - Z	Z - Z
40	Q - P	S - S	D - C	L - M	Z - Z	Z - Z

Table showing standard flange and thread combinations available in stock

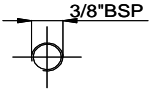
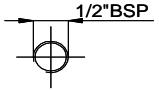
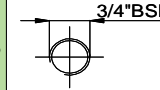
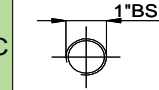
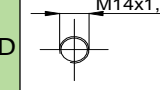
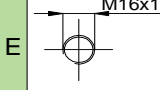
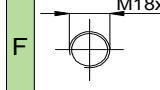
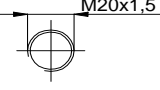
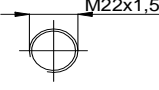
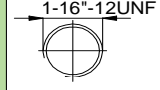
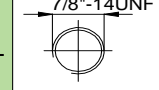
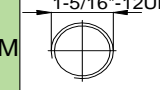
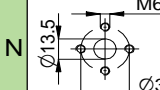
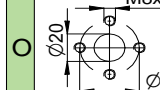
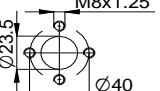
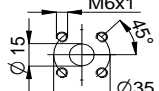
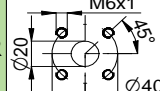
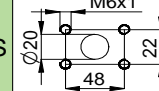
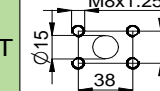
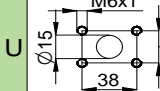
Body (threads/flanges)													
	A		B		C		D		E		F		G
	H		I		L		M		N		O		P
	Q		R		S		T		U		V	Closed Body	Z

entrainment pump - series XV

X3T

EUROPEAN STANDARD DRIVING PUMP
 ø50.8 FLANGE - TAPER SHAFT

X 3 T 78 02 A B B A

Series	X	series XV
Group	3	group 3
Category	T	entrainment pump
Displacement	78	38
Flange	02	Ø50.8 right rotation
Shaft	A	COP01 - Tapered 1:8 - ø22 - key thk.4
Body	IN	inlet - Ø51 Ø27 M10
	OUT	outlet - Ø51 Ø27 M10
Cover	A	ø50,8 female cover for left multiple pump element

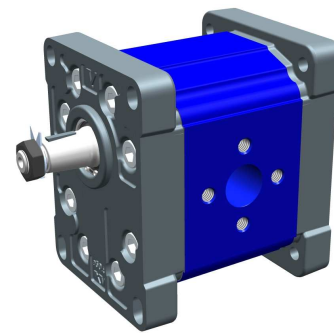

- X3I-3
- X3F-3
- X2I-2
- X2F-2
- X1I-2
- X1F-2
- X0I-2
- X0F-2

XT301

Technical data table																					
TYPE	Displacement cm3/rev	Max. Pressure		CODE																	
		P1 bar	P3 bar	Left rotation			Right rotation														
X3T/15	14,89	300	320	X	3	T	66	01	A	A	A	A	X	3	T	66	02	A	A	A	A
X3T/18	17,37	300	320	X	3	T	68	01	A	A	A	A	X	3	T	68	02	A	A	A	A
X3T/21	21,10	280	300	X	3	T	70	01	A	A	A	A	X	3	T	70	02	A	A	A	A
X3T/27	26,97	250	270	X	3	T	72	01	A	A	A	A	X	3	T	72	02	A	A	A	A
X3T/32	32,27	250	270	X	3	T	74	01	A	B	B	A	X	3	T	74	02	A	B	B	A
X3T/38	38,47	250	270	X	3	T	78	01	A	B	B	A	X	3	T	78	02	A	B	B	A
X3T/43	43,44	250	270	X	3	T	79	01	A	B	B	A	X	3	T	79	02	A	B	B	A
X3T/47	47,16	230	250	X	3	T	80	01	A	B	B	A	X	3	T	80	02	A	B	B	A
X3T/51	50,88	230	250	X	3	T	81	01	A	B	B	A	X	3	T	81	02	A	B	B	A
X3T/54	54,60	230	250	X	3	T	82	01	A	B	B	A	X	3	T	82	02	A	B	B	A
X3T/61	60,81	230	250	X	3	T	83	01	A	C	C	A	X	3	T	83	02	A	C	C	A
X3T/64	64,53	210	230	X	3	T	85	01	A	C	C	A	X	3	T	85	02	A	C	C	A
X3T/70	70,74	200	220	X	3	T	86	01	A	C	C	A	X	3	T	86	02	A	C	C	A
X3T/74	74,46	180	200	X	3	T	87	01	A	C	C	A	X	3	T	87	02	A	C	C	A
X3T/90	86,87	150	170	X	3	T	89	01	A	C	C	A	X	3	T	89	02	A	C	C	A

P1) Max. working pressure - P3) Max. peak pressure

For heavy-duty applications, it is recommended to check the admissible torque of the shaft

Dimensions table									
TYPE	Weight kg	A	B	D	E	F	D	E	F
		mm	mm	IN			OUT		
X3T/15	7,010	122,0	61,0	ø20	40	M8	ø20	40	M8
X3T/18	7,070	124,0	62,0	ø20	40	M8	ø20	40	M8
X3T/21	7,150	127,0	63,5	ø20	40	M8	ø20	40	M8
X3T/27	7,250	131,0	65,5	ø20	40	M8	ø20	40	M8
X3T/32	7,390	136,0	68,0	ø27	51	M10	ø27	51	M10
X3T/38	7,520	141,0	70,5	ø27	51	M10	ø27	51	M10
X3T/43	7,630	145,0	72,5	ø27	51	M10	ø27	51	M10
X3T/47	7,710	148,0	74,0	ø27	51	M10	ø27	51	M10
X3T/51	7,790	151,0	75,5	ø27	51	M10	ø27	51	M10
X3T/54	7,870	154,0	77,0	ø27	51	M10	ø27	51	M10
X3T/61	8,010	159,0	79,5	ø36	62	M10	ø36	62	M10
X3T/64	8,090	162,0	81,0	ø36	62	M10	ø36	62	M10
X3T/70	8,220	167,0	83,5	ø36	62	M10	ø36	62	M10
X3T/74	8,300	170,0	85,0	ø36	62	M10	ø36	62	M10
X3T/90	8,570	180,0	90,0	ø36	62	M10	ø36	62	M10

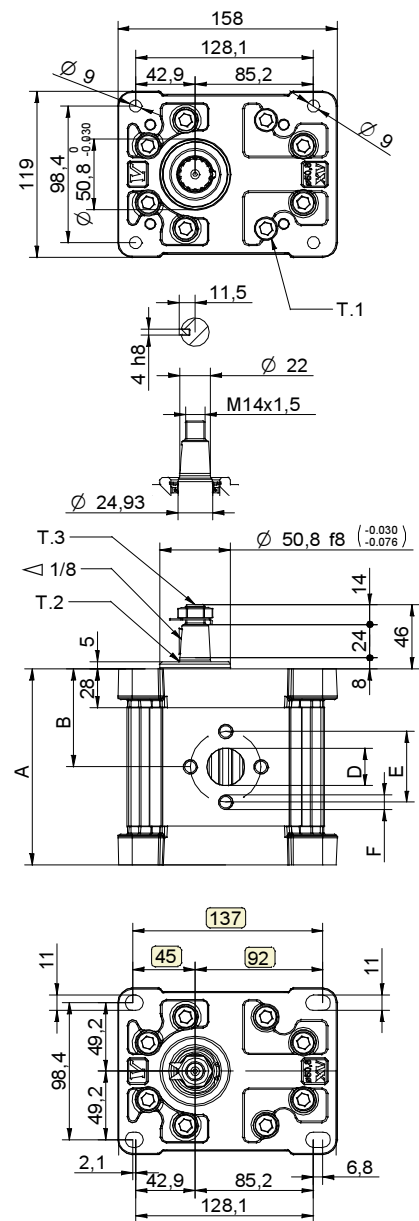

T.1 = 60÷65 [Nm] - screw tightening torque M10

T.3 = 75 [Nm] - torque wrench setting 22

T.2 = 482 [Nm] - admissible shaft torque (N.B. When choosing a shaft, always check the admissible torque).

Table of variations

X3T

ø50.8 FLANGE

ø50.8 FLANGE		Shaft		Cover	
Left rotation	Right rotation			Left rotation	Right rotation
		<p>COP01 - Tapered T.2 = 482 [Nm]</p>	<p>CIP01 - Parallel T.2 = 181 [Nm]</p>		
01	02	A	B		A
		<p>SCP03 - Splined T.2 = 223 [Nm]</p>	<p>CIP04 - Parallel T.2 = 180 [Nm]</p>		
		C	H		
		<p>SCP04 - Splined T.2 = 264 [Nm]</p>			
		I			

Displacement	
TYPE	CODE
X3T/15	66
X3T/18	68
X3T/21	70
X3T/27	72
X3T/32	74
X3T/38	78
X3T/43	79
X3T/47	80
X3T/51	81
X3T/54	82
X3T/61	83
X3T/64	85
X3T/70	86
X3T/74	87
X3T/90	89

Standard bodies				
Displacement cm3/rev	Standard threads			
	15	A - A	D - D	H - H
18	A - A	D - D	H - H	
21	A - A	D - D	H - H	
27	A - A	E - E	H - H	
32	B - B	E - E	H - H	
38	B - B	E - E	H - H	
43	B - B	E - E	H - H	
47	B - B	E - E	H - H	
51	B - B	E - E	H - H	
54	B - B	E - E	H - H	
61	C - C	F - F		
64	C - C	F - F		
70	C - C	F - F		
74	C - C	F - F		
90	C - C	F - F		

Table showing standard flange and thread combinations available in stock

Body (threads/flanges)													
	A		B		C		D		E		F		G
	H		I		L		M		N		O		P
Closed Body	Z												

entrainment pump - series XV

X3T

"SAE B" DRIVING PUMP
 ø101.6 FLANGE - SPLINED SHAFT

X 3 T 78 32 I E E A

Series	X	series XV
Group	3	group 3
Category	T	entrainment pump
Displacement	78	38
Flange	32	Ø101.6 SAE B right rotation
Shaft	I	
Body	IN	inlet - 1" BSP
	OUT	outlet - 1" BSP
Cover	A	ø50,8 female cover for left multiple pump element

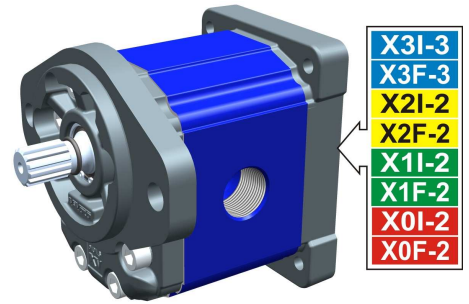

XT331

Technical data table

TYPE	Displacement cm3/rev	Max. Pressure		CODE	
		P1 bar	P3 bar	Left rotation	Right rotation
X3T/15	14,89	300	320	X 3 T 66 31 I D D A	X 3 T 66 32 I D D A
X3T/18	17,37	300	320	X 3 T 68 31 I D D A	X 3 T 68 32 I D D A
X3T/21	21,10	280	300	X 3 T 70 31 I D D A	X 3 T 70 32 I D D A
X3T/27	26,97	250	270	X 3 T 72 31 I E E A	X 3 T 72 32 I E E A
X3T/32	32,27	250	270	X 3 T 74 31 I E E A	X 3 T 74 32 I E E A
X3T/38	38,47	250	270	X 3 T 78 31 I E E A	X 3 T 78 32 I E E A
X3T/43	43,44	250	270	X 3 T 79 31 I E E A	X 3 T 79 32 I E E A
X3T/47	47,16	230	250	X 3 T 80 31 I E E A	X 3 T 80 32 I E E A
X3T/51	50,88	230	250	X 3 T 81 31 I E E A	X 3 T 81 32 I E E A
X3T/54	54,60	230	250	X 3 T 82 31 I E E A	X 3 T 82 32 I E E A
X3T/61	60,81	230	250	X 3 T 83 31 I F F A	X 3 T 83 32 I F F A
X3T/64	64,53	210	230	X 3 T 85 31 I F F A	X 3 T 85 32 I F F A
X3T/70	70,74	200	220	X 3 T 86 31 I F F A	X 3 T 86 32 I F F A
X3T/74	74,46	180	200	X 3 T 87 31 I F F A	X 3 T 87 32 I F F A
X3T/90	86,87	150	170	X 3 T 89 31 I F F A	X 3 T 89 32 I F F A

P1) Max. working pressure - P3) Max. peak pressure

For heavy-duty applications, it is recommended to check the admissible torque of the shaft

Dimensions table

TYPE	Weight	A	B	D	D
	kg	mm	mm	IN	OUT
X3T/15	7,010	122,0	61,0	3/4" BSPP	3/4" BSPP
X3T/18	7,070	124,0	62,0	3/4" BSPP	3/4" BSPP
X3T/21	7,150	127,0	63,5	3/4" BSPP	3/4" BSPP
X3T/27	7,250	131,0	65,5	1" BSPP	1" BSPP
X3T/32	7,390	136,0	68,0	1" BSPP	1" BSPP
X3T/38	7,520	141,0	70,5	1" BSPP	1" BSPP
X3T/43	7,630	145,0	72,5	1" BSPP	1" BSPP
X3T/47	7,710	148,0	74,0	1" BSPP	1" BSPP
X3T/51	7,790	151,0	75,5	1" BSPP	1" BSPP
X3T/54	7,870	154,0	77,0	1" BSPP	1" BSPP
X3T/61	8,010	159,0	79,5	1" 1/4 BSPP	1" 1/4 BSPP
X3T/64	8,090	162,0	81,0	1" 1/4 BSPP	1" 1/4 BSPP
X3T/70	8,220	167,0	83,5	1" 1/4 BSPP	1" 1/4 BSPP
X3T/74	8,300	170,0	85,0	1" 1/4 BSPP	1" 1/4 BSPP
X3T/90	8,570	180,0	90,0	1" 1/4 BSPP	1" 1/4 BSPP

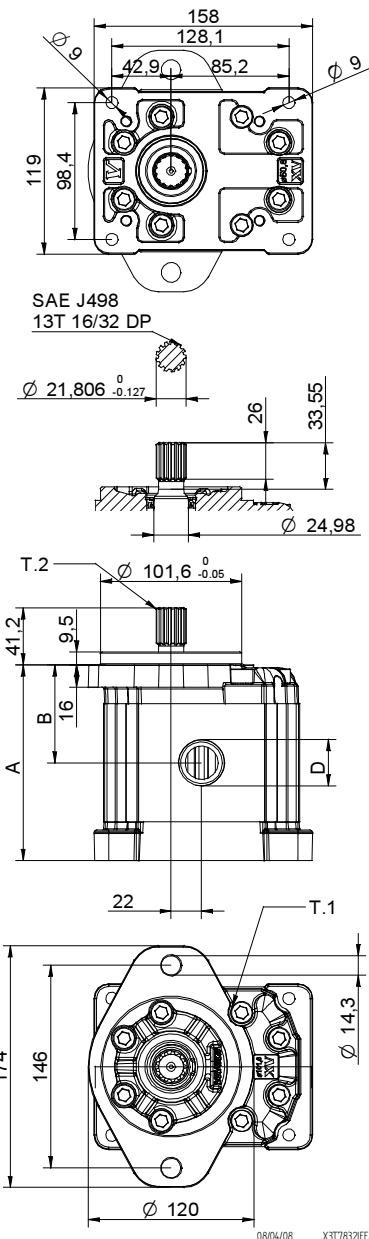

T.1 = 60÷65 [Nm] - screw tightening torque M10

T.2 = 264 [Nm] - admissible shaft torque (N.B. When choosing a shaft, always check the admissible torque).

Table of variations

X3T

∅101.6 FLANGE ""SAE B""

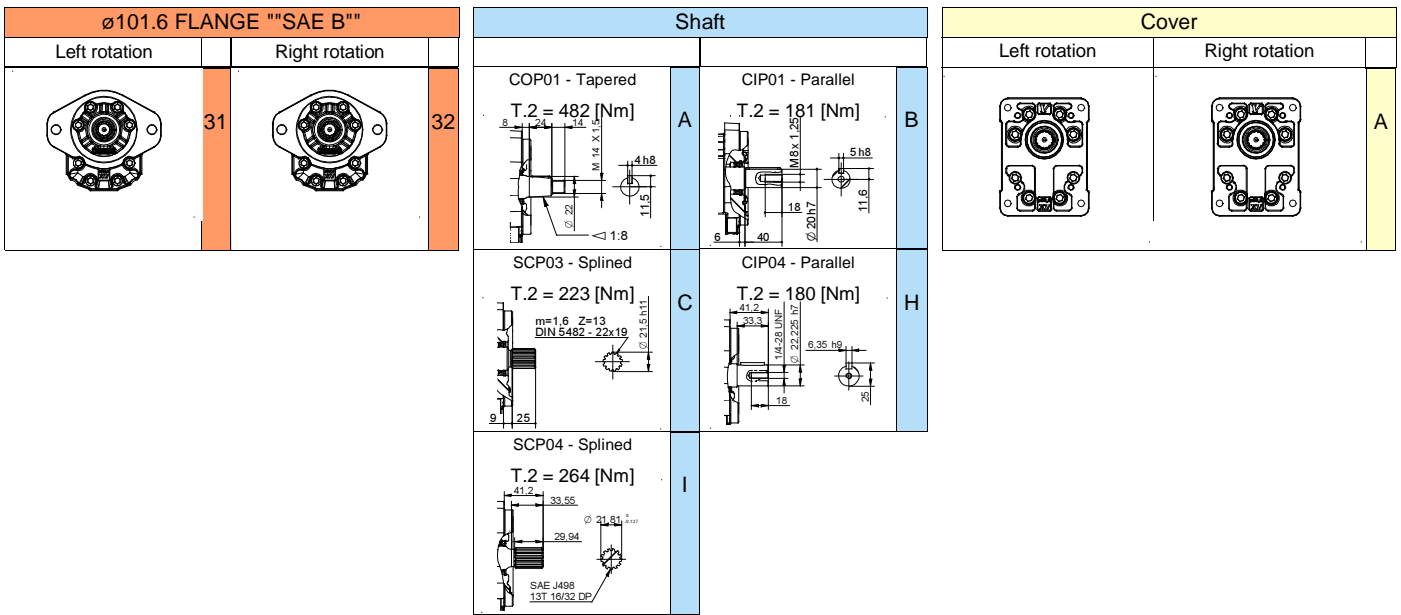

Displacement	
TYPE	CODE
X3T/15	66
X3T/18	68
X3T/21	70
X3T/27	72
X3T/32	74
X3T/38	78
X3T/43	79
X3T/47	80
X3T/51	81
X3T/54	82
X3T/61	83
X3T/64	85
X3T/70	86
X3T/74	87
X3T/90	89

Standard bodies				
Displacement cm3/rev	Standard threads			
	15	A - A	D - D	H - H
18	A - A	D - D	H - H	
21	A - A	D - D	H - H	
27	A - A	E - E	H - H	
32	B - B	E - E	H - H	
38	B - B	E - E	H - H	
43	B - B	E - E	H - H	
47	B - B	E - E	H - H	
51	B - B	E - E	H - H	
54	B - B	E - E	H - H	
61	C - C	F - F		
64	C - C	F - F		
70	C - C	F - F		
74	C - C	F - F		
90	C - C	F - F		

Table showing standard flange and thread combinations available in stock

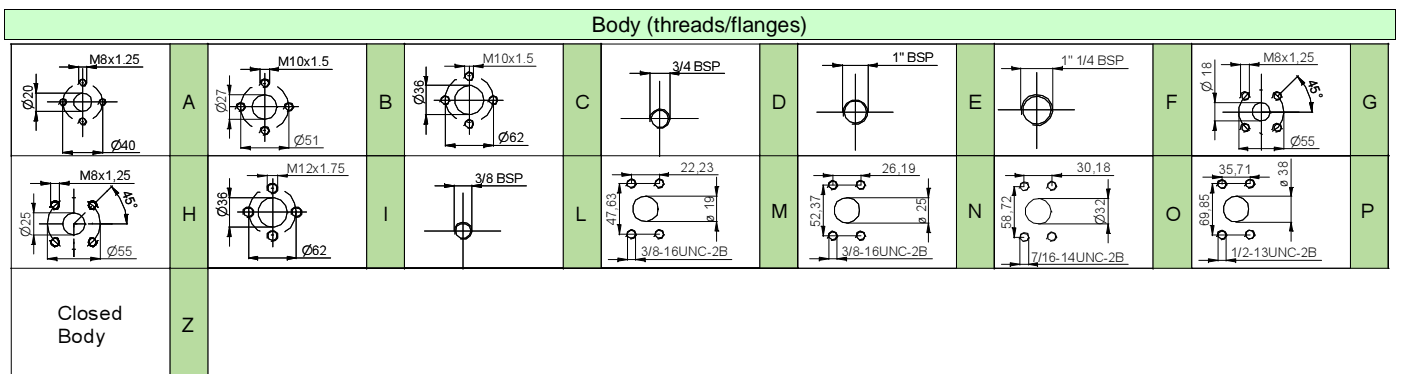

intermediate pump - series XV

X3I-3

STANDARD INTERMEDIATE PUMP
ø50.8 FLANGE - TAPER SHAFT

X 3 I 78 02 D B B A

Series	X	series XV
Group	3	group 3
Category	I	intermediate pump
Displacement	78	38
Flange	02	Ø50.8 female right rotation
Shaft	D	SCI01 - Splined ø24.5 - z=14 H=18 m=1.6 - DIN5482 25x22
Body	IN	inlet - Ø51 Ø27 M10
	OUT	outlet - Ø51 Ø27 M10
Cover	A	ø50,8 female cover for left multiple pump element

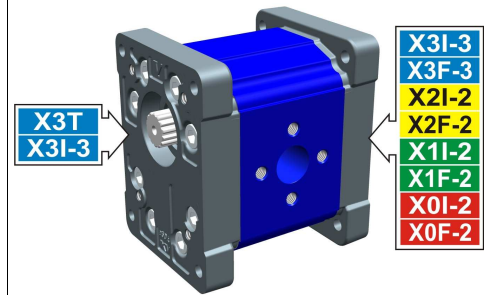

XI301

Technical data table

TYPE	Displacement cm3/rev	Max. Pressure		CODE																	
		P1 bar	P3 bar	Left rotation			Right rotation														
X3I-3/15	14,89	300	320	X	3	I	66	01	D	A	A	A	X	3	I	66	02	D	A	A	A
X3I-3/18	17,37	300	320	X	3	I	68	01	D	A	A	A	X	3	I	68	02	D	A	A	A
X3I-3/21	21,10	280	300	X	3	I	70	01	D	A	A	A	X	3	I	70	02	D	A	A	A
X3I-3/27	26,97	250	270	X	3	I	72	01	D	A	A	A	X	3	I	72	02	D	A	A	A
X3I-3/32	32,27	250	270	X	3	I	74	01	D	B	B	A	X	3	I	74	02	D	B	B	A
X3I-3/38	38,47	250	270	X	3	I	78	01	D	B	B	A	X	3	I	78	02	D	B	B	A
X3I-3/43	43,44	250	270	X	3	I	79	01	D	B	B	A	X	3	I	79	02	D	B	B	A
X3I-3/47	47,16	230	250	X	3	I	80	01	D	B	B	A	X	3	I	80	02	D	B	B	A
X3I-3/51	50,88	230	250	X	3	I	81	01	D	B	B	A	X	3	I	81	02	D	B	B	A
X3I-3/54	54,60	230	250	X	3	I	82	01	D	B	B	A	X	3	I	82	02	D	B	B	A
X3I-3/61	60,81	230	250	X	3	I	83	01	D	C	C	A	X	3	I	83	02	D	C	C	A
X3I-3/64	64,53	210	230	X	3	I	85	01	D	C	C	A	X	3	I	85	02	D	C	C	A
X3I-3/70	70,74	200	220	X	3	I	86	01	D	C	C	A	X	3	I	86	02	D	C	C	A
X3I-3/74	74,46	180	200	X	3	I	87	01	D	C	C	A	X	3	I	87	02	D	C	C	A
X3I-3/90	86,87	150	170	X	3	I	89	01	D	C	C	A	X	3	I	89	02	D	C	C	A

P1) Max. working pressure - P3) Max. peak pressure

For heavy-duty applications, it is recommended to check the admissible torque of the shaft

Dimensions table

TYPE	Weight kg	A	B	D	E	F	D	E	F
		mm	mm	IN			OUT		
X3I-3/15	7,010	122,0	61,0	ø20	40	M8	ø20	40	M8
X3I-3/18	7,070	124,0	62,0	ø20	40	M8	ø20	40	M8
X3I-3/21	7,150	127,0	63,5	ø20	40	M8	ø20	40	M8
X3I-3/27	7,250	131,0	65,5	ø20	40	M8	ø20	40	M8
X3I-3/32	7,390	136,0	68,0	ø27	51	M10	ø27	51	M10
X3I-3/38	7,520	141,0	70,5	ø27	51	M10	ø27	51	M10
X3I-3/43	7,630	145,0	72,5	ø27	51	M10	ø27	51	M10
X3I-3/47	7,710	148,0	74,0	ø27	51	M10	ø27	51	M10
X3I-3/51	7,790	151,0	75,5	ø27	51	M10	ø27	51	M10
X3I-3/54	7,870	154,0	77,0	ø27	51	M10	ø27	51	M10
X3I-3/61	8,010	159,0	79,5	ø36	62	M10	ø36	62	M10
X3I-3/64	8,090	162,0	81,0	ø36	62	M10	ø36	62	M10
X3I-3/70	8,220	167,0	83,5	ø36	62	M10	ø36	62	M10
X3I-3/74	8,300	170,0	85,0	ø36	62	M10	ø36	62	M10
X3I-3/90	8,570	180,0	90,0	ø36	62	M10	ø36	62	M10

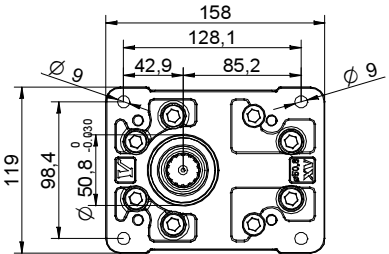
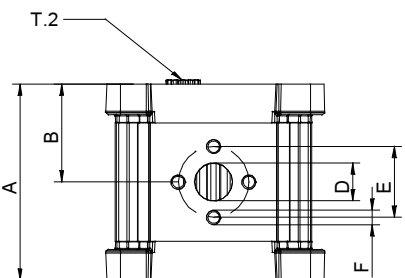
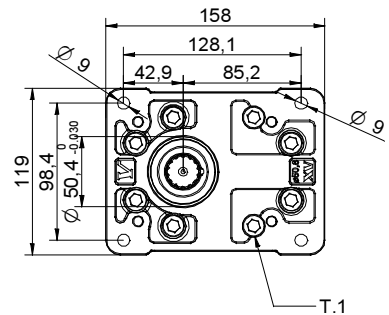

08/04/08 X3I7802DBBA.dft

T.1 = 60÷65 [Nm] - screw tightening torque M10

T.2 = 332 [Nm] - admissible shaft torque (N.B. When choosing a shaft, always check the admissible torque).

Table of variations

X3I-3

Female $\varnothing 50.8$ FLANGE

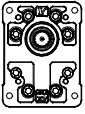
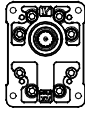
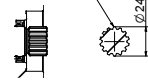
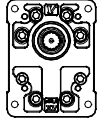
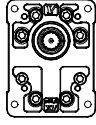
Female $\varnothing 50.8$ FLANGE		Shaft		Cover		
Left rotation	Right rotation			Left rotation	Right rotation	
		SCI01 - Splined T.2 = 332 [Nm] m=1.6 Z=14 DIN 5482 - 25x22 				
	01		02			D
						A

Displacement	
TYPE	CODE
X3I-3/15	66
X3I-3/18	68
X3I-3/21	70
X3I-3/27	72
X3I-3/32	74
X3I-3/38	78
X3I-3/43	79
X3I-3/47	80
X3I-3/51	81
X3I-3/54	82
X3I-3/61	83
X3I-3/64	85
X3I-3/70	86
X3I-3/74	87
X3I-3/90	89

Standard bodies				
Displacement cm3/rev	Standard threads			
	15	A - A	D - D	H - H
18	A - A	D - D	H - H	
21	A - A	D - D	H - H	
27	A - A	E - E	H - H	
32	B - B	E - E	H - H	
38	B - B	E - E	H - H	
43	B - B	E - E	H - H	
47	B - B	E - E	H - H	
51	B - B	E - E	H - H	
54	B - B	E - E	H - H	
61	C - C	F - F		
64	C - C	F - F		
70	C - C	F - F		
74	C - C	F - F		
90	C - C	F - F		

Table showing standard flange and thread combinations available in stock

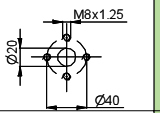
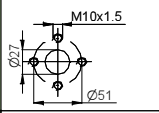
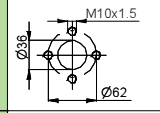
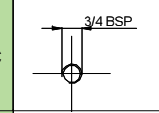
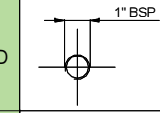
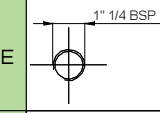
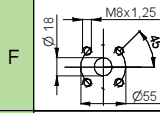
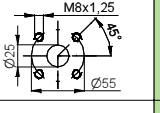
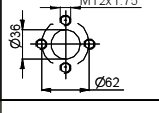
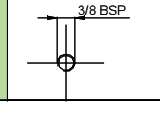
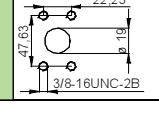
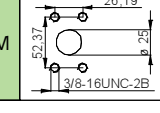
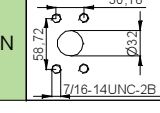
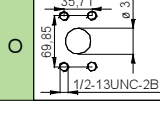
Body (threads/flanges)													
	A		B		C		D		E		F		G
	H		I		L		M		N		O		P
Closed Body	Z												

final pump - series XV

X3F-3

STANDARD FINAL PUMP
ø50.8 FLANGE - TAPER SHAFT

X 3 F 78 02 D B B A

Series	X	series XV
Group	3	group 3
Category	F	final pump
Displacement	78	38
Flange	02	Ø50.8 female right rotation
Shaft	D	SCF01 - Splined ø24.5 - z=14 H=18 m=1.6 - DIN5482 25x22
Body	IN	inlet - Ø51 Ø27 M10
	OUT	outlet - Ø51 Ø27 M10
Cover	A	standard

X3T
X3I-3

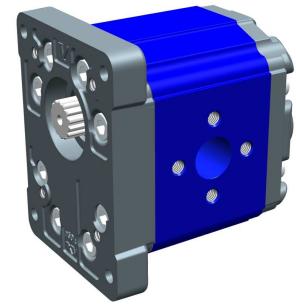

XF301

Technical data table

TYPE	Displacement cm3/rev	Max. Pressure		CODE																	
		P1 bar	P3 bar	Left rotation			Right rotation														
X3F-3/15	14,89	300	320	X	3	F	66	01	D	A	A	A	X	3	F	66	02	D	A	A	A
X3F-3/18	17,37	300	320	X	3	F	68	01	D	A	A	A	X	3	F	68	02	D	A	A	A
X3F-3/21	21,10	280	300	X	3	F	70	01	D	A	A	A	X	3	F	70	02	D	A	A	A
X3F-3/27	26,97	250	270	X	3	F	72	01	D	A	A	A	X	3	F	72	02	D	A	A	A
X3F-3/32	32,27	250	270	X	3	F	74	01	D	B	B	A	X	3	F	74	02	D	B	B	A
X3F-3/38	38,47	250	270	X	3	F	78	01	D	B	B	A	X	3	F	78	02	D	B	B	A
X3F-3/43	43,44	250	270	X	3	F	79	01	D	B	B	A	X	3	F	79	02	D	B	B	A
X3F-3/47	47,16	230	250	X	3	F	80	01	D	B	B	A	X	3	F	80	02	D	B	B	A
X3F-3/51	50,88	230	250	X	3	F	81	01	D	B	B	A	X	3	F	81	02	D	B	B	A
X3F-3/54	54,60	230	250	X	3	F	82	01	D	B	B	A	X	3	F	82	02	D	B	B	A
X3F-3/61	60,81	230	250	X	3	F	83	01	D	C	C	A	X	3	F	83	02	D	C	C	A
X3F-3/64	64,53	210	230	X	3	F	85	01	D	C	C	A	X	3	F	85	02	D	C	C	A
X3F-3/70	70,74	200	220	X	3	F	86	01	D	C	C	A	X	3	F	86	02	D	C	C	A
X3F-3/74	74,46	180	200	X	3	F	87	01	D	C	C	A	X	3	F	87	02	D	C	C	A
X3F-3/90	86,87	150	170	X	3	F	89	01	D	C	C	A	X	3	F	89	02	D	C	C	A

P1) Max. working pressure - P3) Max. peak pressure

For heavy-duty applications, it is recommended to check the admissible torque of the shaft

Dimensions table

TYPE	Weight kg	A	B	D	E	F	D	E	F
		mm	mm	IN			OUT		
X3F-3/15	7,010	124,0	61,0	ø20	40	M8	ø20	40	M8
X3F-3/18	7,070	126,0	62,0	ø20	40	M8	ø20	40	M8
X3F-3/21	7,150	129,0	63,5	ø20	40	M8	ø20	40	M8
X3F-3/27	7,250	133,0	65,5	ø20	40	M8	ø20	40	M8
X3F-3/32	7,390	138,0	68,0	ø27	51	M10	ø27	51	M10
X3F-3/38	7,520	143,0	70,5	ø27	51	M10	ø27	51	M10
X3F-3/43	7,630	147,0	72,5	ø27	51	M10	ø27	51	M10
X3F-3/47	7,710	150,0	74,0	ø27	51	M10	ø27	51	M10
X3F-3/51	7,790	153,0	75,5	ø27	51	M10	ø27	51	M10
X3F-3/54	7,870	156,0	77,0	ø27	51	M10	ø27	51	M10
X3F-3/61	8,010	161,0	79,5	ø36	62	M10	ø36	62	M10
X3F-3/64	8,090	164,0	81,0	ø36	62	M10	ø36	62	M10
X3F-3/70	8,220	169,0	83,5	ø36	62	M10	ø36	62	M10
X3F-3/74	8,300	172,0	85,0	ø36	62	M10	ø36	62	M10
X3F-3/90	8,570	182,0	90,0	ø36	62	M10	ø36	62	M10

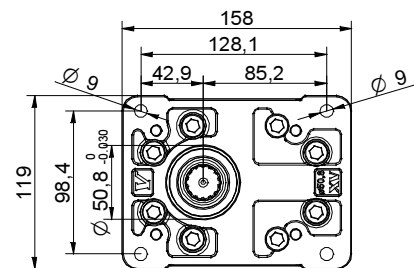
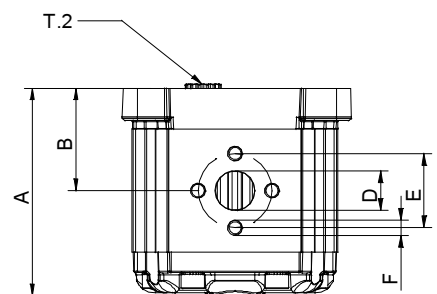
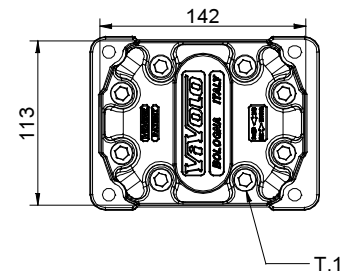

09/04/08 X3F78020B8A.dft

T.1 = 60÷65 [Nm] - screw tightening torque M10

T.2 = 332 [Nm] - admissible shaft torque (N.B. When choosing a shaft, always check the admissible torque).

Table of variations

X3F-3

Female $\varnothing 50.8$ FLANGE

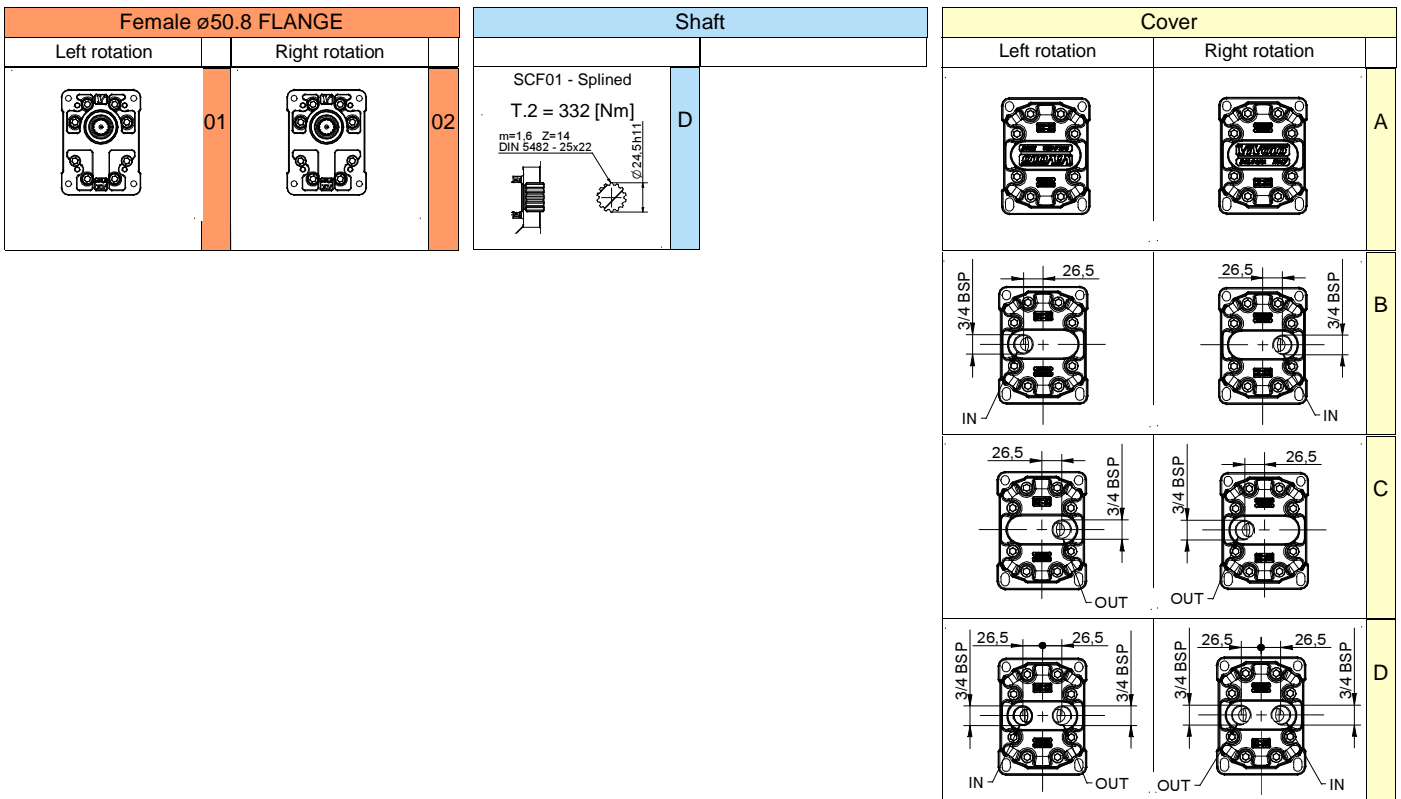

Displacement	
TYPE	CODE
X3F-3/15	66
X3F-3/18	68
X3F-3/21	70
X3F-3/27	72
X3F-3/32	74
X3F-3/38	78
X3F-3/43	79
X3F-3/47	80
X3F-3/51	81
X3F-3/54	82
X3F-3/61	83
X3F-3/64	85
X3F-3/70	86
X3F-3/74	87
X3F-3/90	89

Standard bodies				
Displacement cm3/rev	Standard threads			
	15	A - A	D - D	H - H
18	A - A	D - D	H - H	
21	A - A	D - D	H - H	
27	A - A	E - E	H - H	
32	B - B	E - E	H - H	
38	B - B	E - E	H - H	
43	B - B	E - E	H - H	
47	B - B	E - E	H - H	
51	B - B	E - E	H - H	
54	B - B	E - E	H - H	
61	C - C	F - F		
64	C - C	F - F		
70	C - C	F - F		
74	C - C	F - F		
90	C - C	F - F		

Table showing standard flange and thread combinations available in stock

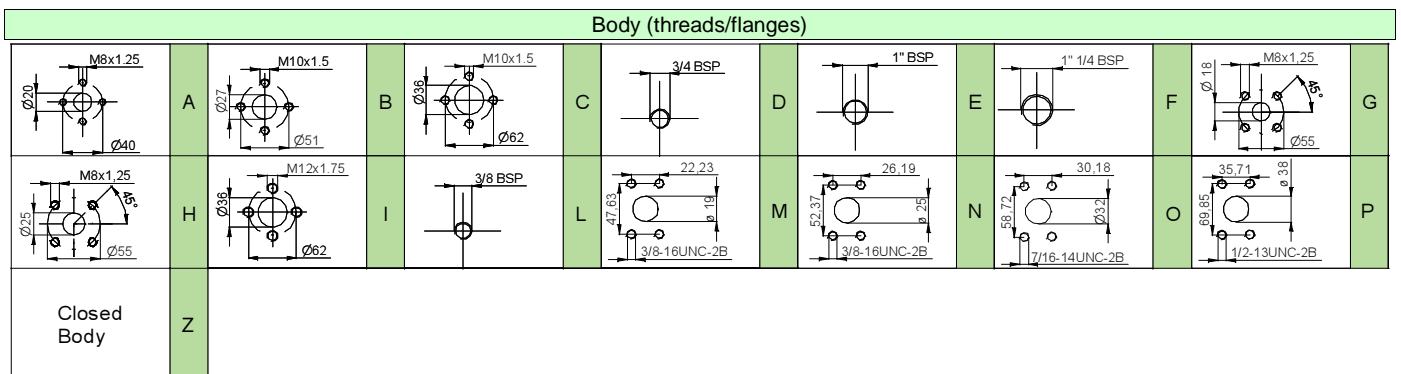



DOUBLE SHAFT - Variant VA

All versions may be supplied with a double shaft using all types of shafts and flanges
As per catalogue

Example of order code

Standard -----X0P0602ABBA
With double shaft -----X0P0602ABBA **VA**

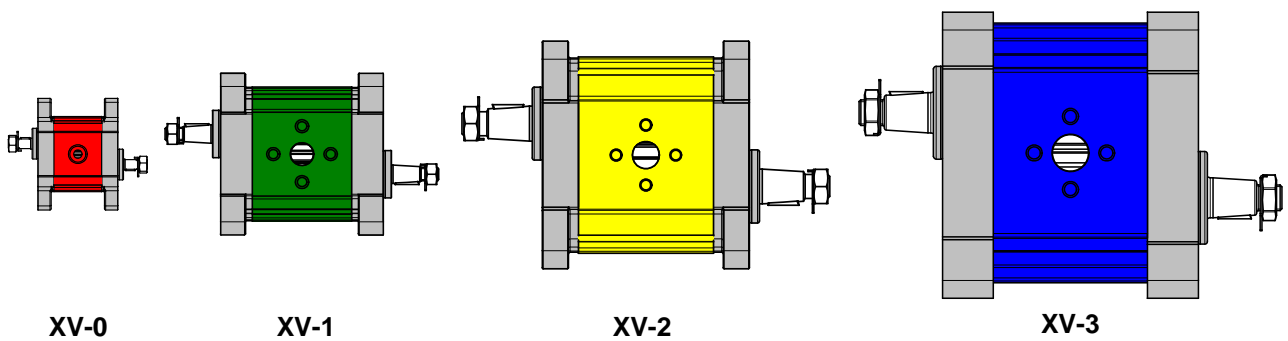

SEALS made of FKM (viton) variant VITON

All versions may be supplied with **FKM (viton)** seals

Example of order code

Standard-----X0P0602ABBA
With FKM (viton) seals -----X0P0602ABBA **VITON**

O-RINGS

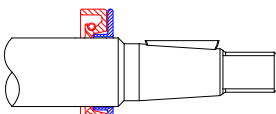
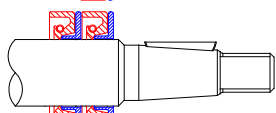
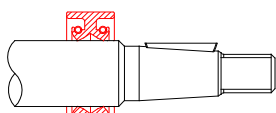
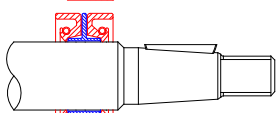
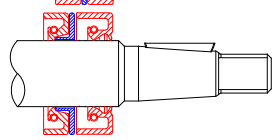
Variant VDC		Oil seal with backup washer (standard for motors)
Variant VDCX		Double oil seal with double backup washer
Variant VDB		DUPLEX oil seal
Variant VDBX		Double opposed oil seal with backup washer
Variant VDCO		Motor Oil Seal with backup washer + Standard Oil Seal

Example of order code

Standard-----X1P0602FIIA
With oil seal and retaining washer -----X1P0602FIIA **VDC**

Pressure-relief valve VM25 for XV0 series

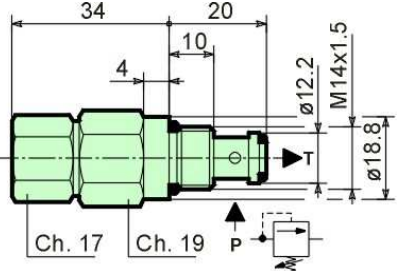
	Technical specifications	
	Capacity	25 l/min
	Max pressure in P	315 bars
	Max pressure in T	315 bars
	Setting range of spring Type 01	20-140 bars
	Setting range of spring Type 02	70-315 bars
	Required filtration	10-15 µm
	Oil viscosity range	2.8-350 cSt
	Recommended oil temperature	-20 + 80 °C
	Seal material	Buna N
	Weight	0.110 kg
	Pressures with flow of 1 l/min: opening value in relation to setting	95%
	Closing value in relation to setting	75%
	Hydraulic oil	HM, HV ISO 6074

Pressure-relief valve VM50 for XV1 and XV2 series

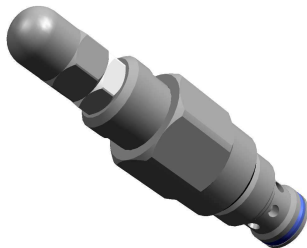
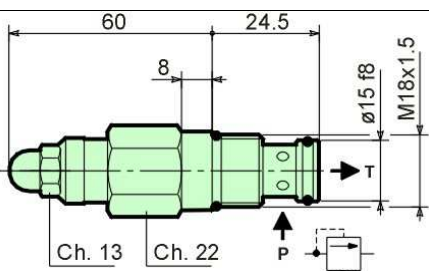
	Technical specifications	
	Capacity	50/min
	Max pressure in P	350 bars
	Max pressure in T	350 bars
	Setting range of spring Type 01	10-105 bars
	Setting range of spring Type 02	70-210 bars
	Setting range of spring Type 03	140-350 bars
	Required filtration	10-15 µm
	Oil viscosity range	2.8-350 cSt
	Recommended oil temperature	-20 + 80 °C
	Seal material	Buna N
	Weight	0.125 kg
	Pressures with flow of 1 l/min: opening value in relation to setting	95%
	Closing value in relation to setting	75%
	Hydraulic oil	HM, HV ISO 6074

Standard test settings

TYPE	Pressure (bars)	Capacity (l/min)	Pressure increase (bars x turn of screw)
1 (10-105 bars)	50	5	15
2 (70-210 bars)	130	5	32
3 (140-350 bars)	200	5	67

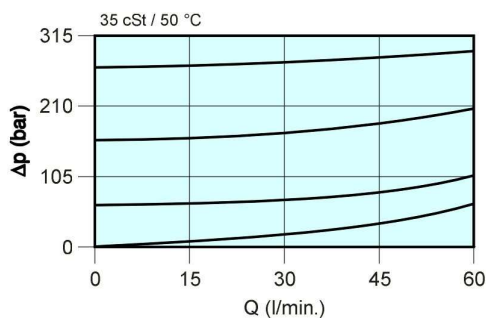

Performance of VM25 and VM50 valves

Δp = Pressure drop in bars

Q = Capacity in litres per minute

90° STEEL ELBOWS

Code	Type	A	B	C	D	E	F	G	OR	V	weigth
									O ring	Screw	
8KRG001	RG 26/12-3/8"BSP	3/8"	26	5,5	12	18	9,5	27	ø14,00x1,78	M5x18	0,13
8KRG002	RG 26/12-1/2"BSP	1/2"	26	5,5	12	18	9,5	27	ø14,00x1,78	M5x18	0,12
8KRG003	RG 30/13,5 -3/8"BSP	3/8"	30	6,5	13,5	18	9,5	27	ø15,88x2,62	M6x20	0,17
8KRG004	RG 30/13,5 -1/2"BSP	1/2"	30	6,5	13,5	18	9,5	27	ø15,88x2,62	M6x20	0,16
8KRG005	RG 40/20-1/2"BSP	1/2"	40	8,5	20	21	10,5	38	ø23,81x2,62	M8x25	0,36
8KRG006	RG 40/20-3/4"BSP	3/4"	40	8,5	20	21	10,5	38	ø23,81x2,62	M8x25	0,32
8KRG007	RG 40/23-3/4"BSP	3/4"	40	8,5	23,5	21	10,5	38	ø25,12x1,78	M8x25	0,29
8KRG008	RG 51/27-1"BSP	1"	51	10,5	27	27	13,5	47	ø31,42x2,62	M10x30	0,7
8KRG009	RG 51/27-3/4" BSP	3/4"	51	10,5	27	27	13,5	47	ø31,42x2,62	M10x30	0,7
8KRG011	RG 56/34-3/4" BSP	3/4"	56	10,5	34	27	13,5	47	ø37,77x2,62	M10x30	0,72
8KRG012	RG 62/36-1"1/4 BSP	1"1/4	62	10,5	36	36	19	56	ø41,28x3,53	M10x30	0,94
8KRG015	RG 62/36-1"1/4 BSP M12	1"1/4	62	12,5	36	36	19	56	ø41,28x3,53	M12x35	0,94
8KRG013	RG 72,5/45-1"1/2 BSP	1"1/2	72,5	12,5	45	38	16	58	ø49,20x3,53	M12x35	1,23
8KRG014	RG 92/65-2" BSP	2	92	12,5	65	50	21	75	ø69,85x3,53	M12x40	1,65

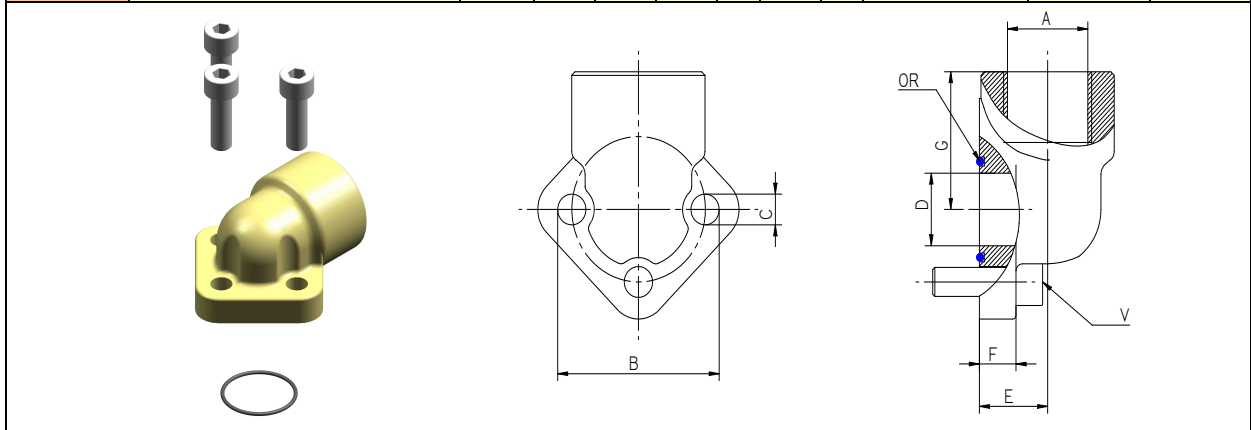

STRAIGHT STEEL UNIONS

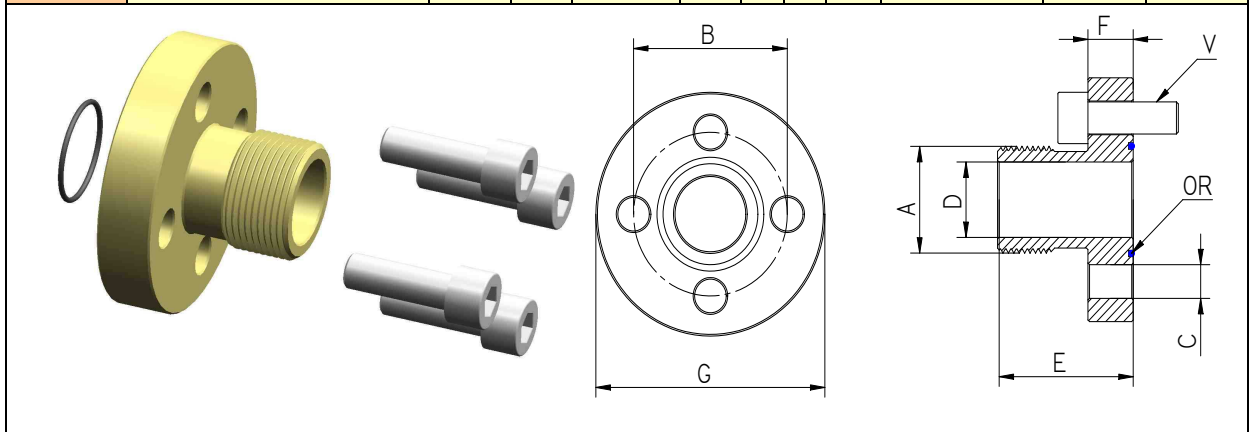
Code	Type	A	B	C	D	E	F	G	OR	V	Weigth
									O ring	Screw	
8KRD001	RD 26/12-3/8"BSP	3/8"	26	5,5	12	32	10	39	ø14,00x1,78	M5x18	0,11
8KRD002	RD 30/13,5-1/2"BSP	1/2"	30	6,5	13,5	40	10	44	ø15,88x2,62	M6x20	0,14
8KRD005	RD 40/20-3/4"BSP	3/4"	40	8,5	20	42	12	51	ø23,81x2,62	M8x25	0,3
8KRD006	RD 40/23,5-3/4"BSP	3/4"	40	8,5	23,5	42	12	51	ø25,12x1,78	M8x25	0,29
8KRD007	RD 51/27-1"BSP	1"	51	10,5	27	43	12	68	ø31,42x2,62	M10x25	0,46
8KRD008	RD 56/34-1"1/4 BSP	1" 1/4	56	10,5	34	53	12	73	ø37,77x2,62	M10x25	0,68
8KRD009	RD 62/36-1"1/4 BSP	1" 1/4	62	10,5	36	47	13	78	ø41,28x3,53	M10x25	0,9
8KRD010	RD 72,5/45-1"1/2 BSP	1" 1/2	72,5	12,5	45	49	14	89	ø49,20x3,53	M12x30	1,05
8KRD011	RD 92/65-2"1/2 BSP	2" 1/2	92	12,5	65	60	18	114	ø69,85x3,53	M12x40	1,15

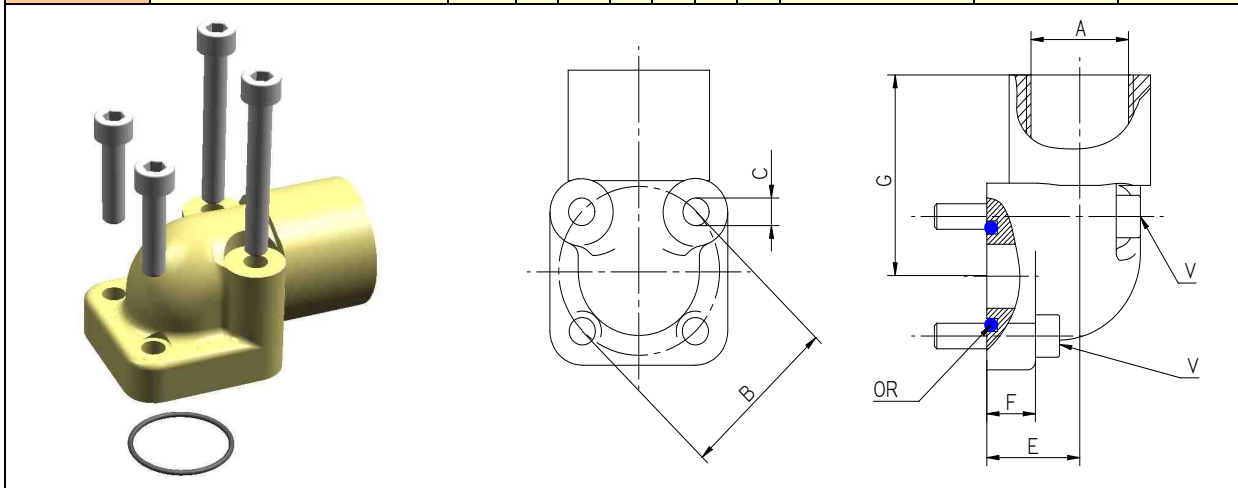

SQUARED STEEL ELBOWS

Code	Type	A	B	C	D	E	F	G	OR	V	Weight
									O ring	Screw	
8KRQ001	RQ 30/12-3/8"BSP	3/8"	30	6,5	12	19	11	41	ø15,88x2,61	Nº2 M6x20 Nº2 M6x35	0,29
8KRQ002	RQ 30/12-1/2"BSP	1/2"	30	6,5	12	19	11	41	ø15,88x2,62	Nº2 M6x20 Nº2 M6x35	0,29
8KRQ003	RQ 35/15 -3/8"BSP	3/8"	35	6,5	15	18	11	40	ø18,72x2,62	Nº2 M6x20 Nº2 M6x35	0,34
8KRQ004	RQ 35/15 -1/2"BSP	1/2"	35	6,5	15	18	11	40	ø18,72x2,62	Nº2 M6x20 Nº2 M6x35	0,34
8KRQ005	RQ 40/20-1/2"BSP	1/2"	40	6,5	20	24	10	45	ø22,22x2,62	Nº2 M6x25 Nº2 M6x45	0,4
8KRQ006	RQ 40/20-3/4"BSP	3/4"	40	6,5	20	24	10	45	ø22,22x2,62	Nº2 M6x25 Nº2 M6x45	0,4
8KRQ007	RQ 55/25-3/4"BSP	3/4"	55	8,5	25	35	13	54	ø29,75x3,53	Nº2 M8x25 Nº2 M8x60	0,45
8KRQ008	RQ 55/25-1" BSP	1"	55	8,5	25	35	13	54	ø29,75x3,53	Nº2 M8x25 Nº2 M8x60	0,45

STRAIGHT STEEL UNIONS

Code	Type	A	B	C	D	E	F	G	OR	V	Weight
									O ring	Screw	
8KRD003	RD 35/15 (BH)-1/2"BSP	1/2"	35	6,5	14	35	10	40	ø18,72x2,62	M6x20	0,15
8KRD004	RD 40/20 (BH)-3/4"BSP	3/4"	40	6,5	17	35	10	40	ø22,22x2,62	M6x20	0,17

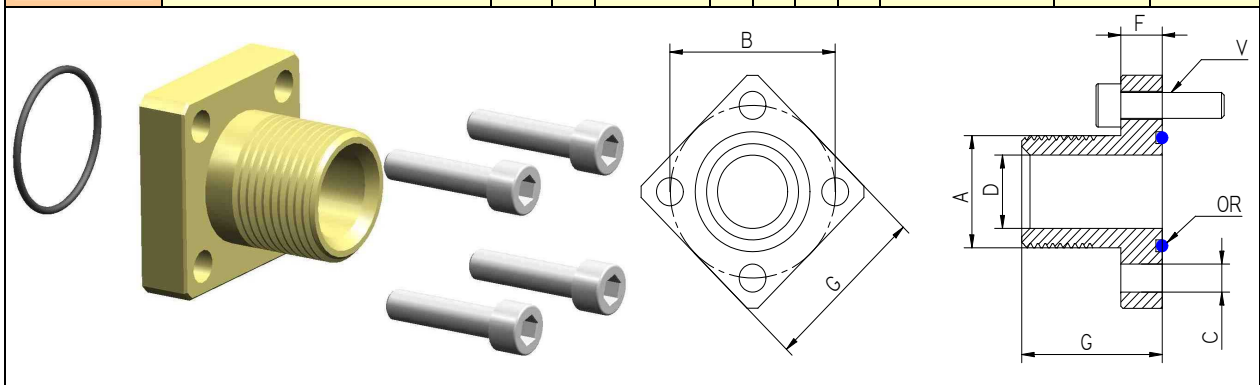

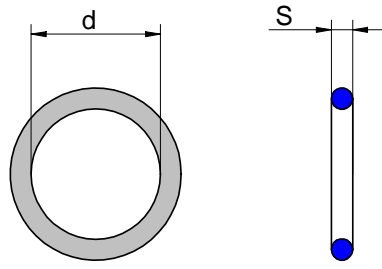
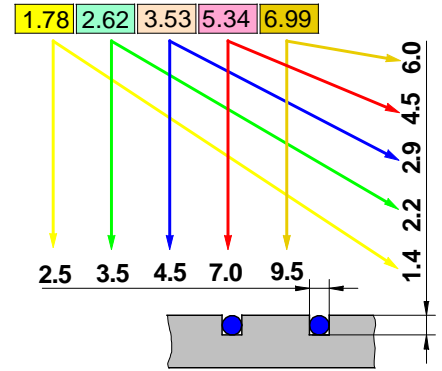
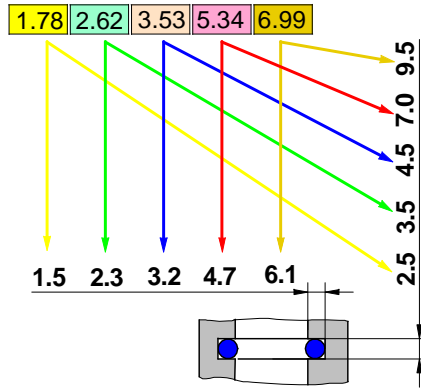
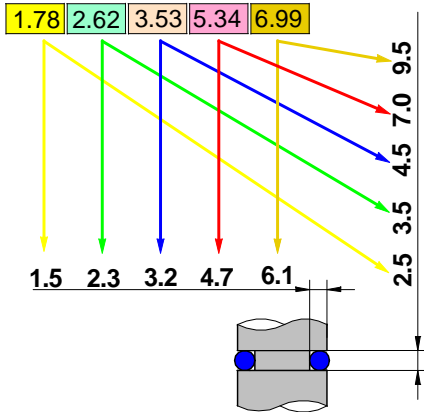

S=1,78		S=2,62				S=3,53				S=5,34				S=6,99		
1,78	33,05	9,13	34,60	82,22	247,33	18,64	52,39	88,50	190,1	37,43	107,2	158,12	481,46	113,7	181,0	342,3
2,57	34,65	9,19	36,14	88,57		20,22	53,37	91,67	196,4	40,65	109,5	164,47	506,86	114,7	183,5	354,9
2,90	37,82	9,92	37,77	94,92		21,82	53,98	94,84	202,8	43,82	110,5	170,82	532,26	116,8	187,3	367,7
3,68	41,00	10,78	39,34	101,27		23,40	55,56	98,02	209,1	47,00	113,7	117,17	557,66	120,0	189,9	380,3
4,47	44,17	11,91	40,95	107,63		24,99	56,74	101,2	215,5	50,16	116,84	183,52	582,68	123,2	193,7	393,1
5,28	47,35	12,37	42,52	113,98		25,80	57,15	104,4	221,8	53,34	117,5	189,87	608,08	124,6	196,2	
6,07	50,52	13,10	44,12	120,33		26,58	58,74	107,5	228,2	56,52	120,02	196,22	633,48	126,4	200,0	
6,75	53,70	13,95	45,69	126,67		28,17	59,92	110,7	234,5	59,69	120,7	202,57	658,88	129,5	202,6	
7,65	56,87	15,08	47,30	133,00		29,75	60,33	113,9	240,9	62,87	123,2	208,92		132,7	208,9	
8,73	60,05	15,54	48,99	139,38		31,34	61,91	117,1	247,2	66,04	123,8	215,27		134,5	215,3	
9,25	63,22	15,88	50,47	145,73		32,93	63,09	120,2	253,6	69,22	126,37	221,62		135,9	221,6	
10,82	66,40	17,13	52,07	152,07		34,52	63,50	123,4	266,3	72,39	127,0	227,97		139,1	227,9	
11,11	69,57	17,86	53,65	158,43		36,10	56,09	126,6	279,0	74,63	129,54	234,32		142,2	234,3	
12,42	72,75	18,72	55,25	164,78		37,89	66,27	129,8	291,7	75,57	130,2	240,67		145,4	240,7	
14,00	75,92	20,29	56,82	171,13		39,69	66,68	132,9	304,4	78,74	132,72	247,02		148,6	247,0	
15,60	82,27	20,63	58,42	177,48		40,89	68,26	136,1	329,8	79,77	133,4	253,37		151,8	253,3	
17,17	88,62	21,89	60,00	183,83		41,28	69,44	139,3	355,2	81,92	135,9	266,07		155,6	259,7	
18,77	94,97	22,22	61,60	190,18		42,86	69,85	142,5	380,6	85,09	136,5	278,77		158,1	266,1	
20,35	101,32	23,47	63,17	196,53		44,04	71,44	145,6	405,2	88,27	139,07	291,5		159,5	272,4	
31,95	107,67	23,81	64,77	202,88		44,45	72,62	148,8	430,6	89,69	139,7	304,17		161,9	278,7	
23,52	114,02	25,07	66,35	209,23		46,04	73,03	152,0	456,0	91,44	142,9	329,57		164,5	285,1	
25,12	120,37	26,65	67,95	215,58		47,22	74,61	158,3		94,62	145,42	354,97		166,7	291,5	
26,70	126,72	28,25	69,52	221,93		47,63	75,80	164,7		97,79	146,1	380,37		168,3	297,8	
28,30	133,07	29,82	71,12	228,28		49,21	78,97	171,0		100,0	148,6	405,26		170,8	304,1	
29,87		31,42	72,69	234,63		50,39	82,14	177,4		101,0	149,2	430,66		174,6	316,9	
31,47		32,99	75,87	240,98		50,80	85,32	183,7		104,1	151,77	456,06		177,2	329,6	



Table of oil speeds

Speed m/sec		Capacities - l/min																			
		5	10	15	20	25	30	35	40	45	50	55	60	65	70	75	80	85	90	95	100
Inlet	0,5	14,6	20,6	25,2	29,1	32,6	35,7	38,5	41,2	43,7	46,0	48,3	50,4	52,5	54,5	56,4	58,2	60,0	61,8	63,5	65,1
	1,0	10,3	14,6	17,8	20,6	23,0	25,2	27,2	29,1	30,9	32,6	34,1	35,7	37,1	38,5	39,9	41,2	42,4	43,7	44,9	46,0
	1,3	9,2	13,0	15,9	18,4	20,6	22,6	24,4	26,0	27,6	29,1	30,5	31,9	33,2	34,5	35,7	36,8	38,0	39,1	40,1	41,2
	1,5	8,4	11,9	14,6	16,8	18,8	20,6	22,2	23,8	25,2	26,6	27,9	29,1	30,3	31,5	32,6	33,6	34,7	35,7	36,6	37,6
Return	1,8	7,8	11,0	13,5	15,6	17,4	19,1	20,6	22,0	23,3	24,6	25,8	27,0	28,1	29,1	30,1	31,1	32,1	33,0	33,9	34,8
	2,0	7,3	10,3	12,6	14,6	16,3	17,8	19,3	20,6	21,8	23,0	24,1	25,2	26,2	27,2	28,2	29,1	30,0	30,9	31,7	32,6
	2,5	6,5	9,2	11,3	13,0	14,6	15,9	17,2	18,4	19,5	20,6	21,6	22,6	23,5	24,4	25,2	26,0	26,8	27,6	28,4	29,1
Outlet	3,0	5,9	8,4	10,3	11,9	13,3	14,6	15,7	16,8	17,8	18,8	19,7	20,6	21,4	22,2	23,0	23,8	24,5	25,2	25,9	26,6
	3,5	5,5	7,8	9,5	11,0	12,3	13,5	14,6	15,6	16,5	17,4	18,3	19,1	19,8	20,6	21,3	22,0	22,7	23,3	24,0	24,6
	4,0	5,1	7,3	8,9	10,3	11,5	12,6	13,6	14,6	15,4	16,3	17,1	17,8	18,6	19,3	19,9	20,6	21,2	21,8	22,4	23,0
	4,5	4,9	6,9	8,4	9,7	10,9	11,9	12,8	13,7	14,6	15,3	16,1	16,8	17,5	18,2	18,8	19,4	20,0	20,6	21,2	21,7
	5,0	4,6	6,5	8,0	9,2	10,3	11,3	12,2	13,0	13,8	14,6	15,3	15,9	16,6	17,2	17,8	18,4	19,0	19,5	20,1	20,6
	5,5	4,4	6,2	7,6	8,8	9,8	10,8	11,6	12,4	13,2	13,9	14,6	15,2	15,8	16,4	17,0	17,6	18,1	18,6	19,1	19,6
	6,0	4,2	5,9	7,3	8,4	9,4	10,3	11,1	11,9	12,6	13,3	13,9	14,6	15,2	15,7	16,3	16,8	17,3	17,8	18,3	18,8
	6,5	4,0	5,7	7,0	8,1	9,0	9,9	10,7	11,4	12,1	12,8	13,4	14,0	14,6	15,1	15,6	16,2	16,7	17,1	17,6	18,1
	7,0	3,9	5,5	6,7	7,8	8,7	9,5	10,3	11,0	11,7	12,3	12,9	13,5	14,0	14,6	15,1	15,6	16,0	16,5	17,0	17,4
	7,5	3,8	5,3	6,5	7,5	8,4	9,2	9,9	10,6	11,3	11,9	12,5	13,0	13,6	14,1	14,6	15,0	15,5	15,9	16,4	16,8
	8,0	3,6	5,1	6,3	7,3	8,1	8,9	9,6	10,3	10,9	11,5	12,1	12,6	13,1	13,6	14,1	14,6	15,0	15,4	15,9	16,3
	8,5	3,5	5,0	6,1	7,1	7,9	8,7	9,3	10,0	10,6	11,2	11,7	12,2	12,7	13,2	13,7	14,1	14,6	15,0	15,4	15,8
	9,0	3,4	4,9	5,9	6,9	7,7	8,4	9,1	9,7	10,3	10,9	11,4	11,9	12,4	12,8	13,3	13,7	14,1	14,6	15,0	15,3
	9,5	3,3	4,7	5,8	6,7	7,5	8,2	8,8	9,4	10,0	10,6	11,1	11,6	12,0	12,5	12,9	13,4	13,8	14,2	14,6	14,9
	10,0	3,3	4,6	5,6	6,5	7,3	8,0	8,6	9,2	9,8	10,3	10,8	11,3	11,7	12,2	12,6	13,0	13,4	13,8	14,2	14,6
Speed m/sec	Inner pipe diameter - mm																				

Speed m/sec		Capacities - l/min																			
		110	120	130	140	150	160	170	180	190	200	210	220	230	240	250	260	270	280	290	300
Inlet	0,5	68,3	71,3	74,2	77,0	79,7	82,4	84,9	87,4	89,8	92,1	94,4	96,6	98,8	100,9	103,0	105,0	107,0	109,0	110,9	112,8
	1,0	48,3	50,4	52,5	54,5	56,4	58,2	60,0	61,8	63,5	65,1	66,7	68,3	69,8	71,3	72,8	74,2	75,7	77,0	78,4	79,7
	1,3	43,2	45,1	47,0	48,7	50,4	52,1	53,7	55,3	56,8	58,2	59,7	61,1	62,5	63,8	65,1	66,4	67,7	68,9	70,1	71,3
	1,5	39,4	41,2	42,9	44,5	46,0	47,6	49,0	50,4	51,8	53,2	54,5	55,8	57,0	58,2	59,4	60,6	61,8	62,9	64,0	65,1
Return	1,8	36,5	38,1	39,7	41,2	42,6	44,0	45,4	46,7	48,0	49,2	50,4	51,6	52,8	53,9	55,0	56,1	57,2	58,2	59,3	60,3
	2,0	34,1	35,7	37,1	38,5	39,9	41,2	42,4	43,7	44,9	46,0	47,2	48,3	49,4	50,4	51,5	52,5	53,5	54,5	55,4	56,4
	2,5	30,5	31,9	33,2	34,5	35,7	36,8	38,0	39,1	40,1	41,2	42,2	43,2	44,2	45,1	46,0	47,0	47,8	48,7	49,6	50,4
Outlet	3,0	27,9	29,1	30,3	31,5	32,6	33,6	34,7	35,7	36,6	37,6	38,5	39,4	40,3	41,2	42,0	42,9	43,7	44,5	45,3	46,0
	3,5	25,8	27,0	28,1	29,1	30,1	31,1	32,1	33,0	33,9	34,8	35,7	36,5	37,3	38,1	38,9	39,7	40,4	41,2	41,9	42,6
	4,0	24,1	25,2	26,2	27,2	28,2	29,1	30,0	30,9	31,7	32,6	33,4	34,1	34,9	35,7	36,4	37,1	37,8	38,5	39,2	39,9
	4,5	22,8	23,8	24,7	25,7	26,6	27,5	28,3	29,1	29,9	30,7	31,5	32,2	32,9	33,6	34,3	35,0	35,7	36,3	37,0	37,6
	5,0	21,6	22,6	23,5	24,4	25,2	26,0	26,8	27,6	28,4	29,1	29,8	30,5	31,2	31,9	32,6	33,2	33,8	34,5	35,1	35,7
	5,5	20,6	21,5	22,4	23,2	24,0	24,8	25,6	26,3	27,1	27,8	28,5	29,1	29,8	30,4	31,0	31,7	32,3	32,9	33,4	34,0
	6,0	19,7	20,6	21,4	22,2	23,0	23,8	24,5	25,2	25,9	26,6	27,2	27,9	28,5	29,1	29,7	30,3	30,9	31,5	32,0	32,6
	6,5	18,9	19,8	20,6	21,4	22,1	22,8	23,5	24,2	24,9	25,5	26,2	26,8	27,4	28,0	28,6	29,1	29,7	30,2	30,8	31,3
	7,0	18,3	19,1	19,8	20,6	21,3	22,0	22,7	23,3	24,0	24,6	25,2	25,8	26,4	27,0	27,5	28,1	28,6	29,1	29,6	30,1
	7,5	17,6	18,4	19,2	19,9	20,6	21,3	21,9	22,6	23,2	23,8	24,4	24,9	25,5	26,0	26,6	27,1	27,6	28,1	28,6	29,1
	8,0	17,1	17,8	18,6	19,3	19,9	20,6	21,2	21,8	22,4	23,0	23,6	24,1	24,7	25,2	25,7	26,2	26,7	27,2	27,7	28,2
	8,5	16,6	17,3	18,0	18,7	19,3	20,0	20,6	21,2	21,8	22,3	22,9	23,4	24,0	24,5	25,0	25,5	26,0	26,4	26,9	27,4
	9,0	16,1	16,8	17,5	18,2	18,8	19,4	20,0	20,6	21,2	21,7	22,2	22,8	23,3	23,8	24,3	24,7	25,2	25,7	26,1	26,6
	9,5	15,7	16,4	17,0	17,7	18,3	18,9	19,5	20,0	20,6	21,1	21,6	22,2	22,7	23,1	23,6	24,1	24,5	25,0	25,4	25,9
	10,0	15,3	15,9	16,6	17,2	17,8	18,4	19,0	19,5	20,1	20,6	21,1	21,6	22,1	22,6	23,0	23,5	23,9	24,4	24,8	25,2
Speed m/sec	Inner pipe diameter - mm																				

Speed m/sec	Capacities - l/min																				
	320	340	360	380	400	420	440	460	480	500	520	540	560	580	600	620	640	660	680	700	
Inlet	0,5	116,5	120,1	123,5	126,9	130,2	133,4	136,6	139,7	142,7	145,6	148,5	151,3	154,1	156,8	159,5	162,1	164,7	167,3	169,8	172,3
	1,0	82,4	84,9	87,4	89,8	92,1	94,4	96,6	98,8	100,9	103,0	105,0	107,0	109,0	110,9	112,8	114,6	116,5	118,3	120,1	121,8
	1,3	73,7	75,9	78,1	80,3	82,4	84,4	86,4	88,3	90,2	92,1	93,9	95,7	97,5	99,2	100,9	102,5	104,2	105,8	107,4	109,0
	1,5	67,3	69,3	71,3	73,3	75,2	77,0	78,9	80,6	82,4	84,1	85,7	87,4	89,0	90,5	92,1	93,6	95,1	96,6	98,0	99,5
Return	1,8	62,3	64,2	66,0	67,8	69,6	71,3	73,0	74,6	76,3	77,8	79,4	80,9	82,4	83,8	85,3	86,7	88,1	89,4	90,8	92,1
	2,0	58,2	60,0	61,8	63,5	65,1	66,7	68,3	69,8	71,3	72,8	74,2	75,7	77,0	78,4	79,7	81,1	82,4	83,6	84,9	86,1
	2,5	52,1	53,7	55,3	56,8	58,2	59,7	61,1	62,5	63,8	65,1	66,4	67,7	68,9	70,1	71,3	72,5	73,7	74,8	75,9	77,0
Outlet	3,0	47,6	49,0	50,4	51,8	53,2	54,5	55,8	57,0	58,2	59,4	60,6	61,8	62,9	64,0	65,1	66,2	67,3	68,3	69,3	70,3
	3,5	44,0	45,4	46,7	48,0	49,2	50,4	51,6	52,8	53,9	55,0	56,1	57,2	58,2	59,3	60,3	61,3	62,3	63,2	64,2	65,1
	4,0	41,2	42,4	43,7	44,9	46,0	47,2	48,3	49,4	50,4	51,5	52,5	53,5	54,5	55,4	56,4	57,3	58,2	59,1	60,0	60,9
	4,5	38,8	40,0	41,2	42,3	43,4	44,5	45,5	46,6	47,6	48,5	49,5	50,4	51,4	52,3	53,2	54,0	54,9	55,8	56,6	57,4
	5,0	36,8	38,0	39,1	40,1	41,2	42,2	43,2	44,2	45,1	46,0	47,0	47,8	48,7	49,6	50,4	51,3	52,1	52,9	53,7	54,5
	5,5	35,1	36,2	37,3	38,3	39,3	40,2	41,2	42,1	43,0	43,9	44,8	45,6	46,5	47,3	48,1	48,9	49,7	50,4	51,2	51,9
	6,0	33,6	34,7	35,7	36,6	37,6	38,5	39,4	40,3	41,2	42,0	42,9	43,7	44,5	45,3	46,0	46,8	47,6	48,3	49,0	49,7
	6,5	32,3	33,3	34,3	35,2	36,1	37,0	37,9	38,7	39,6	40,4	41,2	42,0	42,7	43,5	44,2	45,0	45,7	46,4	47,1	47,8
	7,0	31,1	32,1	33,0	33,9	34,8	35,7	36,5	37,3	38,1	38,9	39,7	40,4	41,2	41,9	42,6	43,3	44,0	44,7	45,4	46,0
	7,5	30,1	31,0	31,9	32,8	33,6	34,5	35,3	36,1	36,8	37,6	38,3	39,1	39,8	40,5	41,2	41,9	42,5	43,2	43,8	44,5
	8,0	29,1	30,0	30,9	31,7	32,6	33,4	34,1	34,9	35,7	36,4	37,1	37,8	38,5	39,2	39,9	40,5	41,2	41,8	42,4	43,1
	8,5	28,3	29,1	30,0	30,8	31,6	32,4	33,1	33,9	34,6	35,3	36,0	36,7	37,4	38,0	38,7	39,3	40,0	40,6	41,2	41,8
	9,0	27,5	28,3	29,1	29,9	30,7	31,5	32,2	32,9	33,6	34,3	35,0	35,7	36,3	37,0	37,6	38,2	38,8	39,4	40,0	40,6
9,5	26,7	27,5	28,3	29,1	29,9	30,6	31,3	32,0	32,7	33,4	34,1	34,7	35,4	36,0	36,6	37,2	37,8	38,4	39,0	39,5	
10,0	26,0	26,8	27,6	28,4	29,1	29,8	30,5	31,2	31,9	32,6	33,2	33,8	34,5	35,1	35,7	36,3	36,8	37,4	38,0	38,5	
Speed m/sec	Inner pipe diameter - mm																				

$d =$ Inner pipe diameter [mm]	$d = \sqrt{\frac{Q \cdot 21.2}{V}} [mm] \quad V = \frac{Q \cdot 21.2}{d^2} [m/sec] \quad Q = \frac{d^2 \cdot V}{21.2} [l/min]$
$Q =$ Capacities [l]	
$V =$ Speed [m/sec]	

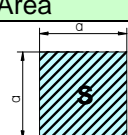
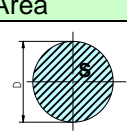
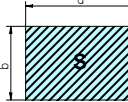
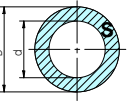
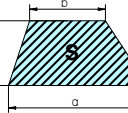
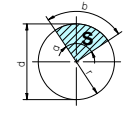
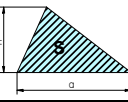
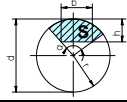
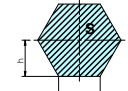
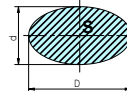
Table of Areas and Perimeters			
S= Area	S= Area	S= Area	
	$S = a^2$ $P = a \times 4$		$S = \pi/4 \times D^2$ $P = \pi \times D$
	$S = a \times b$ $P = 2(a + b)$		$S = \pi/4 \times (D^2 - d^2)$
	$S = (a + b) \times h/2$		$S = \pi \times r^2 \times \alpha / 360^\circ$ $b = \pi \times \alpha \times r / 360^\circ$
	$S = a \times h/2$		$S = (\pi r^2 \alpha / 360^\circ) - (b \times (r - h) / 2)$
	$S = 3 \times a \times h$		$S = \pi/4 \times D \times d$



Pressure conversion table

Mpa	bar	Kg/cm ²	PSI	bar	Mpa	Kg/cm ²	PSI	Kg/cm ²	Mpa	bar	PSI	PSI	Mpa	bar	Kg/cm ²
1	10	10,19	145,14	1	0,1	1,019	14,5	1	0,902	0,981	14,22	1	0,007	0,069	0,0703
2	20	20,38	290,28	2	0,2	2,038	29	2	1,902	1,962	28,44	2	0,014	0,138	0,1406
3	30	30,57	435,42	3	0,3	3,057	43,5	3	2,902	2,943	42,66	3	0,021	0,207	0,2109
4	40	40,76	580,56	4	0,4	4,076	58	4	3,902	3,924	56,88	4	0,028	0,276	0,2812
5	50	50,95	725,7	5	0,5	5,095	72,5	5	4,902	4,905	71,1	5	0,035	0,345	0,3515
6	60	61,14	870,84	6	0,6	6,114	87	6	5,902	5,886	85,32	6	0,042	0,414	0,4218
7	70	71,33	1016	7	0,7	7,133	101,5	7	6,902	6,867	99,54	7	0,049	0,483	0,4921
8	80	81,52	1161,1	8	0,8	8,152	116	8	7,902	7,848	113,76	8	0,056	0,552	0,5624
9	90	91,71	1306,3	9	0,9	9,171	130,5	9	8,902	8,829	127,98	9	0,063	0,621	0,6327
10	100	101,9	1451,4	10	1	10,19	145	10	9,902	9,81	142,2	10	0,07	0,69	0,703
20	200	203,8	2902,8	20	2	20,38	290	20	19,902	19,62	284,4	20	0,14	1,38	1,406
30	300	305,7	4354,2	30	3	30,57	435	30	29,902	29,43	426,6	30	0,21	2,07	2,109
40	400	407,6	5805,6	40	4	40,76	580	40	39,902	39,24	568,8	40	0,28	2,76	2,812
50	500	509,5	7257	50	5	50,95	725	50	49,902	49,05	711	50	0,35	3,45	3,515
60	600	611,4	8708,4	60	6	61,14	870	60	59,902	58,86	853,2	60	0,42	4,14	4,218
70	700	713,3	10160	70	7	71,33	1015	70	69,902	68,67	995,4	70	0,49	4,83	4,921
80	800	815,2	11611	80	8	81,52	1160	80	79,902	78,48	1137,6	80	0,56	5,52	5,624
90	900	917,1	13063	90	9	91,71	1305	90	89,902	88,29	1279,8	90	0,63	6,21	6,327
100	1000	1019	14514	100	10	101,9	1450	100	99,902	98,1	1422	100	0,7	6,9	7,03
110	1100	1120,9	15965	110	11	112,09	1595	110	109,9	107,91	1564,2	110	0,77	7,59	7,733
120	1200	1222,8	17417	120	12	122,28	1740	120	119,9	117,72	1706,4	120	0,84	8,28	8,436
130	1300	1324,7	18868	130	13	132,47	1885	130	129,9	127,53	1848,6	130	0,91	8,97	9,139
140	1400	1426,6	20320	140	14	142,66	2030	140	139,9	137,34	1990,8	140	0,98	9,66	9,842
150	1500	1528,5	21771	150	15	152,85	2175	150	149,9	147,15	2133	150	1,05	10,35	10,545
160	1600	1630,4	23222	160	16	163,04	2320	160	159,9	156,96	2275,2	160	1,12	11,04	11,248
170	1700	1732,3	24674	170	17	173,23	2465	170	169,9	166,77	2417,4	170	1,19	11,73	11,951
180	1800	1834,2	26125	180	18	183,42	2610	180	179,9	176,58	2559,6	180	1,26	12,42	12,654
190	1900	1936,1	27577	190	19	193,61	2755	190	189,9	186,39	2701,8	190	1,33	13,11	13,357
200	2000	2038	29028	200	20	203,8	2900	200	199,9	196,2	2844	200	1,4	13,8	14,06
210	2100	2139,9	30479	210	21	213,99	3045	210	209,9	206,01	2986,2	210	1,47	14,49	14,763
220	2200	2241,8	31931	220	22	224,18	3190	220	219,9	215,82	3128,4	220	1,54	15,18	15,466
230	2300	2343,7	33382	230	23	234,37	3335	230	229,9	225,63	3270,6	230	1,61	15,87	16,169
240	2400	2445,6	34834	240	24	244,56	3480	240	239,9	235,44	3412,8	240	1,68	16,56	16,872
250	2500	2547,5	36285	250	25	254,75	3625	250	249,9	245,25	3555	250	1,75	17,25	17,575
260	2600	2649,4	37736	260	26	264,94	3770	260	259,9	255,06	3697,2	260	1,82	17,94	18,278
270	2700	2751,3	39188	270	27	275,13	3915	270	269,9	264,87	3839,4	270	1,89	18,63	18,981
280	2800	2853,2	40639	280	28	285,32	4060	280	279,9	274,68	3981,6	280	1,96	19,32	19,684
290	2900	2955,1	42091	290	29	295,51	4205	290	289,9	284,49	4123,8	290	2,03	20,01	20,387
300	3000	3057	43542	300	30	305,7	4350	300	299,9	294,3	4266	300	2,1	20,7	21,09
310	3100	3158,9	44993	310	31	315,89	4495	310	309,9	304,11	4408,2	310	2,17	21,39	21,793
320	3200	3260,8	46445	320	32	326,08	4640	320	319,9	313,92	4550,4	320	2,24	22,08	22,496
330	3300	3362,7	47896	330	33	336,27	4785	330	329,9	323,73	4692,6	330	2,31	22,77	23,199
340	3400	3464,6	49348	340	34	346,46	4930	340	339,9	333,54	4834,8	340	2,38	23,46	23,902
350	3500	3566,5	50799	350	35	356,65	5075	350	349,9	343,35	4977	350	2,45	24,15	24,605
Mpa= 0,1 bar Mpa= 0,098 Kg/cm ² Mpa= 0,007 PSI				bar= 10 MPa bar= 0,981 Kg/cm ² bar= 0,069 PSI				Kg/cm ² = 10,19 MPa Kg/cm ² = 1,019 bar Kg/cm ² = 0,0703 PSI				PSI= 145,14 MPa PSI= 14,5 bar PSI= 14,22 kg/cm ²			



Conversion table

Inches -> Millimetres 1Poll. = 25,40 mm							
in	mm	in	mm	in	mm	in	mm
1/64	0,397	1 1/2	38,1	15	381	36	914,4
1/32	0,764	1 3/4	44,45	16	406,4	38	965,2
3/64	1,191	2	50,8	17	431,8	40	1016
1/16	1,588	2 1/2	63,5	18	457,2	42	1066,8
3/32	2,381	3	76,2	19	482,6	44	1117,6
1/8	3,175	3 1/2	88,9	20	508	46	1168,4
5/32	3,969	4	101,6	21	533,4	48	1219,2
3/16	4,763	4 1/2	114,3	22	558,8	50	1270
1/4	6,35	5	127	23	584,2	55	1397
5/16	7,938	6	152,4	24	609,6	60	1524
3/8	9,525	7	177,8	25	635	65	1651
7/16	11,11	8	203,2	26	660,4	70	1778
1/2	12,7	9	228,6	27	685,8	75	1905
5/8	15,88	10	254	28	711,2	80	2032
3/4	19,05	11	279,4	29	736,6	85	2159
7/8	22,23	12	304,8	30	762	90	2286
1	25,4	13	330,2	32	812,8	95	2413
1 1/4	31,75	14	355,6	34	863,6	100	2540

Millimetres -> Inches 1 mm = 0,03937008 pollici							
mm	in	mm	in	mm	in	mm	in
1	0,039	28	1,102	130	5,12	750	29,53
2	0,079	30	1,181	140	5,51	800	31,50
3	0,118	35	1,378	150	5,91	850	33,46
4	0,157	40	1,575	160	6,30	900	35,43
5	0,197	45	1,772	170	6,69	950	37,40
6	0,236	50	1,969	180	7,09	1000	39,37
7	0,276	55	2,165	190	7,48	1250	49,21
8	0,315	60	2,362	200	7,87	1500	59,06
9	0,354	65	2,559	250	9,84	1750	68,90
10	0,394	70	2,756	300	11,81	2000	78,74
11	0,433	75	2,953	350	13,78	2500	98,43
12	0,472	80	3,150	400	15,75	3000	118,11
14	0,551	85	3,346	450	17,72	3500	137,80
16	0,630	90	3,543	500	19,69	4000	157,48
18	0,709	95	3,740	550	21,65	4500	177,17
20	0,787	100	3,937	600	23,62	5000	196,85
22	0,866	110	4,331	650	25,59	7500	295,28
26	1,024	120	4,724	700	27,56	10000	393,70

US Gallons -> Litres 1gallone = 3,785334 litri							
gal.	litri	gal.	litri	gal.	litri	gal.	litri
1	3,79	10	37,85	100	378,5	500	1893
2	7,57	20	75,71	120	454,2	600	2271
3	11,36	30	113,6	140	529,9	700	2650
4	15,14	40	151,4	160	605,7	800	3028
5	18,93	50	189,3	180	681,4	900	3407
6	22,71	60	227,1	200	757,1	1000	3785
7	26,50	70	265,0	250	946,3	1500	5678
8	30,28	80	302,8	300	1136	2000	7571
9	34,07	90	340,7	400	1514	3000	11356

Litres -> US Gallons 1litro = 0,2641775 galloni							
litri	gal.	litri	gal.	litri	gal.	litri	gal.
1	0,264	10	2,642	300	79,25	3000	792,5
2	0,528	20	5,284	400	105,7	4000	1057
3	0,793	30	7,925	500	132,1	5000	1321
4	1,057	40	10,57	600	158,5	6000	1585
5	1,321	50	13,21	700	184,9	8000	2113
6	1,585	100	26,42	800	211,3	10000	2642
7	1,849	150	39,63	900	237,8	20000	5284
8	2,113	200	52,84	1000	264,2	30000	7925
9	2,378	250	66,04	2000	528,4	50000	13209

Horsepower => Kilowatts 1 CV = 0,735 kW							
CV	Kw	CV	Kw	CV	Kw	CV	Kw
1	0,74	9	6,62	24	17,64	60	44,10
2	1,47	10	7,35	26	19,11	70	51,45
3	2,21	12	8,82	28	20,58	80	58,80
4	2,94	14	10,29	30	22,05	90	66,15
5	3,68	16	11,76	35	25,73	100	73,50
6	4,41	18	13,23	40	29,40	150	110,25
7	5,15	20	14,70	45	33,08	200	147,00
8	5,88	22	16,17	50	36,75	300	220,50

Kilowatts=>Horsepower 1 kW = 1,36 CV							
Kw	CV	Kw	CV	Kw	CV	Kw	CV
1	1,36	9	12,24	24	32,64	60	81,6
2	2,72	10	13,6	26	35,36	70	95,2
3	4,08	12	16,32	28	38,08	80	108,8
4	5,44	14	19,04	30	40,8	90	122,4
5	6,8	16	21,76	35	47,6	100	136
6	8,16	18	24,48	40	54,4	150	204
7	9,52	20	27,2	45	61,2	200	272
8	10,88	22	29,92	50	68	300	408



Table of oil viscosity according to temperature

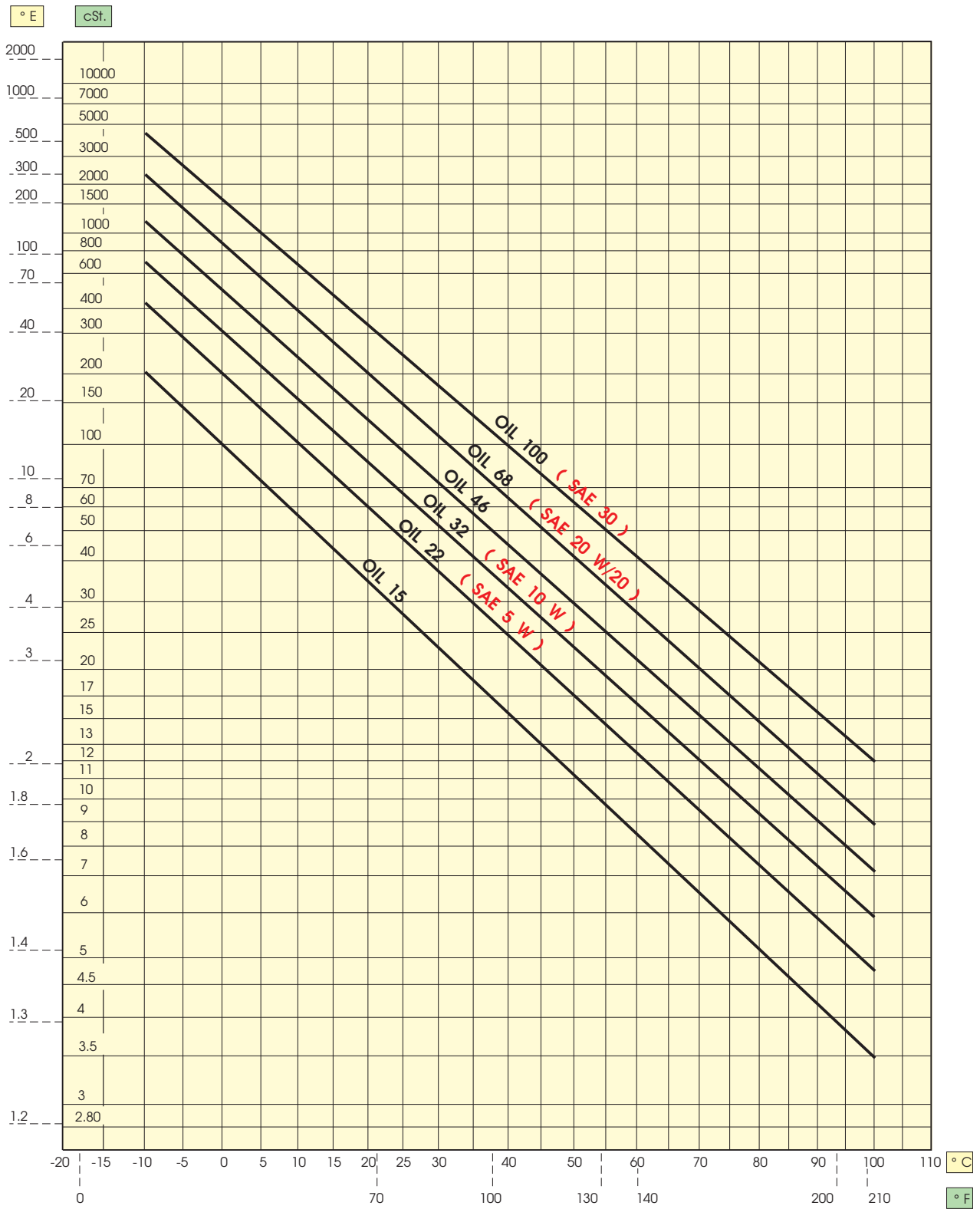



Table of pressure drops

Note: based on the oil viscosity and capacity of a pump it is possible to determine the pressure drop for every 100 m of piping by means of the table.

On the viscosity, flow rate and internal pipe diameter scales, fix the corresponding values **V**, **Q** and **D**.

Join points **V** and **Q** with a straight line intersecting point **I** on the "index" line.

From this point **I**, pass a straight line through **D** until meeting the pressure drop scale at point **P**; the corresponding value represents the pressure drop at point **P**; the corresponding value represents the pressure drop along 100 m of piping.

EXAMPLE: a pipe through which a fluid having a viscosity of 150 cSt. flows at a rate of 200 l/min and which has a diameter of 40 mm will have a pressure drop of 1 kg/cm² for every 100 m of length.

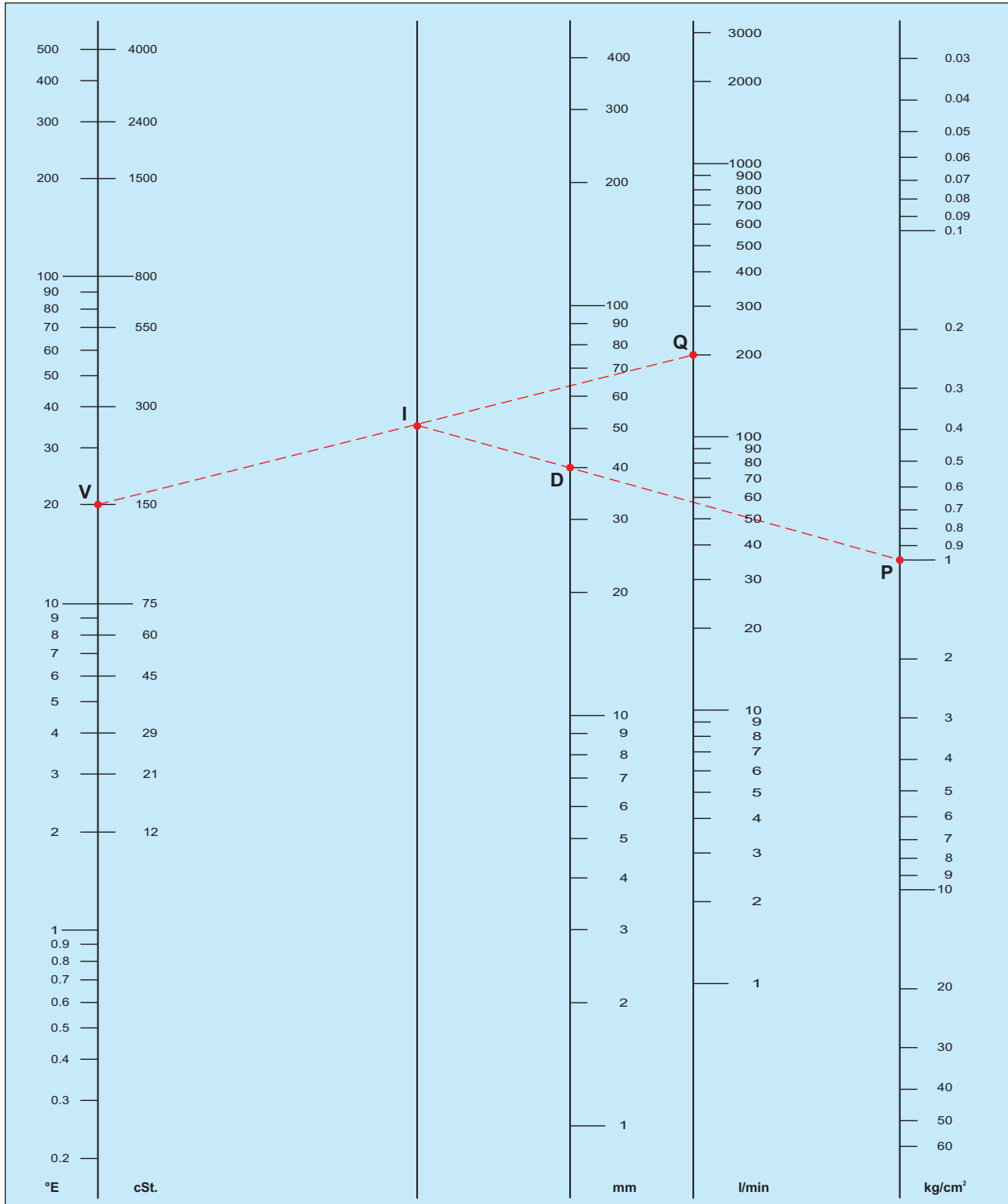

V= Viscosity cSt -°E

I= Index line of intersection

D= Internal pipe diameter in mm

Q= Flow rate in l/min

P= Pressure drop kg/cm² per 100 m

Table of elements

Element	Symbol	Atomic N°	Atom. Wgt.	Melt. point °C
Hafnium	Hf	72	178,49	2150,00
Aluminium	Al	13	26,98	660,37
Americium	Am	95	243,00	994,00
Antimony	Sb	51	121,75	630,00
Silver	Ag	47	107,87	961,93
Argon	Ar	18	39,95	-189,30
Arsenic	As	33	74,92	817,00
Astetina	At	85	210,00	302,00
Actinium	Ac	89	227,00	1050,00
Nitrogen	N	7	14,01	-209,90
Barium	Ba	56	137,33	725,00
Beryllium	Be	4	9,01	1278,00
Berkelium	Bk	97	247,00	
Bismuth	Bi	83	208,98	271,30
Boron	B	5	10,81	2300,00
Bromine	Br	35	79,90	-7,20
Cadmium	Cd	48	112,41	320,90
Calcium	Ca	20	40,08	839,00
Californium	Cf	98	251,00	
Carbon	C	6	12,01	3500,00
Cerium	Ce	58	140,12	795,00
Cesium	Cs	55	132,91	28,50
Chlorine	Cl	17	35,45	-100,98
Cobalt	Co	27	58,93	1495,00
Krypton	Kr	36	83,80	-157,20
Chromium	Cr	24	52,00	1857,00
Curium	Cm	96	247,00	1340,00
Dysprosium	Dy	66	162,50	1412,00
Einsteinium	Es	99	254,00	
Helium	He	2	4,00	-272,00
Erbium	Er	68	167,26	1522,00
Europium	Eu	63	151,96	822,00
Fermium	Fm	100	257,00	
Iron	Fe	26	55,85	1535,00

Element	Symbol	Atomic N°	Atom. Wgt.	Melt. point °C
Fluorine	F	9	19,00	-219,62
Phosphorus	P	15	30,97	44,10
Francium	Fr	87	223,00	27,00
Gadolinium	Gd	64	157,25	1311,00
Gallium	Ga	31	69,74	29,78
Germanium	Ge	32	72,59	937,40
Hydrogen	H	1	1,01	-259,14
Indium	In	49	114,82	156,61
Iodine	I	53	126,90	113,50
Iridium	Ir	77	192,22	2410,00
Ytterbium	Yb	70	173,04	824,00
Yttrium	Y	39	88,91	1523,00
Lanthanum	La	57	138,91	920,00
Lithium	Li	3	6,94	180,54
Lutetium	Lu	71	174,96	1656,00
Magnesium	Mg	12	24,31	638,80
Manganese	Mn	25	54,94	1245,00
Mendelevium	Md	101	258,00	
Mercury	Hg	80	200,59	-38,87
Molybdenum	Mo	42	95,94	2617,00
Neodymium	Nd	60	144,24	1010,00
Neon	Ne	10	20,17	-248,60
Neptunium	Np	93	237,05	640,00
Nickel	Ni	28	58,71	1453,00
Niobium	Nb	41	92,91	2468,00
Nobelium	No	102	259,00	
Holmium	Ho	67	164,93	1470,00
Gold	Au	79	196,97	1064,43
Osmium	Os	76	190,20	3045,00
Oxygen	O	8	16,00	-218,40
Palladium	Pd	46	106,40	1552,00
Lead	Pb	82	207,20	327,50
Platinum	Pt	78	195,09	1772,00
Plutonium	Pu	94	244,00	639,50

Element	Symbol	Atomic N°	Atom. Wgt.	Melt. point °C
Polonium	Po	84	209,00	254,00
Potassium	K	19	39,10	63,65
Praseodymium	Pr	59	140,91	935,00
Promethium	Pm	61	145,00	
Protactinium	Pa	91	231,04	1600,00
Radium	Ra	88	226,03	700,00
Radon	Rn	86	222,00	-71,00
Copper	Cu	29	63,55	1083,00
Rhenium	Re	75	186,21	3180,00
Rhodium	Rh	45	102,91	1966,00
Rubidium	Rb	37	85,47	38,89
Ruthenium	Ru	44	101,07	2250,00
Samarium	Sm	62	150,40	1072,00
Scandium	Sc	21	44,96	1539,00
Selenium	Se	34	78,96	217,00
Silicon	Si	14	28,09	1410,00
Sodium	Na	11	22,99	97,80
Tin	Sn	50	118,69	231,90
Strontium	Sr	38	87,62	769,00
Thallium	Tl	81	204,37	303,50
Tantalum	Ta	73	180,95	2996,00
Technetium	Tc	43	98,91	2200,00
Tellurium	Te	52	127,60	449,50
Terbium	Tb	65	158,93	1360,00
Titanium	Ti	22	47,90	1660,00
Thorium	Th	90	232,04	1750,00
Thulium	Tm	69	168,93	1545,00
Tungsten	W	74	183,85	3410,00
Uranium	U	92	238,03	1132,00
Vanadium	V	23	50,94	1890,00
Xenon	Xe	54	131,30	-111,90
Zinc	Zn	30	65,38	419,58
Zirconium	Zr	40	91,22	1852,00
Sulfur	S	16	32,06	112,80

Specific weight of some substances

SOLIDS	
Aluminium	2,70
Silver	10,50
Diamond	8,51
Pure Iron	7,86
Cast Iron	7,27
Nickel	8,85
Gold	19,33
Brass	8,65
Lead	11,34
Platinum	21,45
Plexiglass	1,18
Copper	8,93

LIQUIDS	
Distilled water	1,00
Ethyl alcohol	0,79
Gasoline	0,68
Mercury	13,60
Linseed Oil	0,93
Petroleum	0,81

GASES	
Acetylene	1,10
Ammonia	0,77
Carbon Dioxide	1,98
Air	1,29
Nitrogen	1,25
Helium	0,18
Ethylene	1,26
Hydrogen	0,09
Methane	0,72
Oxygen	1,43



Table of chemical resistance of elastomers

Class	Behaviour	Effects on Physical Properties	Increase in Volume %	delta Sh.A
●	recommended	small or none	less than 10	less than 10
●	satisfactory	minor	from 10 to 30	from 10 to 20
●	unsatisfactory	moderate	from 30 to 60	from 20 to 30
●	not recommended	severe	greater than 60	greater than 30

- NR** = NATURAL RUBBER
- SBR** = STYRENE-BUTADIENE RUBBER
- EPDM** = ETHYLENE-PROPYLENE THERMOPOLYMER
- NBR** = NITRILE RUBBER
- CR** = POLYCHLOROPRENE
- CSM** = CHLOROSULPHONATED POLYETHYLENE
- VMQ** = SILICONE RUBBER
- FKM** = FLUOROCARBON RUBBER (VITON®)

Acetylene	-	● ● ● ● ● ● ● ●	● ● ● ● ● ● ● ●
Acetophenone	-	● ● ● ● ● ● ● ●	● ● ● ● ● ● ● ●
Acetone	-	● ● ● ● ● ● ● ●	● ● ● ● ● ● ● ●
Acetic Acid	10	● ● ● ● ● ● ● ●	● ● ● ● ● ● ● ●
Acetic Acid	50	● ● ● ● ● ● ● ●	● ● ● ● ● ● ● ●
Acetic Acid	25	● ● ● ● ● ● ● ●	● ● ● ● ● ● ● ●
Acetic Acid	100	● ● ● ● ● ● ● ●	● ● ● ● ● ● ● ●
Boric Acid	10	● ● ● ● ● ● ● ●	● ● ● ● ● ● ● ●
Citric Acid	SAT	● ● ● ● ● ● ● ●	● ● ● ● ● ● ● ●
Chloroacetic Acid	-	● ● ● ● ● ● ● ●	● ● ● ● ● ● ● ●
Chromic Acid	40	● ● ● ● ● ● ● ●	● ● ● ● ● ● ● ●
Formic Acid	SAT.	● ● ● ● ● ● ● ●	● ● ● ● ● ● ● ●
Formic Acid	SAT	● ● ● ● ● ● ● ●	● ● ● ● ● ● ● ●
Phosphoric Acid	60	● ● ● ● ● ● ● ●	● ● ● ● ● ● ● ●
Hypochlorous Acid	-	● ● ● ● ● ● ● ●	● ● ● ● ● ● ● ●
Lactic Acid	-	● ● ● ● ● ● ● ●	● ● ● ● ● ● ● ●
Maleic Acid	-	● ● ● ● ● ● ● ●	● ● ● ● ● ● ● ●
Naphthenic Acid	-	● ● ● ● ● ● ● ●	● ● ● ● ● ● ● ●
Nitric Acid	10	● ● ● ● ● ● ● ●	● ● ● ● ● ● ● ●
Nitric Acid	65	● ● ● ● ● ● ● ●	● ● ● ● ● ● ● ●
Palmitic Acid	-	● ● ● ● ● ● ● ●	● ● ● ● ● ● ● ●
Salicylic Acid	-	● ● ● ● ● ● ● ●	● ● ● ● ● ● ● ●
Stearic Acid	-	● ● ● ● ● ● ● ●	● ● ● ● ● ● ● ●
Sulfhydic Acid	10	● ● ● ● ● ● ● ●	● ● ● ● ● ● ● ●
Sulfhydic Acid	20	● ● ● ● ● ● ● ●	● ● ● ● ● ● ● ●
Sulfuric Acid	25	● ● ● ● ● ● ● ●	● ● ● ● ● ● ● ●
Sulfuric Acid	50	● ● ● ● ● ● ● ●	● ● ● ● ● ● ● ●
Sulfuric Acid	60	● ● ● ● ● ● ● ●	● ● ● ● ● ● ● ●
Sulfuric Acid	75	● ● ● ● ● ● ● ●	● ● ● ● ● ● ● ●
Sulfuric Acid	96	● ● ● ● ● ● ● ●	● ● ● ● ● ● ● ●
Sulfurous Acid	-	● ● ● ● ● ● ● ●	● ● ● ● ● ● ● ●
Tannic Acid	-	● ● ● ● ● ● ● ●	● ● ● ● ● ● ● ●
Tartaric Acid	10	● ● ● ● ● ● ● ●	● ● ● ● ● ● ● ●
Deionized Water	-	● ● ● ● ● ● ● ●	● ● ● ● ● ● ● ●
Turpentine	-	● ● ● ● ● ● ● ●	● ● ● ● ● ● ● ●
Acrylonitrile	-	● ● ● ● ● ● ● ●	● ● ● ● ● ● ● ●
Ammonia	-	● ● ● ● ● ● ● ●	● ● ● ● ● ● ● ●
Aniline	-	● ● ● ● ● ● ● ●	● ● ● ● ● ● ● ●
Aniline	-	● ● ● ● ● ● ● ●	● ● ● ● ● ● ● ●
Asphalt	-	● ● ● ● ● ● ● ●	● ● ● ● ● ● ● ●
ASTM 1 OIL	-	● ● ● ● ● ● ● ●	● ● ● ● ● ● ● ●
ASTM 2 OIL	-	● ● ● ● ● ● ● ●	● ● ● ● ● ● ● ●
ASTM 3 OIL	-	● ● ● ● ● ● ● ●	● ● ● ● ● ● ● ●
Benzene	-	● ● ● ● ● ● ● ●	● ● ● ● ● ● ● ●
Sodium Bicarbonate	-	● ● ● ● ● ● ● ●	● ● ● ● ● ● ● ●
Carbon Dioxide	-	● ● ● ● ● ● ● ●	● ● ● ● ● ● ● ●
Butter	-	● ● ● ● ● ● ● ●	● ● ● ● ● ● ● ●
Butadiene	-	● ● ● ● ● ● ● ●	● ● ● ● ● ● ● ●
Liquid Butane	-	● ● ● ● ● ● ● ●	● ● ● ● ● ● ● ●
Fuel A (Isooctane 100%)	-	● ● ● ● ● ● ● ●	● ● ● ● ● ● ● ●
Fuel B (Isooct. 70% Toluene 30)	-	● ● ● ● ● ● ● ●	● ● ● ● ● ● ● ●
Fuel C (Isooct. 50% Toluene 50)	-	● ● ● ● ● ● ● ●	● ● ● ● ● ● ● ●
Fuel with Methanol or Ethanol	-	● ● ● ● ● ● ● ●	● ● ● ● ● ● ● ●
Kerosene	-	● ● ● ● ● ● ● ●	● ● ● ● ● ● ● ●
Cyclohexane	-	● ● ● ● ● ● ● ●	● ● ● ● ● ● ● ●
Chloroacetone	-	● ● ● ● ● ● ● ●	● ● ● ● ● ● ● ●
Chloroform	-	● ● ● ● ● ● ● ●	● ● ● ● ● ● ● ●
Chloroprene	-	● ● ● ● ● ● ● ●	● ● ● ● ● ● ● ●
Dry Chlorine	-	● ● ● ● ● ● ● ●	● ● ● ● ● ● ● ●
Wet Chlorine	-	● ● ● ● ● ● ● ●	● ● ● ● ● ● ● ●
Dibutyl Phthalate	-	● ● ● ● ● ● ● ●	● ● ● ● ● ● ● ●
Diethylene Glycol	-	● ● ● ● ● ● ● ●	● ● ● ● ● ● ● ●
Diethyl Sebacate	-	● ● ● ● ● ● ● ●	● ● ● ● ● ● ● ●
Dinitrotoluene	-	● ● ● ● ● ● ● ●	● ● ● ● ● ● ● ●
Diocetyl Phthalate	-	● ● ● ● ● ● ● ●	● ● ● ● ● ● ● ●
Diocetyl Sebacate	-	● ● ● ● ● ● ● ●	● ● ● ● ● ● ● ●
Epichlorohydrin	-	● ● ● ● ● ● ● ●	● ● ● ● ● ● ● ●
Hexane	-	● ● ● ● ● ● ● ●	● ● ● ● ● ● ● ●
Ethanol	-	● ● ● ● ● ● ● ●	● ● ● ● ● ● ● ●
Fluorobenzene	-	● ● ● ● ● ● ● ●	● ● ● ● ● ● ● ●
Liquid Fluorine	-	● ● ● ● ● ● ● ●	● ● ● ● ● ● ● ●
Formaldehyde	40	● ● ● ● ● ● ● ●	● ● ● ● ● ● ● ●
Formaldehyde	40	● ● ● ● ● ● ● ●	● ● ● ● ● ● ● ●
Freon 11	-	● ● ● ● ● ● ● ●	● ● ● ● ● ● ● ●
Freon 12	-	● ● ● ● ● ● ● ●	● ● ● ● ● ● ● ●
Freon 21	-	● ● ● ● ● ● ● ●	● ● ● ● ● ● ● ●
Freon 22	-	● ● ● ● ● ● ● ●	● ● ● ● ● ● ● ●
Freon 113	-	● ● ● ● ● ● ● ●	● ● ● ● ● ● ● ●
Freon 114	-	● ● ● ● ● ● ● ●	● ● ● ● ● ● ● ●
Glycerine	-	● ● ● ● ● ● ● ●	● ● ● ● ● ● ● ●
Silicone Grease	-	● ● ● ● ● ● ● ●	● ● ● ● ● ● ● ●
Hydrogen	-	● ● ● ● ● ● ● ●	● ● ● ● ● ● ● ●
Calcium Hydroxide	-	● ● ● ● ● ● ● ●	● ● ● ● ● ● ● ●
Sodium Hypochlorite	10	● ● ● ● ● ● ● ●	● ● ● ● ● ● ● ●
Milk	-	● ● ● ● ● ● ● ●	● ● ● ● ● ● ● ●
Mercury	-	● ● ● ● ● ● ● ●	● ● ● ● ● ● ● ●
Methanol	-	● ● ● ● ● ● ● ●	● ● ● ● ● ● ● ●
Methyl Ethyl Ketone	-	● ● ● ● ● ● ● ●	● ● ● ● ● ● ● ●
Naphtha	-	● ● ● ● ● ● ● ●	● ● ● ● ● ● ● ●
Nitrobenzene	-	● ● ● ● ● ● ● ●	● ● ● ● ● ● ● ●
Nitroethane	-	● ● ● ● ● ● ● ●	● ● ● ● ● ● ● ●
Nitromethane	-	● ● ● ● ● ● ● ●	● ● ● ● ● ● ● ●
Nitropropane	-	● ● ● ● ● ● ● ●	● ● ● ● ● ● ● ●
Animal Oil (Whale-Seal)	-	● ● ● ● ● ● ● ●	● ● ● ● ● ● ● ●
Grain Oil	-	● ● ● ● ● ● ● ●	● ● ● ● ● ● ● ●
Coconut Oil	-	● ● ● ● ● ● ● ●	● ● ● ● ● ● ● ●
Cod-Liver Oil	-	● ● ● ● ● ● ● ●	● ● ● ● ● ● ● ●
Olive Oil	-	● ● ● ● ● ● ● ●	● ● ● ● ● ● ● ●
Cottonseed Oil	-	● ● ● ● ● ● ● ●	● ● ● ● ● ● ● ●
Silicon Oil	-	● ● ● ● ● ● ● ●	● ● ● ● ● ● ● ●
Castor Oil	-	● ● ● ● ● ● ● ●	● ● ● ● ● ● ● ●
Oxygen	-	● ● ● ● ● ● ● ●	● ● ● ● ● ● ● ●
Ozone	-	● ● ● ● ● ● ● ●	● ● ● ● ● ● ● ●
Perchloroethylene	-	● ● ● ● ● ● ● ●	● ● ● ● ● ● ● ●
Potassium Permanganate	25	● ● ● ● ● ● ● ●	● ● ● ● ● ● ● ●
Tetraethyl Lead	-	● ● ● ● ● ● ● ●	● ● ● ● ● ● ● ●
Propane	-	● ● ● ● ● ● ● ●	● ● ● ● ● ● ● ●
Soda (Sodium Hydroxide)	10	● ● ● ● ● ● ● ●	● ● ● ● ● ● ● ●
Styrene	-	● ● ● ● ● ● ● ●	● ● ● ● ● ● ● ●
Toluene	-	● ● ● ● ● ● ● ●	● ● ● ● ● ● ● ●
Trichloroethylene	-	● ● ● ● ● ● ● ●	● ● ● ● ● ● ● ●
Sulfur	-	● ● ● ● ● ● ● ●	● ● ● ● ● ● ● ●

The data shown in the table are approximate



Table of mechanical features of elastomers

ELASTOMERS		NR	SBR	EPDM	NBR	CR	CSM	VMQ	FKM	
Specific weight		0.93	0.95	0.86	0.97	1.25	1.2	1.2	1.82	
Hardness	(Shore A)	25:95	35:95	40:85	30:90	25:90	40:90	30:80	50:90	
Tensile strength	(M Pa)	14:30	7:28	6:18	7:25	7:24	12:24	4:9	5:17	
Ultimate elongation	(%)	150:850	125:850	150:500	150:750	100:800	150:500	400:600	125:300	
Resilience	(%)	30:65	25:55	35:55	10:50	20:50	5:20	40:55	5:10	
Extreme operating temperatures		(°C)	-45:85	-40:90	-40:155	-40:110	-40:100	-15:120	-50:225	-20:250
Abrasion resistance		●	●●	●	●	●●	●●	●	●●	
Gas impermeability		●	●●	●	●●	●	●	●	●	

Class	Behaviour
●	recommended
●	satisfactory
●	unsatisfactory
●	not recommended

NR = NATURAL RUBBER

SBR = STYRENE-BUTADIENE RUBBER

EPDM = ETHYLENE-PROPYLENE THERMOPOLYMER

NBR = NITRILE RUBBER

CR = POLYCHLOROPRENE

CSM = CHLOROSULPHONATED POLYETHYLENE

VMQ = SILICONE RUBBER

FKM = FLUOROCARBON RUBBER (VITON®)

VITON® is a registered trademark of Dupont Dow Elastomers L.L.C.

Specifications of **TEFLON®** (Virgin PTFE)

Properties	U.m.	Values (from-to)
Specific weight	-	2.14 - 2.20
Ultimate strength	N/mm ²	20 - 35
Ultimate elongation	%	210 - 400
Compressive strength 1% deformat.	N/mm ²	4.00 - 4.50
Flexural strength 0.7 N/mm ²	N/mm ²	no breakage
Shock resistance 57°C	J/cm	1,1
Shock resistance 23°C	J/cm	1,6
Shock resistance 77°C	J/cm	3,3
Hardness	(shoreD)	50 - 60
Static friction coefficient	-	0,09
Dynamic friction coefficient	-	0,05
PTFE - oil-lubricated steel	-	0,02 - 0,06
Coefficient of expansion from 25 to 100°C	°C ⁻¹	16 x 10 ⁻⁵
Thermal conductivity	W/mK	0,2
Distortion temperatures 0.46 N/mm ²	°C	130 - 140
Distortion temperatures 1.85 N/mm ²	°C	50 - 60
Water absorption	%	<0,01
Inflammability ATB	sec	<5,00
Inflammability AEB	mm	<5,00
Operating temperature	°C	-200 +260

The data shown in the table are approximate

TEFLON® is a registered trademark of E.I. Dupont De Nemours & Co.

ISO METRIC M		
Thread Diameter	Drill Hole Diameter	
mm	mm	
M 1 x 0,25	0,75	
M 1,1 x 0,25	0,85	
M 1,2 x 0,25	0,95	
M 1,4 x 0,30	1,1	
M 1,6 x 0,35	1,25	
M 1,8 x 0,35	1,45	
M 2 x 0,4	1,6	
M 2,2 x 0,45	1,75	
M 2,5 x 0,45	2,05	
M 3 x 0,5	2,5	
M 3,5 x 0,6	2,9	
M 4 x 0,7	3,3	
M 4,5 x 0,75	3,7	
M 5 x 0,8	4,2	
M 6 x 1	5	
M 7 x 1	6	
M 8 x 1,25	6,8	
M 9 x 1,25	7,8	
M 10 x 1,5	8,5	
M 11 x 1,5	9,5	
M 12 x 1,75	10,2	
M 14 x 2	12	
M 16 x 2	14	
M 18 x 2,5	15,5	
M 20 x 2,5	17,5	
M 22 x 2,5	19,5	
M 24 x 3	21	
M 27 x 3	24	
M 30 x 3,5	26,5	
M 33 x 3,5	29,5	
M 36 x 4	32	
M 39 x 4	35	
M 42 x 4,5	37,5	
M 45 x 4,5	40,5	
M 48 x 5	43	
M 52 x 5	47	
M 56 x 5,5	50,5	

ISO METRIC FINE MF					
Thread Diameter	Drill Hole Diameter		Thread Diameter	Drill Hole Diameter	
mm	mm		mm	mm	
M 1 x 0,2	0,75		M 24 x 2	22	
M 1,1 x 0,2	0,9		M 25 x 1	24	
M 1,2 x 0,2	1		M 25 x 1,5	23,5	
M 1,4 x 0,2	1,2		M 25 x 2	23	
M 1,4 x 0,25	1,15		M 26 x 1,5	24,5	
M 1,6 x 0,2	1,4		M 27 x 1	26	
M 1,8 x 0,2	1,6		M 27 x 1,5	25,5	
M 2 x 0,25	1,75		M 27 x 2	25	
M 2,2 x 0,25	1,95		M 28 x 1	27	
M 2,5 x 0,35	2,15		M 28 x 1,5	26,5	
M 3 x 0,35	2,65		M 28 x 2	26	
M 3,5 x 0,35	3,15		M 30 x 1	29	
M 4 x 0,35	3,65		M 30 x 1,5	28,5	
M 4 x 0,5	3,5		M 30 x 2	28	
M 4,5 x 0,5	4		M 30 x 3	27	
M 5 x 0,5	4,5		M 32 x 1,5	30,5	
M 5,5 x 0,5	5		M 32 x 2	30	
M 6 x 0,75	5,2		M 33 x 1,5	31,5	
M 7 x 0,75	6,2		M 33 x 2	31	
M 8 x 1	7		M 33 x 3	30	
M 8 x 0,75	7,2		M 35 x 1,5	33,5	
M 9 x 1	8		M 36 x 1,5	34,5	
M 9 x 0,75	8,2		M 36 x 2	34	
M 10 x 1	9		M 36 x 3	33	
M 10 x 0,75	9,2		M 38 x 1,5	36,5	
M 10 x 1,25	8,8		M 39 x 1,5	37,5	
M 11 x 1	10		M 39 x 2	37	
M 11 x 0,75	10,2		M 39 x 3	36	
M 12 x 1	11		M 40 x 1,5	38,5	
M 12 x 1,25	10,8		M 40 x 2	38	
M 12 x 1,5	10,5		M 40 x 3	37	
M 14 x 1	13		M 42 x 1,5	40,5	
M 14 x 1,25	12,8		M 42 x 2	40	
M 14 x 1,5	12,5		M 42 x 3	39	
M 15 x 1	14		M 42 x 4	38	
M 15 x 1,5	13,5		M 45 x 1,5	43,5	
M 16 x 1	15		M 45 x 2	43	
M 16 x 1,5	14,5		M 45 x 3	42	
M 17 x 1	16		M 45 x 4	41	
M 17 x 1,5	15,5		M 48 x 1,5	46,5	
M 18 x 1	17		M 48 x 2	46	
M 18 x 1,5	16,5		M 48 x 3	45	
M 18 x 2	16		M 48 x 4	44	
M 20 x 1	19		M 50 x 1,5	48,5	
M 20 x 1,5	18,5		M 50 x 2	48	
M 20 x 2	18		M 50 x 3	47	
M 22 x 1	21		M 52 x 1,5	50,5	
M 22 x 1,5	20,5		M 52 x 2	50	
M 22 x 2	20		M 52 x 3	49	
M 24 x 1	23		M 52 x 4	48	
M 24 x 1,5	22,5				

WHITWORTH W BSW	
Nominal Thread Diameter	Drill Hole Diameter
Inches	mm
1/8 - 40	2,55
5/32 - 32	3,2
3/16 - 24	3,7
1/4 - 20	5,1
5/16 - 18	6,5
3/8 - 16	7,9
7/16 - 14	9,2
1/2 - 12	10,5
9/16 - 12	12
5/8 - 11	13,5
3/4 - 10	16,25
7/8 - 9	19,25
1 - 8	21,75
1 1/8 - 7	24,75
1 1/4 - 7	27,75
1 3/8 - 6	30,5
1 1/2 - 6	33,5
1 5/8 - 5	35,5
1 3/4 - 5	39
2 - 4 1/2	44,5
2 1/4 - 4	50
2 1/2 - 4	56,5
2 3/4 - 3 1/2	62
3 - 3 1/2	62

WHITWORTH GAS BSP	
Nominal Thread Diameter	Drill Hole Diameter
Inches	mm
G 1/8 - 28	8,8
G 1/4 - 19	11,8
G 3/8 - 19	15,25
G 1/2 - 14	19
G 5/8 - 14	21
G 3/4 - 14	24,5
G 7/8 - 14	28,25
G 1 - 11	30,75
G 1 1/8 - 11	35,3
G 1 1/4 - 11	39,25
G 1 3/8 - 11	41,9
G 1 1/2 - 11	45,25
G 1 3/4 - 11	51,3
G 2 - 11	57
G 2 1/4 - 11	63,1
G 2 1/2 - 11	72,6
G 2 3/4 - 11	79,1
G 3 - 11	85,5
G 3 1/4 - 11	91,5
G 3 1/2 - 11	97,7
G 3 3/4 - 11	104
G 4 - 11	110,5

TAPERED GAS BSPT	
Nominal Thread Diameter	Drill Hole Diameter
Inches	mm
1/8 - 28	8,4
1/4 - 19	11,2
3/8 - 19	14,75
1/2 - 14	18,25
3/4 14	23,75
1 - 11	30
1 1/4 - 11	38,5
1 1/2 - 11	44,5
2 - 11	56
2 1/2 - 11	71,5

AMERICAN NPT	
Nominal Thread Diameter	Drill Hole Diameter
Inches	mm
1/6 - 27	6,25
1/8 - 27	8,5
1/4 - 18	11
3/8 - 18	14,5
1/2 14	18
3/4 - 14	23
1 - 11 1/2	29
1 1/4 - 11 1/2	38
1 1/2 - 11 1/2	44
2 - 11 1/2	56
2 1/2 - 8	67

UNIFIED COARSE THREAD UNC	
Nominal Thread Diameter	Drill Hole Diameter
Inches	mm
Nr. 1 - 64	1,5
Nr. 2 - 56	1,8
Nr. 3 - 48	2,02
Nr. 4 - 40	2,25
Nr. 5 - 40	2,6
Nr. 6 - 32	2,75
Nr. 8 - 32	3,4
Nr. 10 - 24	3,8
Nr. 12 - 24	4,5
1/4 - 20	5,1
5/46 - 18	6,5
3/8 - 16	8
7/16 - 14	9,4
1/2 - 13	10,75
9/16 - 12	12,2
5/8 - 11	13,6
3/4 - 10	16,5
7/8 - 9	19,5
1 - 8	22,25
1 1/8 - 7	25
1 1/4 - 7	28,25
1 3/8 - 6	30,75
1 1/2 - 6	34
1 3/4 - 5	39,5
2 - 4 1/2	45

UNIFIED COARSE THREAD UNF	
Nominal Thread Diameter	Drill Hole Diameter
Inches	mm
Nr. 0 - 80	1,25
Nr. 1 - 72	1,55
Nr. 2 - 64	1,85
Nr. 3 - 56	2,1
Nr. 4 - 48	2,35
Nr. 5 - 44	2,65
Nr. 6 - 40	2,9
Nr. 8 - 36	3,5
Nr. 10 - 32	4,1
Nr. 12 - 28	4,6
1/4 - 28	5,5
5/16 - 24	6,9
3/8 - 24	8,5
7/16 - 20	9,9
1/2 - 20	11,5
9/16 - 18	12,9
5/8 - 18	14,5
3/4 - 16	17,5
7/8 - 14	20,5
1 - 12	23,25
1 1/8 - 12	26,5
1 1/4 - 12	29,75
1 3/8 - 12	33
1 1/2 - 12	36

AMERICAN NPTF	
Nominal Thread Diameter	Drill Hole Diameter
Inches	mm
1/6 - 27	6,15
1/8 - 27	8,4
1/4 - 18	10,9
3/8 - 18	14,25
1/2 14	17,75
3/4 - 14	23
1 - 11 1/2	29
1 1/4 - 11 1/2	37,75
1 1/2 - 11 1/2	43,75
2 - 11 1/2	55,75
2 1/2 - 8	66,5

DRILL HOLES FOR ROLL FORM TAPS

ISO METRIC M		
Thread Diameter	Drill Hole Diameter	
mm	mm	
M 1 x 0.25	0,9	
M 1,2 x 0.25	1,1	
M 1,4 x 0,3	1,25	
M 1,6 x 0.35	1,45	
M 1,8 x 0.35	1,65	
M 2 x 0.4	1,8	
M 2,5 x 0.45	2,3	
M 3 x 0,5	2,8	
M 3,5 x 0,6	3,2	
M 4 x 0,7	3,7	
M 5 x 0,8	4,6	
M 6 x 1	5,5	
M 7 x 1	6,5	
M 8 x 1.25	7,4	
M 10 x 1,5	9,3	
M 12 x 1.75	11,2	
M 14 x 2	13	
M 16 x 2	15	

UNIFIED COARSE THREAD UNC		
Nominal Thread Diameter	Drill Hole Diameter	
Inches	mm	
Nr. 1 - 64	1,7	
Nr. 2 - 56	2	
Nr. 3 - 48	2,3	
Nr. 4 - 40	2,6	
Nr. 5 - 40	2,9	
Nr. 6 - 32	3,2	
Nr. 8 - 32	3,8	
Nr. 10 - 24	4,4	
Nr. 12 - 24	5	
1/4 - 20	5,8	
5/16 - 18	7,3	
3/8 - 16	8,8	
7/16 - 14	10,3	
1/2 - 13	11,9	

ISO METRIC FINE MF		
Thread Diameter	Drill Hole Diameter	
mm	mm	
M 4 x 0.5	3,5	
M 5 x 0,5	4,5	
M 6 x 0.75	5,2	
M 8 x 0.75	7,2	
M 8 x 1	7,2	
M 10 x 1	9	
M 10 x 1.25	8,8	
M 12 x 1	11	
M 12 x 1.25	10,8	
M 12 x 1.5	10,5	
M 14 x 1	13	
M 14 x 1.25	12,8	
M 14 x 1,5	12,5	
M 16 x 1	15	
M 16 x 1,5	14,5	

UNIFIED COARSE THREAD UNF		
Nominal Thread Diameter	Drill Hole Diameter	
Inches	mm	
Nr. 1 - 72	1,7	
Nr. 2 - 64	2	
Nr. 3 - 56	2,3	
Nr. 4 - 48	2,6	
Nr. 5 - 44	2,9	
Nr. 6 - 40	3,2	
Nr. 8 - 36	3,9	
Nr. 10 - 32	4,5	
Nr. 12 - 28	5,1	
1/4 - 28	6	
5/16 - 24	7,5	
3/8 - 24	9,1	
7/16 - 20	10,6	
1/2 - 20	12,1	

VIVOIL OLEODINAMICA VIVOLO

s.r.l. Società a Socio Unico

Via Leone Ginzburg 2-4 - 40054 Cento di Budrio (BO) - ITALY - TEL. +39 - 051.803689 Fax +39 - 051.800061

Partita Iva e cod. Fiscale 03542620376 C.C.I.A.A. 299009 - Iscr. Trib.: BO 43434

WEB: www.vivoil.com E-mail vivoil@vivoil.com

®

